



















**CABLE
CARRIERS**
for □-Tracks



CONTENTS

General Information		3
Questionnaire		4
S 1 Track & Accessories		5 – 9
S 1 Cable carriers & Accessories – Polyamid type –		10
S 1 Cable carriers & Accessories – Polyamid swivel type –		11
S 1 Cable carriers & Accessories – Steel type –		12 – 14
S 1 Cable carriers & Accessories – Steel type –		15, 16
S 1 Cable carriers & Accessories – Steel type for round cables & hoses –		17
S 1 Control carriers & Accessories		18, 19
S 2 Track & Accessories		20 – 23
S 2 Cable carriers & Accessories – Polyamid type –		24
S 2 Cable carriers – Steel type –		25, 26
S 2 Cable carriers & Accessories – Steel type –		27
S 2 Cable carriers & Accessories – Steel swivel type –		28
S 2 Cable carriers & Accessories – Steel type for round cables & hoses –		29
S 2 Control carriers & Accessories		30, 31
S 2 Control carriers with motorized lifting device for pushbuttons		32
S 2 Control carriers installation information		33
S 3 Track & Accessories		34
S 3 Cable carriers & Accessories – Steel type –		35
K 1 Track & Accessories		36, 37
K 1 Cable carriers & Accessories		38
K 1 Accessories & Control carriers		39
K 1 Cable carriers & Accessories		40
Chains and ropes for cable tension relief		41
Typical Applications and How to Order		42 – 44
Installation Information		45
System Layout		46
Graph to find Support Spacing for Tracks in relation to area loads and permissible loads per meter		47
How to determine Number and Depth of Cable Loops, Storage Distance, Cable Length, Number of Carriers		48
Graphs to find Number of Cable Loops considering 10, 15 and 20 % cable safety length		49 – 51

Catalog No. 8a: Cable Carriers on □ -Tracks

Catalog No. 8bF: Cable Carriers for flatform cable on I-Beams

Catalog No. 8bR: Cable Carriers for round cable on I-Beams

Catalog No. 8c: Cable Carriers on ◇ -Tracks

Catalog No. 8L: Conductor cables & Fittings



General

VAHLE Festoon Systems support conductor cables (flat or round) and hoses (hydraulic and pneumatic applications) for delivering power and control to mobile equipment in a safe, efficient and maintenance free method.

The cable carriers are well guided inside their □-tracks and protected against humidity, dust and icing.

All box-tracks can be bent in accordance to the system layout, considering the minimum bending radii and the permissible cable loops.

VAHLE cable carriers contained in this catalog comply with the VDE and most international regulations.

The use of flatform cable is highly recommended due to better bending properties compared to round cable. The minimum bending radius permissible for round cable is 5 times the cable diameter – for flat cable it is 5 times the thickness of the cable. This formula allows considerably smaller bend radii for flat cable, minimizing the required Festoon System storage distance which is normally within the length of equipment (e. g. hoist trolley – see page 4).

VAHLE cable carriers not only deliver power and control to mobile equipment which has reciprocal motion but also support large quantities of data cables including optic fibres travelling independently from the mobile machinery. The relevant control carriers with and without push button lifting are also shown in this catalog.

Layout

Selection of the proper carriers and components must be based on the chosen cable (see our catalog 8L – Conductor Cables and Fittings) or hose data that meets your electrical and mechanical requirements.

Refer to the pages 46 – 48 or send us the completed Questionnaire on page 4. Prints or sketches for system layouts including curves would be appreciated whenever obtainable.

For extra heavy duty or arduous applications it is recommended to check in our catalogs 8b F & R for our Innovative Festoon Technology on I-Beam tracks or 8c for Festoon Systems on diamond ◊ shaped tracks.

In any case we welcome your inquiries and guarantee our prompt quotations.

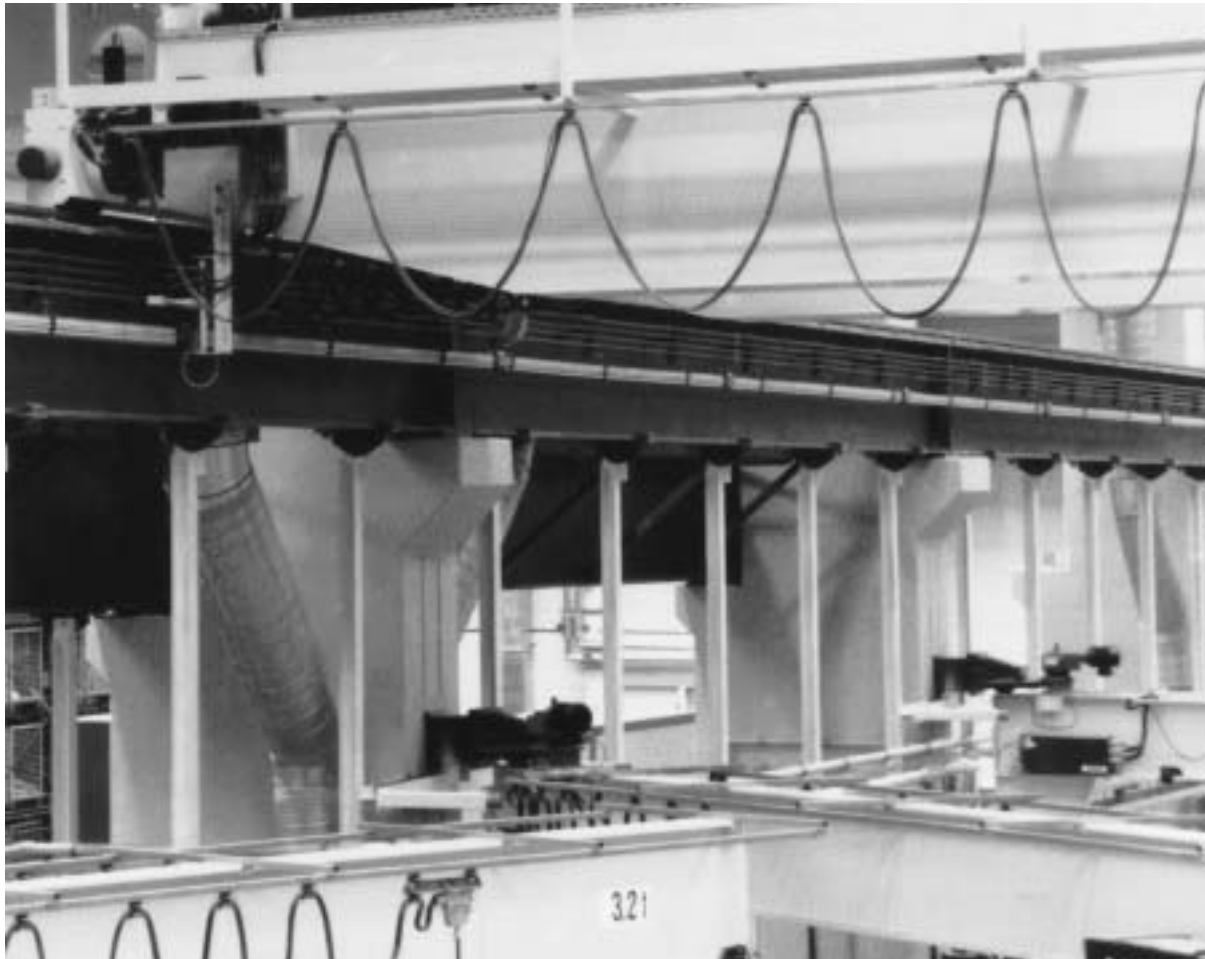



QUESTIONNAIRE

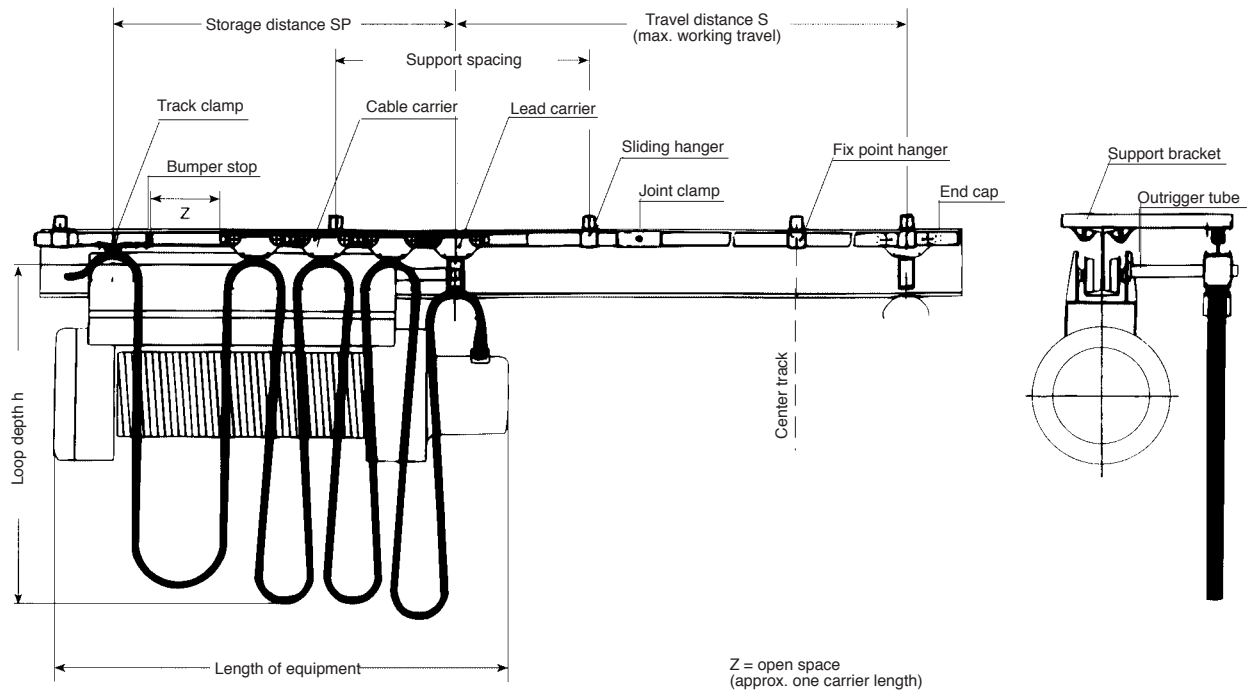

Name and Address of Customer _____

Ref.: _____

1. Type of Application: _____

2. Outdoors Indoors _____

3. Temperature range _____ °C min. _____ °C max. _____

4. Is round or flatform cable envisaged? _____

5. How much space is available for storage? SP = _____ m

6. Is it possible to extend the track for the festoon cable system in case the length of equipment is insufficient for storage space?

Yes, by _____ m; no, not possible.

7. Special operating conditions: _____

8. Length of equipment: _____ m

9. Travel distance: S = _____ m

10. Travel speed: V = _____ m/min

11. Acceleration: a = _____ m/sec²

12. Max loop depth: h = _____ m

13. Hookup cable length required at Track clamp side: L_E = _____ m

14. Hookup cable length required at Lead carrier side: L_M = _____ m

15. Required cables:

No. of cables	No. & Size of conductors	cable OD Ø/mm	width x thickness of flatform cables



S 1 TRACK AND ACCESSORIES

acid proof



Track

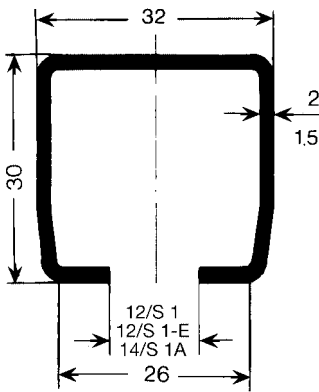

Type	S1	S1A	S1-E
Order-No. -in 6 m sections	312 946	312 966	312 956
Order-No. -in 4 m sections	312 944	312 964	312 954
Order-No. -surcharge for curves	310 470	310 470	312 472
for Carrier type	WS 1, WST 1		WST 1-E
Thickness	2 mm	1,5 mm	2 mm
Material	steel, galvanized		
Supply lengths	6 m and 4 m		
Standard support spacing	2 m; in curves 1 m		
Moment of inertia Jx	2,42 cm ⁴	1,9 cm ⁴	2,42 cm ⁴
Section modulus Wx	1,45 cm ³	1,1 cm ³	1,45 cm ³
Weight	1,550 kg/m	1,190 kg/m	1,550 kg/m

Horizontal curves w/min. radius of 1 m are ready available. Consult factory for specials.
Support spacing for tracks see diagram on page 47.

Hanger underhung

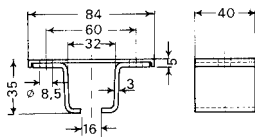

Type	Fixpoint hanger FAS 1
Order-No.	310 500
Material	steel, galvanized
Weight	0,160 kg

For up to 30 m runs only.
 1 pair of bolts M 8x25, Order-No. 310 510 to be ordered separately for each hanger or provided by customer.

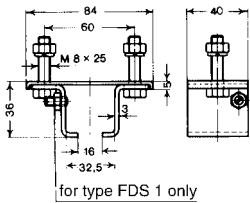

Type	Sliding hanger ADS 1 *	Fixpoint hanger FDS 1	Sliding hanger ADS 1-E *	Fixpoint hanger FDS 1-E
Order-No.	310 370	310 430	312 393	312 394
Material	steel, galvanized		V 4 A, stainless steel	
Weight	0,200 kg	0,210 kg	0,200 kg	0,210 kg

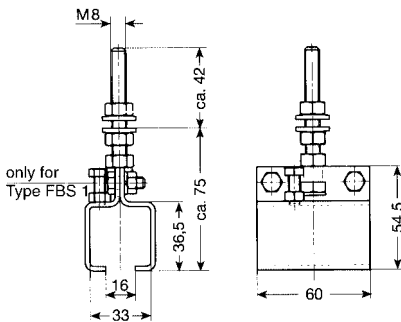

Type	Sliding hanger ABS 1 *	Fixpoint hanger FBS 1
Order-No.	312 863	312 864
Material	steel, galvanized	
Weight	0,226 kg	0,234 kg

Hanger underhung for HK support

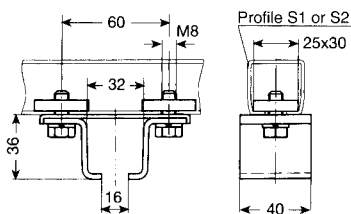

Type	Fixpoint hanger FAKS 1
Order-No.	310 590
Material	steel, galvanized
Weight	0,260 kg

For up to 30 m runs only.

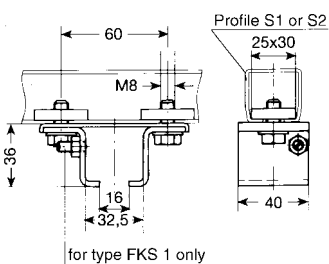

Type	Sliding hanger AKS 1 *	Fixpoint hanger FKS 1	Sliding hanger AKS 1-E *	Fixpoint hanger FKS 1-E
Order-No.	310 380	310 450	312 457	312 458
Material	steel, galvanized		V 4 A, stainless steel	
Weight	0,260 kg	0,270 kg	0,260 kg	0,270 kg

* For systems with control-carriers use fixpoint hangers only.



S 1 ACCESSORIES

acid proof



Double Hanger for S 1 Track

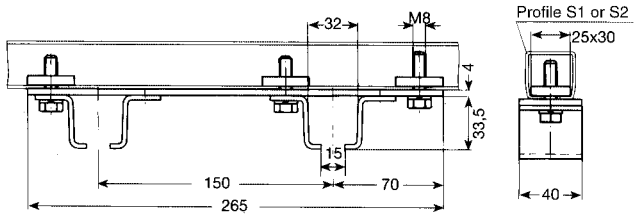

Type	DFAK-S 1
Order-No.	312 599
Material	steel, galvanized
Weight	0,660 kg

Hanger lateral

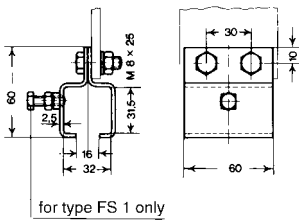

Type	Sliding hanger AS 1*	Fixpoint hanger FS 1
Order-No.	310 030	310 040
Material	steel, galvan.	steel, galvan.
Weight	0,220 kg	0,230 kg

Hanger lateral

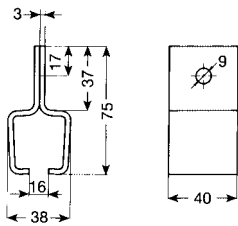

Type	Fixpoint hanger FO-S 1
Order-No.	312 809
Material	steel, galvanized
Weight	0,160 kg

For up to 30 m runs only.

Hanger for tube

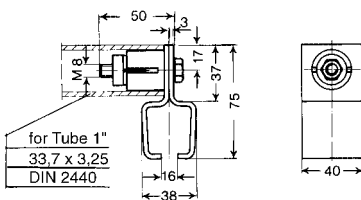

Type	Fixpoint hanger FR 1-S 1
Order-No.	310 991
Material	steel, dowel: polyamid
Weight	0,215 kg

Joint Clamp

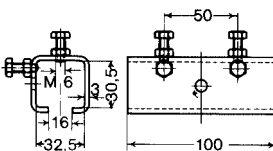

Type	VS 1	VS 1-E
Order-No.	310 050	312 392
Material	steel, galvanized	V 4 A, stainless steel
Weight	0,340 kg	0,340 kg

End Cap

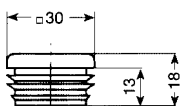

Type		K 30
Order-No.		360 023
Material		polyethylene
Weight		0,008 kg



S 1 ACCESSORIES

acid
proof



Bumper stop

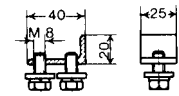

PS 1 (-E)

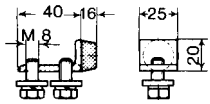

PS 1 G

Type	PS 1	PS 1 G	PS 1-E
Order-No.	310 300	310 360	312 395
Material	steel, galvanized	steel, galvanized	V 4 A, stainless steel
Weight	0,080 kg	0,100 kg	0,080 kg

Bumper stop

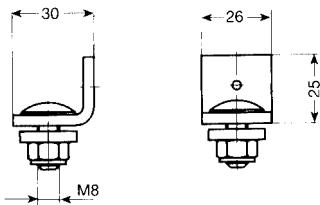

Type	PS 1-1
Order-No.	312 605
Material	steel, galvanized
Weight	0,063 kg

Flat Nut w/bolt and washer

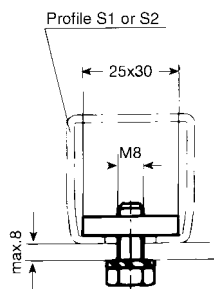

Type	M 8 x 20
Order-No.	312 600
Material	steel, galvanized
Weight	0,044 kg

Clamps for round cables and hoses

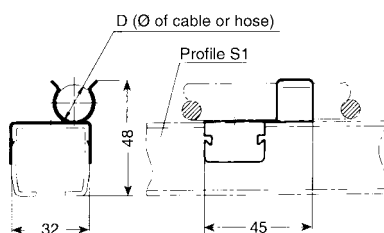

Type	Material	Weight kg	Dim. D mm	Order-No.
HS 1-D 9	stainless	0,010	8 – 10	312 667
HS 1-D 16	steel	0,011	15 – 20	312 666



S 1 ACCESSORIES

acid proof



Standard Brackets

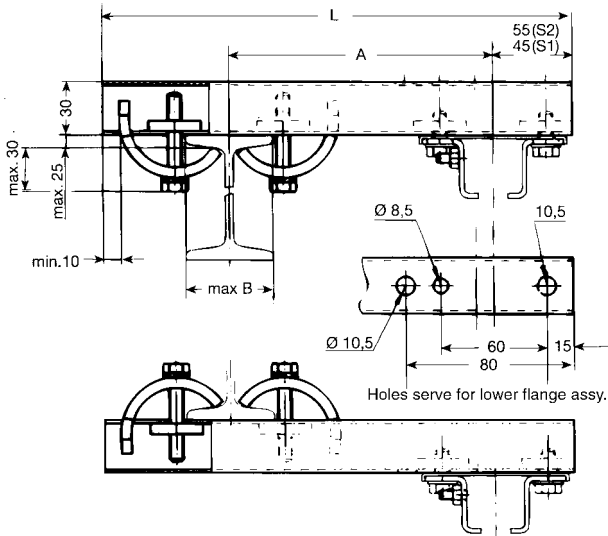

Choose dim. A per local requirements and make sure that hoist wheels have enough clearance.

Select next larger size bracket when your I-Beam dim. B is more than 210 mm and refer to page 9 for heavy duty brackets.

Type	Material	Weight kg	A (adjustable) mm	L mm	max. B mm	Order-No.	Type	Mat.	Order-No.
HK 200	steel galvanized	0,980	200	400	210	310 220	HK 200-E	stainl. steel V 4 A	312 510
HK 300		1,130	300	500	210	310 230	HK 300-E		312 511
HK 400		1,290	400	600	210	310 240	HK 400-E		312 512
HK 500		1,430	500	700	210	310 250	HK 500-E		312 513

Hangers AKS 1, FKS 1 and FAKS 1 to be ordered separately.

Bracket Bars for HK

Type	Material	Weight kg	L mm	Order-No.	Type	Mat.	Order-No.
S 1-400	steel galvanized	0,620	400	310 600	S 1E-400	stainl. steel V 4 A	312 515
S 1-500		0,780	500	310 610	S 1E-500		312 516
S 1-600		0,930	600	310 620	S 1E-600		312 517
S 1-700		1,090	700	310 630	S 1E-700		312 518

Claws for HK

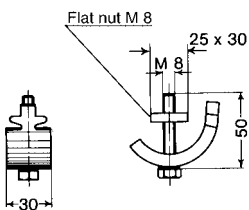

Type	SP	SP-E
Order-No.	310 390	312 514
Material	steel, galvanized	V 4 A, stainless steel
Weight	0,200 kg	0,200 kg

Flat nut M 8 separately available.
Order-No. 310 955

Flat nut M 8-E stainless separately available.
Order-No. 312 545

Support Attachment for HK

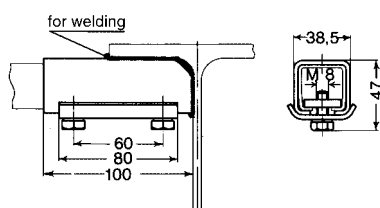

Type	AH 1
Order-No.	310 400
Material	steel, galvanized
Weight	0,460 kg

Bracket bar and hangers to be ordered separately.



S 1 ACCESSORIES

acid proof



General Assembly of Heavy Duty Bracket

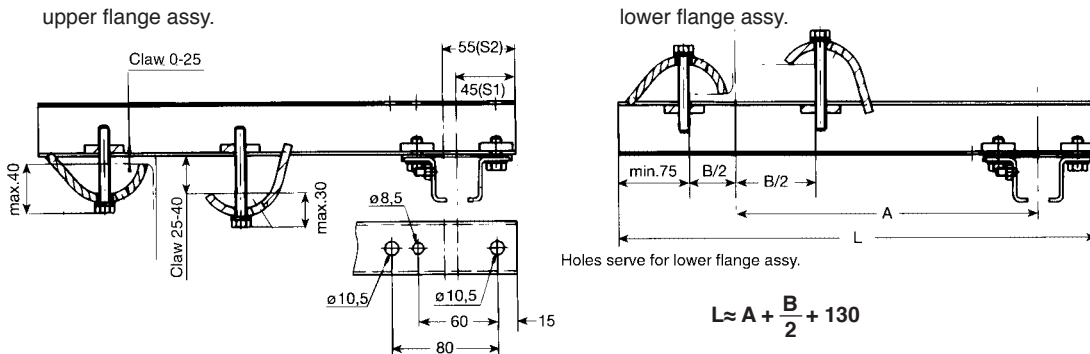

Bracket Bars for HK heavy duty

Type	Material	Weight kg	Dim. L mm	Order-No.	Type	Mat.	Order-No.
S 2- 400	steel galvanized	0,996	400	315 402	S 2E- 400	stainl. steel V 4 A	316 513
S 2- 500		1,245	500	315 403	S 2E- 500		316 514
S 2- 600		1,494	600	315 404	S 2E- 600		316 515
S 2- 700		1,743	700	315 405	S 2E- 700		316 516
S 2- 800		1,992	800	315 406	S 2E- 800		316 517
S 2- 900		2,241	900	315 407	S 2E- 900		316 518
S 2-1000		2,490	1000	315 408	S 2E-1000		316 519
S 2-1100		2,739	1100	315 409	S 2E-1100		316 520
S 2-1200		2,988	1200	315 410	S 2E-1200		316 521

Claws for HK heavy duty

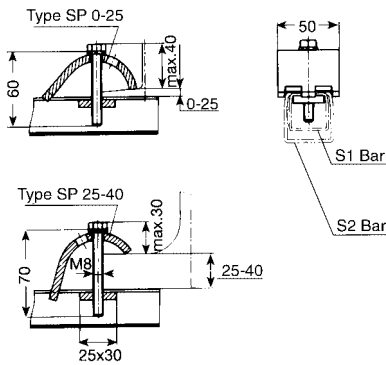

Type	SP 0-25	SP 0-25-E
Order-No.	312 643	316 690
Material	steel, galvanized	V 4 A (stainless steel)
Weight	0,286 kg	0,286 kg

Type	SP 25-40	SP 25-40-E
Order-No.	312 644	316 695
Material	steel, galvanized	V 4 A (stainless steel)
Weight	0,287 kg	0,287 kg

Support Attachment for HK heavy duty

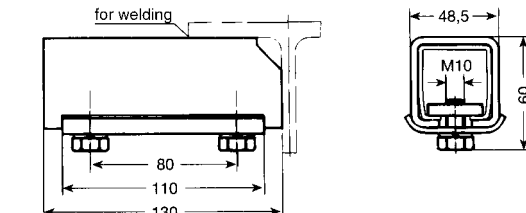

Type	AH 2
Order-No.	310 989
Material	steel, galvanized
Weight	0,940 kg

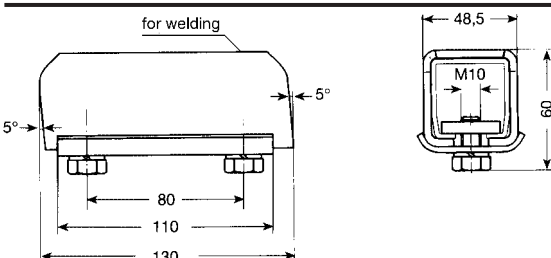

Type	AH 2-2
Order-No.	312 648
Material	steel, galvanized
Weight	0,854 kg



S 1 CABLE CARRIERS AND ACCESSORIES

- Polyamid type -



Engineering Data

Type	WS 1 F
Wheels	A) Polyamid rollers on bushed bearing; axle galvanized Material: polyamid, Travelling speed: ca. 50 m/min. B) Polyamid rollers on stainless bushed bearing Material: polyamid, Travelling speed: ca. 50 m/min. C) Polyamid rollers with ball bearing; inner race hardened, galvanized outer race Polyamid, Travelling speed: ca. 60 m/min. D) hardened and galvanized steel rollers with precision ball bearing, sealed against dust and splash water Temperature resistance: lub. grease of wheels: -30° C to +125° C Travelling speed: ca. 80 m/min.
Material	Carrier body: Polyamid Support saddle: Polyamid Hardware: galvanized Temperature resistance: - 30° C to +100° C
Max. cable load	max. 8 kg per Carrier with roller A max. 10 kg per Carrier with roller B + C max. 16 kg per Carrier with roller D
for corrosive sites	use system S 1-E or K1

Cable Carriers for flatrom cables

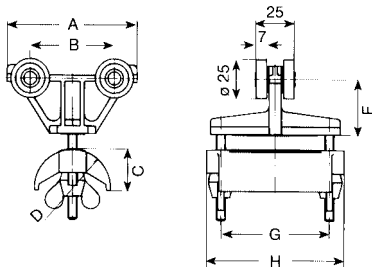

Type	wheels	max. thickness of individual cable mm	max. clamping capacity mm height x width	mm								Weight kg	Order No. *	with patented nut Order-No. **
				A	B	C	D	E	G	H				
WS 1 F/ 85 G	A	8	17x65	85	55	25	50	37	71	90	0,120	310 958	312 686	
WS 1 F/ 85 K	B										0,130	310 180	312 687	
WS 1 F/ 85 KL	C										0,130	310 320	312 688	
WS 1 F/ 85	D										0,190	310 070	312 689	
WS 1 F/125-50 G	A	8	37x65	125	95	40	50	37	71	90	0,150	312 759	312 760	
WS 1 F/125-50 K	B										0,160	312 761	312 762	
WS 1 F/125-50 KL	C										0,160	312 763	312 764	
WS 1 F/125-50	D										0,220	312 765	312 766	
WS 1 F/125-80 G	A	10	22x65	125	95	40	80	37	71	90	0,170	312 767	312 768	
WS 1 F/125-80 K	B										0,180	312 769	312 770	
WS 1 F/125-80 KL	C										0,180	312 771	312 772	
WS 1 F/125-80	D										0,240	312 773	312 774	

Lead Carriers for flatrom cables

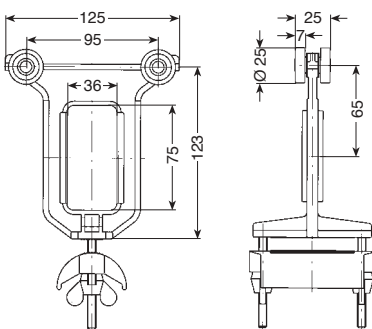

Type	wheels	for Carrier type	Weight kg	Order Nr. *	with patented nut Order-No. **
MS 1 F/125-50 G	A	WS 1 F/ 85 G, WS 1 F/125-50 G	0,140	313 281	313 285
MS 1 F/125-50 K	B	WS 1 F/ 85 (K, G), WS 1 F/125-50 (K, G)	0,144	313 280	313 284
MS 1 F/125-50 KL	C	WS 1 F/ 85 (KL, K, G), WS 1 F/125-50 (KL, K, G)	0,158	313 279	313 283
MS 1 F/125-50	D	WS 1 F/85 (all types) WS 1 F/125-50 (all types)	0,200	313 278	313 282
MS 1 F/125-80 G	A	WS 1 F/125-80 G	0,156	313 293	313 297
MS 1 F/125-80 K	B	WS 1 F/125-80 (K, G)	0,162	313 292	313 296
MS 1 F/125-80 KL	C	WS 1 F/125-80 (KL, K, G)	0,174	313 291	313 295
MS 1 F/125-80	D	WS 1 F/125-80 (all types)	0,216	313 290	313 294

Track Clamps for flatrom cables

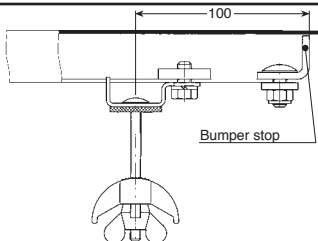

Type	for Carrier type	Weight kg	Order No. *	with patented nut Type	Order-No. **
ES 1 F/ 85	WS 1 F/ 85 (all types) WS 1 F/125-50 (all types)	0,220	313 303	EST 1-2 F/ 85-PM	313 304
ES 1 F/125-80	WS 1 F/125-80 (all types)	0,240	313 307	EST 1-2 F/125-PM	313 308

Bumper stop PS 1, PS 1-1, PS 1 G to be ordered separately.

Track Clamp with bumper for flatrom cables

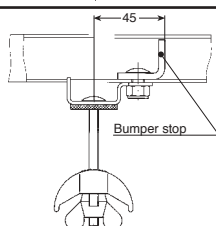

Type	for Carrier type	Weight kg	Order No. *	with patented nut Type	Order-No. **
EP S1 F/ 85	WS 1 F/ 85 (all types)	0,230	313 305	EPST 1-2 F/85-PM	313 306



S 1 CABLE CARRIERS AND ACCESSORIES

- Polyamid swivel type -



Engineering Data

Type	WS 1 R
Wheels	<p>A) Polyamid rollers on bushed bearing; axle galvanized Material: polyamid, Travelling speed: ca. 50 m/min.</p> <p>B) Polyamid rollers on stainless bushed bearing Material: polyamid, Travelling speed: ca. 50 m/min.</p> <p>C) Polyamid rollers with ball bearing; inner race hardened, galvanized outer race Polyamid, Travelling speed: ca. 60 m/min.</p> <p>D) hardened and galvanized steel rollers with precision ball bearing, sealed against dust and splash water Temperature resistance: lub. grease of wheels: -30° C to +125° C Travelling speed: ca. 80 m/min.</p>
Material	<p>Carrier body: Polyamid Support saddle: Polyamid Hardware: galvanized Temperature resistance: - 30° C to +100° C</p>
Max. cable load	<p>max. 8 kg per Carrier with roller A max. 10 kg per Carrier with roller B + C max. 16 kg per Carrier with roller D</p>
for corrosive sites	use system S 1-E or K1

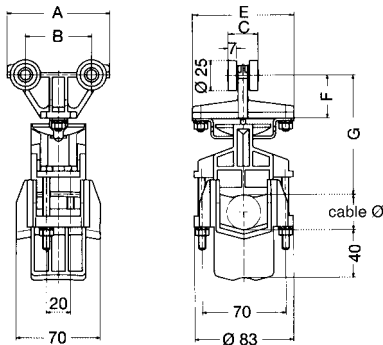

Cable Carriers for round cables and hoses

Type	Cable Ø	Wheels	A B C D E F G							Weight kg	Order-No.
			mm								
WS 1 R/85 G	5 mm to 38 mm	A	85	55	25	25	85	36	99	0,260	313 332
WS 1 R/85 K		B								0,270	312 486
WS 1 R/85 KL		C								0,280	312 487
WS 1 R/85		D								0,320	312 485

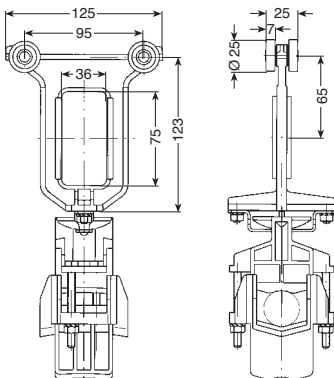

Lead Carriers for round cables and hoses

Type	for Carrier type	Weight kg	Order No.
MS 1 R/125 G	WS 1 R/85 G	0,284	313 289
MS 1 R/125 K	WS 1 R/85 (K, G)	0,288	313 288
MS 1 R/125 KL	WS 1 R/85 (KL, K, G)	0,302	313 287
MS 1 R/125	WS 1 R/85 (all types)	0,304	313 286

Track Clamp for round cables and hoses

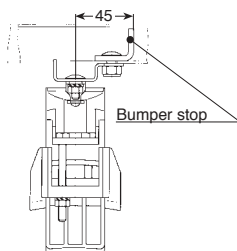

Type	for Carrier type	Weight kg	Order No.
EPST 1-2 R	WS 1 R (alle Typen)	0,346	313 322

Support Saddle for round cables and hoses for additional tiers

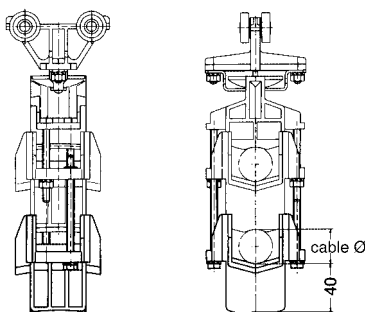

Type	for Carrier type	Weight kg	Order-No.
LAR	WS 1 R (all types)	0,110	312 500



S 1 CABLE CARRIERS AND ACCESSORIES - Steel type -



acid
proof

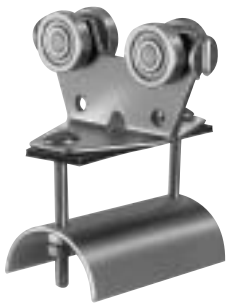

Support saddle
with hex. nut

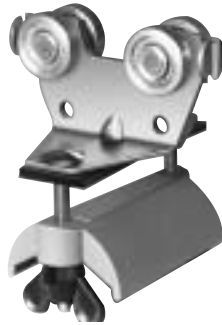

Support saddle
with patented nut

Engineering Data

Type	WST 1 F	WST 1 F-E	WST 1 F K-E
Wheels	ball bearings sealed against dust and splash water hardened, galvanized Temperature resistance Lub. grease of wheels: -30° C to +125° C Travelling speed: ca. 80 m/min.	sealed ball bearings stainless steel, V 4 A -30° C to +150° C ca. 80 m/min.	Polyamid rollers on bushed bearing ca. 50 m/min.
Material	Carrier body: steel, galvanized Support saddle: steel, galvanized D = 140 – aluminium Bumper: Neoprene Hardware: galvanized Temperature resistance: - 30° C to +100° C	V 4 A, stainless steel V 4 A, stainless steel Neoprene V 4 A, stainless steel - 30° C to +80° C	
Max. cable load	max. 22 kg per carrier	max. 12 kg per carrier	max. 8 kg je LW.
Depth of cable loop	in curves max. 0,3 x track radius, consider tension relief		not in curves
for corrosive sites	use system S 1-E or K 1		

Cable Carriers for flatrom cables

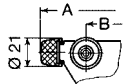

Bumper type

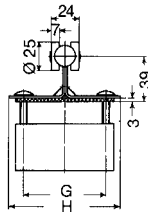
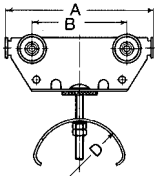

Type	max. thickn. of individual cable mm	max. clamping capacity in mm height x width	A	B	Ø D	G	H	Weight kg	Order-No.	with patented nut Order-No.**	Type	Order-No.	Type	Order-No.
			mm											
WST 1 F/ 85 *	8	17 x 65	85	48	50	85	85	0,360	312 000	312 789	WST 1 F/ 85 E *	312 381	WST 1 F/ 85 K-E *	313 218
WST 1 F/ 85 P		29 x 65	110					0,370	312 010	312 790	WST 1 F/ 85P-E	312 387	WST 1 F/ 85 KP-E	313 219
WST 1 F/125-50 *		37 x 65	125	80				97	0,460	312 533	312 791	WST 1 F/125-50-E *	312 519	WST 1 F/125-50K-E *
WST 1 F/125-50 P	50 x 65	150	0,470		312 534	312 792	WST 1 F/125-50P-E		312 520	WST 1 F/125-50KP-E	313 222			
WST 1 F/125 *	10	22 x 65	125	80	0,520	312 020	312 793		WST 1 F/125-E *	312 384	WST 1 F/125 K-E *	313 223		
WST 1 F/125 P		34 x 65	150	80	0,530	312 030	312 794	WST 1 F/125P-E	312 388	WST 1 F/125 KP-E	313 224			
WST 1 F/150-50 *	8	50 x 65	150	50	71	85	0,480	312 537	312 795	WST 1 F/150-50-E *	312 560	WST 1 F/150-50 K-E*	313 225	
WST 1 F/150-50 P		62 x 65	175				0,490	312 538	312 796	WST 1 F/150-50P-E	312 561	WST 1 F/150-50 KP-E	313 226	
WST 1 F/150-80 *	10	35 x 65	150	105			80	0,540	312 539	312 797	WST 1 F/150-80-E *	312 562	WST 1 F/150-80 K-E*	313 227
WST 1 F/150-80 P		47 x 65	175		0,550	312 540		312 798	WST 1 F/150-80P-E	312 563	WST 1 F/150-80 KP-E	313 228		
WST 1 F/150 *	12	25 x 65	150	100	85	0,580	312 040		WST 1 F/150-E *	312 564	WST 1 F/150 K-E	313 229		
WST 1 F/150 P		37 x 65	175			0,590	312 050		WST 1 F/150P-E	312 565	WST 1 F/150 KP-E	313 230		
WST 1 F/200-100 *		50 x 65	200			0,680	312 831							
WST 1 F/200-100 P	62 x 65	225	0,700	312 832										
WST 1 F/200-140 *	14	30 x 65	200	155	140	0,670	312 833							
WST 1 F/200-140 P		42 x 65	225			0,680	312 834							
WST 1 F/250-140 *		55 x 65	250	0,740		312 835								
WST 1 F/250-140 P		67 x 65	275	0,750		312 836								



S 1 CABLE CARRIERS AND ACCESSORIES - Steel type -



acid
proof

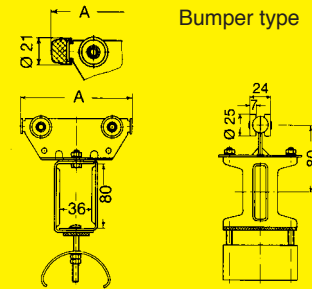

Lead Carriers for flatform cables

Type	for Carrier type	A mm	Weight kg	Order-No.	with patented nut Order-No. **	Type	Order-No.	Type	Order-No.
MST 1 F/ 85 *	WST 1 F/ 85	85	0,730	312 080	312 799	MST 1 F/ 85-E *	312 382	MST 1 F/ 85 K-E *	313 231
MST 1 F/ 85 P	WST 1 F/ 85 P	110	0,740	312 090	312 800	MST 1 F/ 85 P-E	312 389	MST 1 F/ 85 KP-E	313 232
MST 1 F/125-50 *	WST 1 F/125-50	125	0,830	312 535	312 801	MST 1 F/125-50-E *	312 521	MST 1 F/125-50 K-E *	313 233
MST 1 F/125-50 P	WST 1 F/125-50 P	150	0,840	312 536	312 802	MST 1 F/125-50 P-E	312 522	MST 1 F/125-50 KP-E	313 234
MST 1 F/125 *	WST 1 F/125	125	0,880	312 100	312 803	MST 1 F/125-E *	312 385	MST 1 F/125 K-E *	313 235
MST 1 F/125 P	WST 1 F/125 P	150	0,890	312 110	312 804	MST 1 F/125 P-E	312 390	MST 1 F/125 KP-E	313 236
MST 1 F/150-50 *	WST 1 F/150-50	150	0,850	312 541	312 805	MST 1 F/150-50-E *	312 566	MST 1 F/150-50 K-E *	313 237
MST 1 F/150-50 P	WST 1 F/150-50 P	175	0,860	312 542	312 806	MST 1 F/150-50 P-E	312 567	MST 1 F/150-50 KP-E	313 238
MST 1 F/150-80 *	WST 1 F/150-80	150	0,900	312 543	312 807	MST 1 F/150-80-E *	312 568	MST 1 F/150-80 K-E *	313 239
MST 1 F/150-80 P	WST 1 F/150-80 P	175	0,910	312 544	312 808	MST 1 F/150-80 P-E	312 569	MST 1 F/150-80 KP-E	313 240
MST 1 F/150 *	WST 1 F/150	150	0,950	312 120		MST 1 F/150-E *	312 570	MST 1 F/150 K-E *	313 241
MST 1 F/150 P	WST 1 F/150 P	175	0,960	312 130		MST 1 F/150 P-E	312 571	MST 1 F/150 KP-E	313 242
MST 1 F/200-100 *	WST 1 F/200-100	200	1,050	312 837					
MST 1 F/200-100 P	WST 1 F/200-100 P	225	1,070	312 838					
MST 1 F/200-140 *	WST 1 F/200-140	200	1,030	312 839					
MST 1 F/200-140 P	WST 1 F/200-140 P	225	1,040	312 840					
MST 1 F/250-140 *	WST 1 F/250-140	250	1,110	312 841					
MST 1 F/250-140 P	WST 1 F/250-140 P	275	1,120	312 842					

Track Clamps for flatform cables

Type	for Carrier type	x mm	Weight kg	Order-No.	with patented nut Order-No. **	Type	Order-No.
EST 1-2 F/ 85	WST 1 F/ 85 (P)	100	0,290	313 315	313 304	EST 1-2 F/ 85-E	312 383
	WST 1 F/125-50 (P)						
	WST 1 F/150-50 (P)						
EST 1-2 F/125	WST 1 F/125 (P)	100	0,370	313 316	313 308	EST 1-2 F/125-E	312 386
	WST 1 F/150-80 (P)						
EST 1-2 F/150	WST 1 F/150 (P)	100	0,410	313 317		EST 1-2 F/150-E	312 572
EST 1-2 F/100-2	WST 1 F/200-100 (P)		0,410	313 318			
EST 1-2 F/140-2	WST 1 F/200-140 (P)	125	0,430	313 319			
	WST 1 F/250-140 (P)						

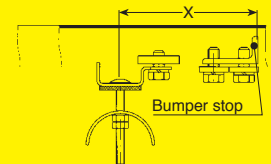

Bumper stop PS 1, PS 1-1, PS 1 G or PS 1-E to be ordered separately.

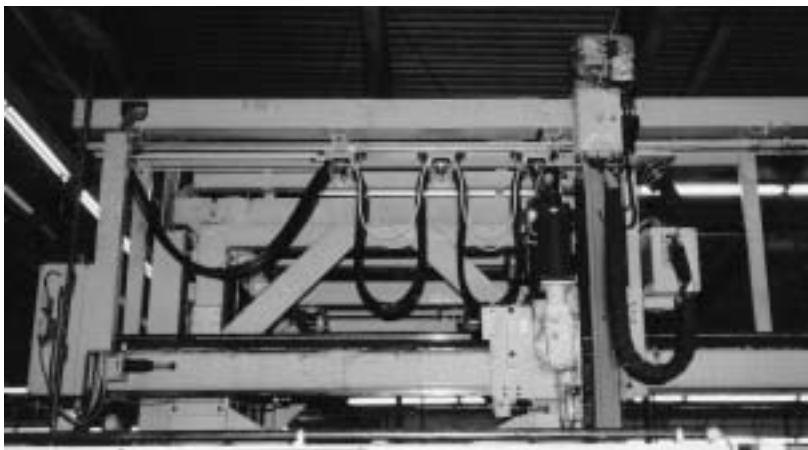

VAHLE Festoon feeding
robotic production.

* without Bumper
** with patented quick-set nut use suffix PM



S 1 CABLE CARRIERS AND ACCESSORIES – Steel type –



Engineering Data

Type	WST 1 F
Wheels	ball bearings sealed against dust and splash water hardened, galvanized Temperature resistance Lub. grease of wheels: -30° C to +125° C Travelling speed: ca. 80 m/min.
Material	Carrier body: steel, galvanized Support saddle: steel, galvanized; D = 100 & 140 aluminium Bumper: Neoprene Hardware: galvanized Temperature resistance: - 30° C to +100° C
Max. cable load	max. 22 kg per carrier
Depth of cable loop	in curves max. 0,3 x track radius, consider tension relief
for corrosive sites	use system S 1-E or K 1

Cable Carriers for flatform cables

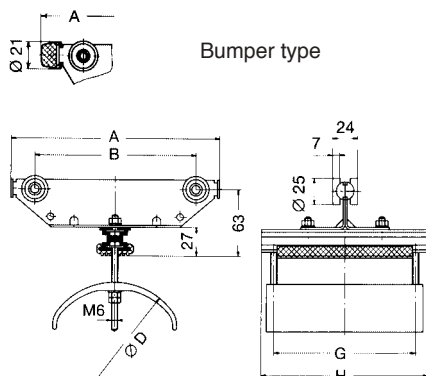

Type	max. thickn. of individual cable mm	max. clamping capacity in mm height x width	mm				Weight kg	Order-No.	
			A	B	Ø D	H			
WST 1 F/125-50 B *	8	37 x 100	125	80	50	110	134	0,630	312 902
WST 1 F/125-50 B P		50 x 100	150					0,640	312 903
WST 1 F/125-80 B *	10	22 x 100	125	80	80	110	134	0,720	312 904
WST 1 F/125-80 B P		34 x 100	150					0,730	312 905
WST 1 F/150-100 B 160 *	12	25 x 130	150	105	100	136	160	0,750	312 845
WST 1 F/150-100 B 160 P		37 x 130	175					0,760	312 846
WST 1 F/200-100 B 160 *	14	50 x 130	200	155	100	136	160	0,840	312 847
WST 1 F/200-100 B 160 P		62 x 130	225					0,850	312 848
WST 1 F/200-140 B 160 *	14	30 x 130	200	155	140	136	160	0,970	312 849
WST 1 F/200-140 B 160 P		42 x 130	225					0,980	312 850
WST 1 F/250-140 B 160 *		55 x 130	250					1,040	312 851
WST 1 F/250-140 B 160 P		67 x 130	275	205				1,050	312 852

Lead Carriers for flatform cables

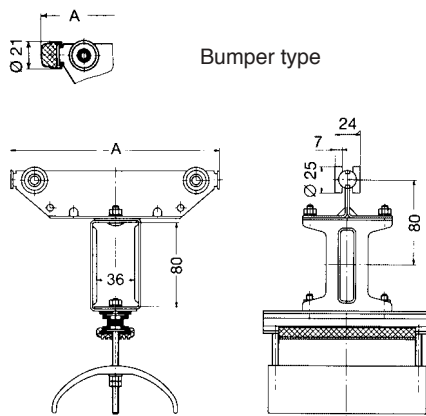

Type	for Carrier type	A mm	Weight kg	Order-No.
MST 1 F/125-50 B *	WST 1 F/125-50 B	125	1,000	312 906
MST 1 F/125-50 B P	WST 1 F/125-50 B P	150	1,010	312 907
MST 1 F/125-80 B *	WST 1 F/125-80 B	125	1,080	312 908
MST 1 F/125-80 B P	WST 1 F/125-80 B P	150	1,090	312 909
MST 1 F/150-100 B 160 *	WST 1 F/150-100 B 160	150	1,100	312 853
MST 1 F/150-100 B 160 P	WST 1 F/150-100 B 160 P	175	1,110	312 854
MST 1 F/200-100 B 160 *	WST 1 F/200-100 B 160	200	1,190	312 855
MST 1 F/200-100 B 160 P	WST 1 F/200-100 B 160 P	225	1,200	312 856
MST 1 F/200-140 B 160 *	WST 1 F/200-140 B 160	200	1,330	312 857
MST 1 F/200-140 B 160 P	WST 1 F/200-140 B 160 P	225	1,340	312 858
MST 1 F/250-140 B 160 *	WST 1 F/250-140 B 160	250	1,390	312 859
MST 1 F/250-140 B 160 P	WST 1 F/250-140 B 160 P	275	1,400	312 860

Track Clamps for flatform cables

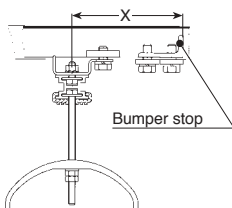

Bumper stop PS 1, PS 1-1, PS 1 G
to be ordered separately.

Type	for Carrier type	x mm	Weight kg	Order-No.
EST 1-2 F/125-50 B	WST 1 F/125-50 B (P)	100	0,470	313 313
EST 1-2 F/125-80 B	WST 1 F/125-80 B (P)		0,520	313 314
EST 1-2 F/100 B 160	WST 1 F/150-100 B 160 (P)	100	0,560	313 311
	WST 1 F/200-100 B 160 (P)	115		
EST 1-2 F/140 B 160	WST 1 F/200-140 B 160 (P)	115	0,700	313 312
	WST 1 F/250-140 B 160 (P)	140		



S 1 CABLE CARRIERS AND ACCESSORIES – Steel swivel type –



acid
proof



Engineering Data

Type	WST 1 R	WST 1 R-E
Wheels	ball bearings sealed against dust and splash water hardened, galvanized Temperature resistance: Lub. grease of wheels: -30° C to +125° C Travelling speed: ca. 80 m/min.	sealed ball bearing stainless steel, V 4 A -30° C to + 150° C ca. 80 m/min.
Material	Carrier body: steel, galvanized Support saddle: Polyamid Bumper: Neoprene Hardware: galvanized Temperature resistance: - 30° C to +100° C	V 4 A, stainless steel Polypropylene Neoprene V 4 A, stainless steel - 10° C to +80° C
Max. cable load	max. 22 kg per carrier	max. 12 kg per carrier
Depth of cable loop	in curves max. 0,3 x track radius; consider tension relief	
for corrosive sites	use system S 1-E or K 1	



Bumper type

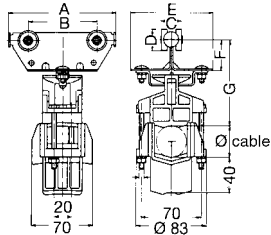

Cable Carriers for round cables and hoses

Type	Cable Ø	A	B	C	D	E	F	G	Weight kg	Order-No.	Type	Order-No.
		mm										
WST 1 R/ 85 *	5 mm to 38 mm	85	48	24	25	85	36	99	0,430	312 491	WST 1 R/ 85-E *	312 523
WST 1 R/ 85 P		110							0,460	312 492	WST 1 R/ 85 P-E	312 524
WST 1 R/125 *		125	80	24	25	97	36	99	0,540	312 493	WST 1 R/125-E *	312 525
WST 1 R/125 P		150							0,570	312 494	WST 1 R/125 P-E	312 526



Bumper type

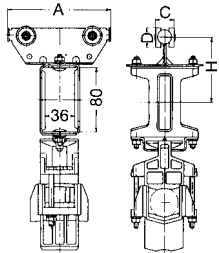

Lead Carriers for round cables and hoses

Type	for Carrier type	A	C	D	H	Weight kg	Order-No.	Type	Order-No.
		mm							
MST 1 R/ 85 *	WST 1 R/ 85	85	24	25	80	0,780	312 495	MST 1 R/ 85-E *	312 527
MST 1 R/ 85 P	WST 1 R/ 85 P	110				0,810	312 496	MST 1 R/ 85 P-E	312 528
MST 1 R/125 *	WST 1 R/125	125				0,890	312 497	MST 1 R/125-E *	312 529
MST 1 R/125 P	WST 1 R/125 P	150				0,920	312 498	MST 1 R/125 P-E	312 530

Track Clamp for round cables and hoses

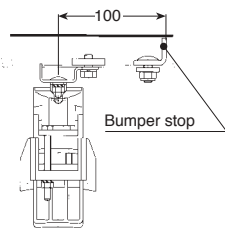

Type	for Carrier type	x mm	Weight kg	Order-No.	Type	Order No.
EST 1-2 R	WST 1 R (all types)	80	0,340	313 321	EST 1 R-E	312 531

Bumper stop PS 1, PS 1-1, PS 1 G, PS 1-E to be ordered separately.

Support Saddle for round cables and hoses for additional tiers

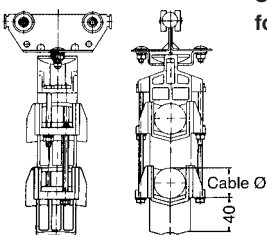

Type	for Carrier type	Weight kg	Order-No.	Type	Order-No.
LAR	WST 1 R (all types)	0,110	312 500	LAR-E	312 532

* without Bumper



S 1 CABLE CARRIERS AND ACCESSORIES

- Steel type -



Engineering Data

Type	WST 1 R/250, WST 1 R/250 P
Wheels	ball bearings sealed against dust and splash water hardened, galvanized Temperature resistance Lub. grease of wheels: -30° C to +125° C Travelling speed: ca. 80 m/min.
Material	Carrier body: steel, galvanized Cable-loop: Polyamid Support saddle: Polyamid Hardware: galvanized Temperature resistance: - 30° C to +100° C
Max. cable load	max. 22 kg per carrier WST 1 R/250 (P)
for corrosive sites	use system S 1-E or K 1

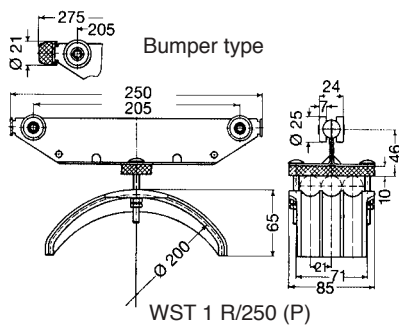

Cable Carriers for round cables and hoses

Type	max. cable-Ø mm	Weight kg	Order-No.
WST 1 R/250 *	3 x Ø 20	0,660	312 060
WST 1 R/250 P		0,690	312 070



Lead Carriers for round cables and hoses

Support saddle same as for cable carriers

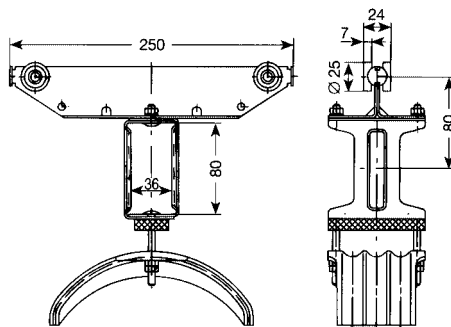

Type	for Carrier type	A mm	Weight kg	Order-No.
MST 1 R/250 *	WST 1 R/250	250	1,000	312 140
MST 1 R/250 P	WST 1 R/250 P	275	1,030	312 150

Track Clamp for round cables and hoses

Support saddle same as for cable carriers

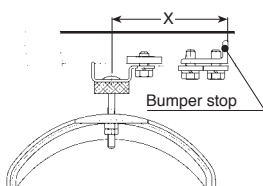

Bumper stop PS 1, PS 1-1, PS 1 G to be ordered separately.

Type	for Carrier type	x mm	Weight kg	Order-No.
ES 1 R/250	WST 1 R/250	125	0,298	313 320
	WST 1 R/250 P	138		



S 1 CABLE CARRIERS AND ACCESSORIES

- Steel type -



Engineering Data

Type	WR 1-Sch, WST 1-Sch
Wheels	ball bearings sealed against dust and splash water hardened, galvanized Temperature resistance Lub. grease of wheels: -30° C to +125° C Travelling speed: ca. 80 m/min.
Material	Carrier body: steel, galvanized S-Hook: steel, galvanized Cable-loop: Polyamid Hardware: galvanized Temperature resistance: - 30° C to +100° C
Max. cable load	max. 10 kg per carrier WR 1-Sch max. 20 kg per carrier WST 1-Sch
for corrosive sites	use system S 1-E or K 1

Cable Carriers for round cables and hoses

WR 1-Sch

WST 1-Sch

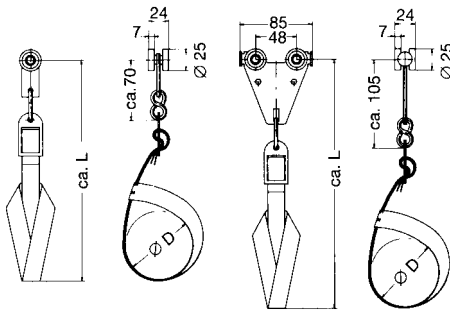

Type	Ø D mm	L mm	Weight kg	Order-No.
WR 1-Sch/ 80	80	210	0,100	312 900
WR 1-Sch/160	160	290	0,110	312 901
WST 1-Sch/ 80	80	240	0,270	312 875
WST 1-Sch/160	160	320	0,280	312 876

Installation information:

1. prepare ribbon ends as shown
2. pull all ends thru flap
3. form a loop
4. attach flap to S-hook

1.



2.

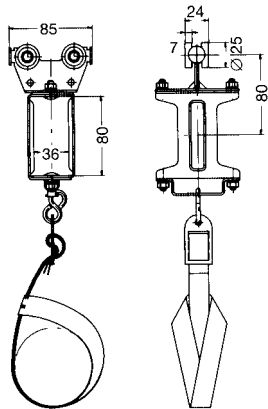

Lead Carriers for round cables and hoses

Type	for Carrier type	Weight kg	Order-No.
MST 1-Sch/80	WR 1-Sch/80	0,680	312 877
	WST 1-Sch/80		
MST 1-Sch/160	WR 1-Sch/160	0,690	312 878
	WST 1-Sch/160		

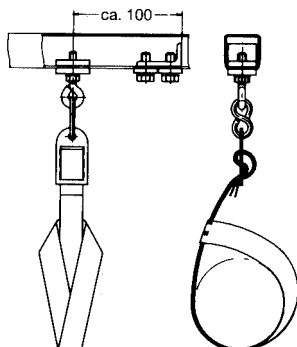

Bumper stop PS 1, PS 1-1 or PS 1 G to be ordered separately.

Track Clamps for round cables and hoses

Type	for Carrier type	Weight kg	Order-No.
EST 1-2-Sch/ 80	WR 1-Sch/80	0,140	312 879
	WST 1-Sch/80		
EST 1-2-Sch/160	WR 1-Sch/160	0,150	312 880
	WST 1-Sch/160		



S 1 CONTROL CARRIER



acid proof



Control Carriers with multiple plug-in

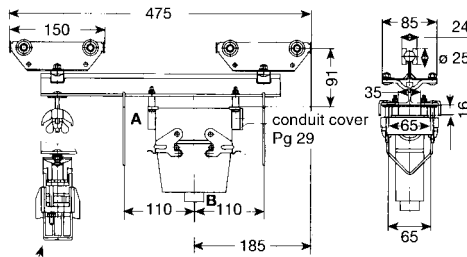

ST-ST 1 R saddle for round cable

Type *	plug-in-device DIN 43652	Weight kg	Order No.
for flat cable			
ST-ST 1/16	16pole	2,100	312 685
ST-ST 1/24	24pole	2,300	316 386
for round cable			
ST-ST 1 R/16	16pole	2,200	312 815
ST-ST 1 R/24	24pole	2,400	312 816

Carrier body: steel, galvanized
Wheels: steel ball bearings
Support bar: aluminium
Plug: cast iron

Cable glands for 16-poles for 24-poles
A-Side: Pg 29 A-Side: Pg 29
B-Side: Pg 21 B-Side: Pg 29

Max. cable load: 25 kg
Temperature resistance: - 30° C to +100° C

Control Carriers without Brake

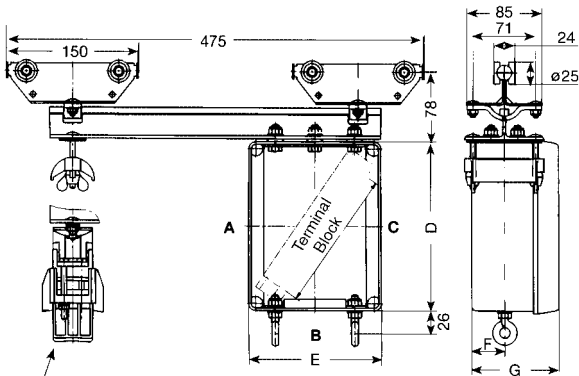

ST-ST 1 R saddle for round cable

Type *	mm				Weight kg	Order-No.	Type *	Order-No.
	D	E	F	G				
for flat cable								
ST-ST 1/A 1	190	150	38	100	2,900	312 695	ST-ST 1-E	316 332
ST-ST 1/A 2	280	200	62	140	4,300	312 694	-	-
for round cable								
ST-ST 1 R/A 1	190	150	38	100	3,000	312 817	ST-ST 1 R-E	312 819
ST-ST 1 R/A 2	280	200	62	140	4,400	312 818	-	-

Carrier body: steel, galvanized
Wheels: steel ball bearings
Support bar: aluminium

Terminal box: noryl (to be grounded, use clamp EK 2,5 NPA)

Max. cable load: 25 kg
Temperature resistance: - 30° C to +100° C

steel, stainless
bearings stainless
steel, stainless

Possible Cable gland combinations:

ST-ST 1/A 1 ST-ST 1 R/A 1 ST-ST 1-E & ST-ST 1 R-E			ST-ST 1/A 2 ST-ST 1 R/A 2		
Cable glands	max. number A-Side	max. number B-Side	Cable glands	max. number A-Side	max. number B-Side
PG 16	6	2	PG 16	12	6
PG 21	5	1	PG 21	10	6
PG 29	3	1	PG 29	8	4
PG 36	2	1	PG 36	4	1
PG 42	2	-	PG 42	3	1
PG 48	2	-	PG 48	3	1

Max. length of Terminal Block A 1 = 130 mm
A 2 = 220 mm

Brake spring for Control Carrier ST - ST 1

The braking device can be installed as an option.

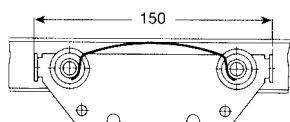

Type	Material	Weight kg	Order-No.
BF 1	stainless steel	0,007	310 860



Brake for Control Carrier

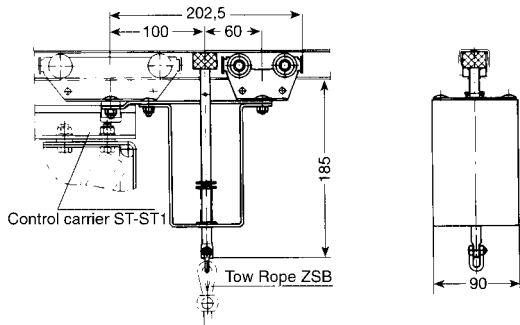

Type	Weight kg	Order-No.
BS 1	1,740	312 698

Carrier: Steel, galvanized
Wheels: Steel ball bearings

Brake for Control Carrier with AC magnet (WM)

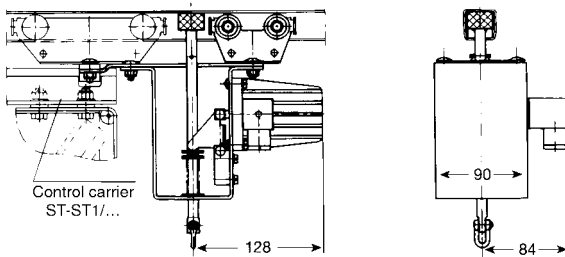

Type	Weight kg	Order-No.
BS 1-WM	2,900	312 699

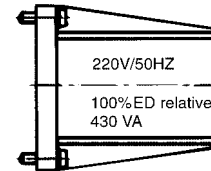

Tow Rope and Grip for Brake BS 1

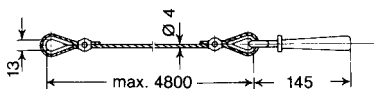

Type	Standard length mm	Weight kg	Order-No.
ZSB	5000	0,250	310 850



S 2 TRACK AND ACCESSORIES

acid proof

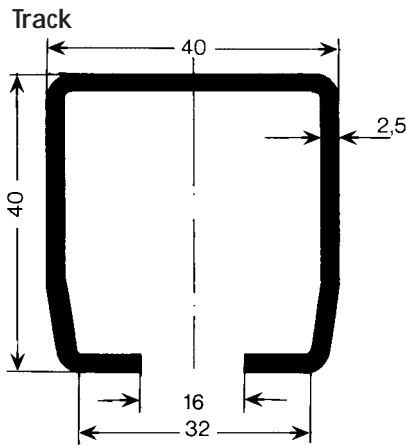

Type	S 2	S 2-E
Order-No. -in 6 m sections	316 636	316 646
Order-No. -in 4 m sections	316 634	316 644
Order-No. -surcharge for curves	310 480	315 372
for Carriers type	WS 2 and WST 2	WST 2-E
Material	steel, galvanized	V 4 A, stainless steel
Supply lengths	6 m and 4 m	
Standard support spacing	2,5 m; 1,25 m in curves	
Moment of inertia Jx	6,7 cm ⁴	6,7 cm ⁴
Section modulus Wx	3,1 cm ³	3,1 cm ³
Weight	2,490 kg/mm	2,490 kg/m

Horizontal Curves w/min. radius of 1 m are ready available. Consult factory for specials. **Support spacing for tracks see diagram on page 47.**

Hanger underhung

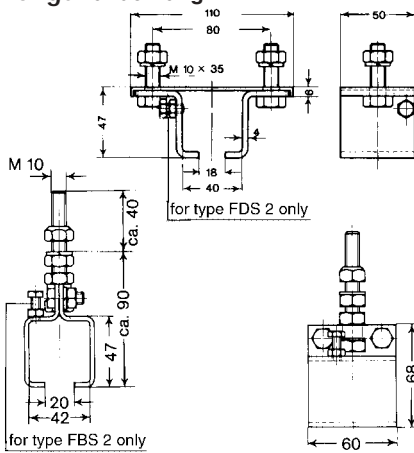

Type	Sliding hanger ADS 2*	Fixpoint hanger FDS 2	Sliding hanger ADS 2-E*	Fixpoint hanger FDS 2-E
Order-No.	315 200	315 210	315 357	315 356
Material	steel, galvanized		V 4 A, stainless steel	
Weight	0,310 kg	0,320 kg	0,310 kg	0,320 kg

Type	Sliding hanger ABS 2*	Fixpoint hanger FBS 2
Order-No.	315 140	315 150
Material	steel, galvanized	
Weight	0,370 kg	0,380 kg

Hanger underhung for HK support

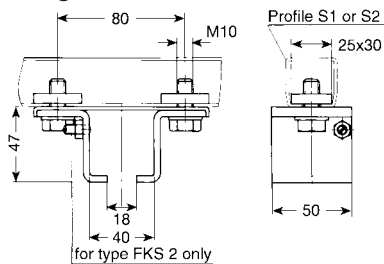

Type	Sliding hanger AKS 2*	Fixpoint hanger FKS 2	Sliding hanger AKS 2-E*	Fixpoint hanger FKS 2-E
Order-No.	315 220	315 230	315 379	315 380
Material	steel, galvanized		V 4 A, stainless steel	
Weight	0,490 kg	0,500 kg	0,490 kg	0,500 kg

Hanger lateral

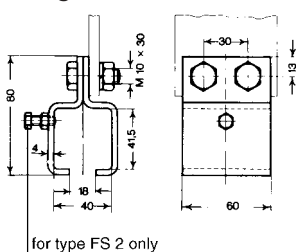

Type	Sliding hanger AS 2*	Fixpoint hanger FS 2
Order-No.	315 030	315 040
Material	steel, galvanized	
Weight	0,470 kg	0,480 kg

Joint Clamp

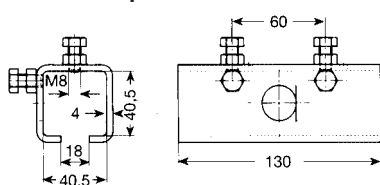

Type	VS 2	VS 2-E
Order-No.	315 050	315 355
Material	steel, galvanized	
Weight	0,680 kg	0,680 kg



S 2 ACCESSORIES

acid
proof



Joint Clamp, lock type (Patent pending)

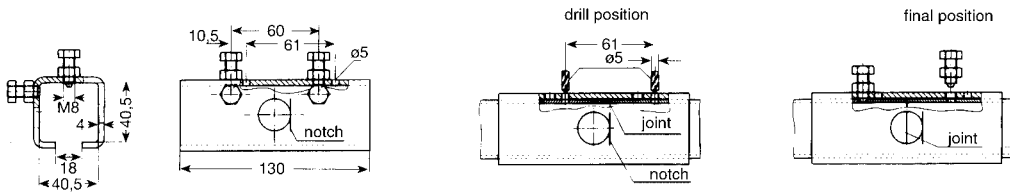

Type	VS 2-F
Order-No.	316 522
Material	steel, galvanized
Weight	0,680 kg

End Cap

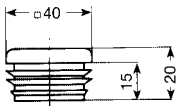

Type	K 40
Order-No.	316 449
Material	polyethylene
Weight	0,009 kg

Bumper stop

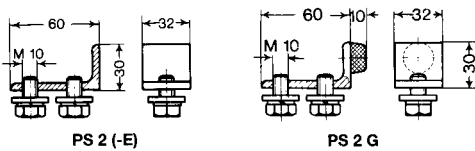

Type	PS 2	PS 2 G	PS 2-E
Order-No.	315 170	315 190	315 358
Material	steel, galvanized	steel, galvanized	V 4 A, stainless steel
Weight	0,150 kg	0,170 kg	0,150 kg

Flat nut w/bolt and washer

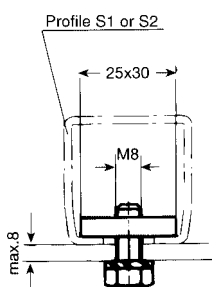

Type	M 8x20
Order-No.	312 600
Material	steel, galvanized
Weight	0,044 kg



S 2 ACCESSORIES

acid proof



Standard Brackets

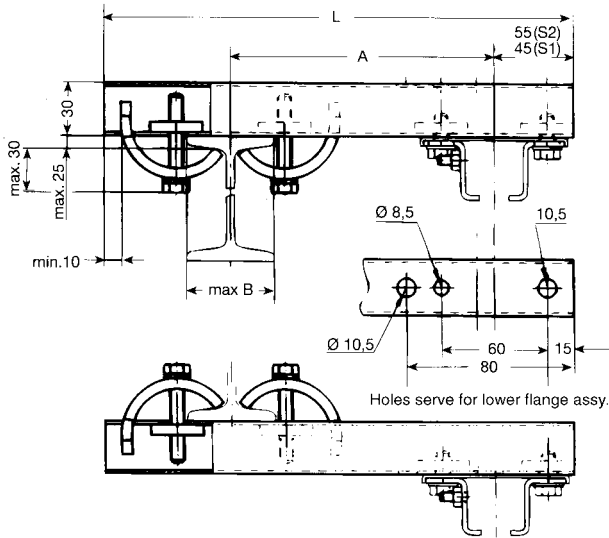

Choose dim. A per local requirements and make sure that hoist wheels have enough clearance.

Select next larger size bracket when your I-Beam dim. B is more than 210 mm and refer to page 23 for heavy duty brackets.

Type	Material	Weight kg	A (adjustable) mm	L mm	max. B mm	Order-No.	Type	Mat.	Order-No.
HK 200	steel galvanized	0,980	200	400	210	310 220	HK 200-E	stainl. steel V 4 A	312 510
HK 300		1,130	300	500	210	310 230	HK 300-E		312 511
HK 400		1,290	400	600	210	310 240	HK 400-E		312 512
HK 500		1,430	500	700	210	310 250	HK 500-E		312 513

Hangers AKS 2 and FKS 2 to be ordered separately.

Bracket Bars for HK

Type	Material	Weight kg	L mm	Order-No.	Type	Mat.	Order-No.
S 1-400	steel galvanized	0,620	400	310 600	S 1E-400	stainl. steel V 4 A	312 515
S 1-500		0,780	500	310 610	S 1E-500		312 516
S 1-600		0,930	600	310 620	S 1E-600		312 517
S 1-700		1,090	700	310 630	S 1E-700		312 518

Claws for HK

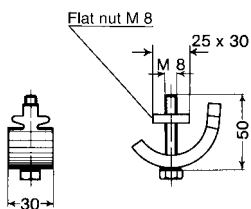

Type	SP	SP-E
Order-No.	310 390	312 514
Material	steel, galvanized	V 4 A, stainless steel
Weight	0,200 kg	0,200 kg

Flat nut M 8 separately available.
Order-No. 310 955

Flat nut M 8 E stainless separately available.
Order-No. 312 545

Support Attachment for HK

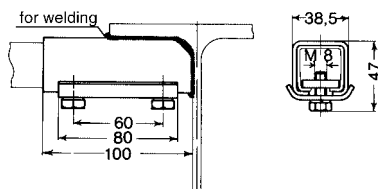

Type	AH 1
Order-No.	310 400
Material	steel, galvanized
Weight	0,460 kg

Bracket bar sections and hangers to be ordered separately.



S 2 ACCESSORIES

acid proof



General Assembly of Heavy Duty Bracket

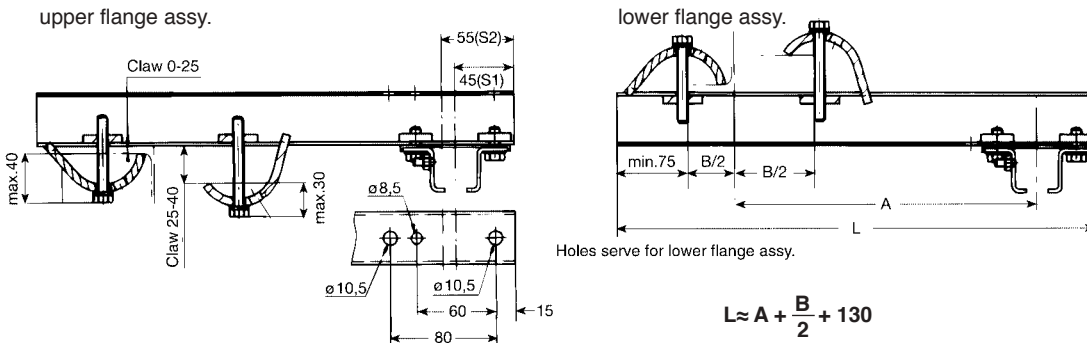

Bracket Bars for HK heavy duty

Type	Material	Weight kg	Dim. L mm	Order-No.	Type	Mat.	Order-No.
S 2- 400	steel galvanized	0,996	400	315 402	S 2E- 400	stainl. steel V 4 A	316 513
S 2- 500		1,245	500	315 403	S 2E- 500		316 514
S 2- 600		1,494	600	315 404	S 2E- 600		316 515
S 2- 700		1,743	700	315 405	S 2E- 700		316 516
S 2- 800		1,992	800	315 406	S 2E- 800		316 517
S 2- 900		2,241	900	315 407	S 2E- 900		316 518
S 2-1000		2,490	1000	315 408	S 2E-1000		316 519
S 2-1100		2,739	1100	315 409	S 2E-1100		316 520
S 2-1200		2,988	1200	315 410	S 2E-1200		316 521

Claws for HK heavy duty

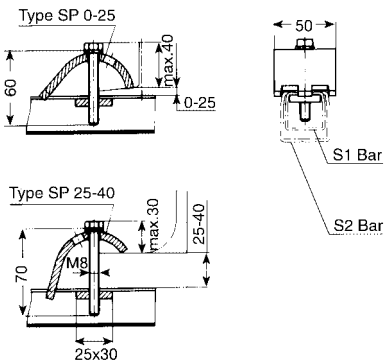

Type	SP 0-25	SP 0-25-E
Order-No.	312 643	316 690
Material	steel, galvanized	V 4 A (stainless steel)
Weight	0,286 kg	0,286 kg

Type	SP 25-40	SP 0-40-E
Order-No.	312 644	316 695
Material	steel, galvanized	V 4 A (stainless steel)
Weight	0,287 kg	0,287 kg

Support Attachment for HK heavy duty

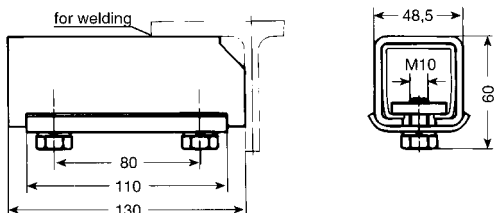

Type	AH 2
Order-No.	310 989
Material	steel, galvanized
Weight	0,940 kg

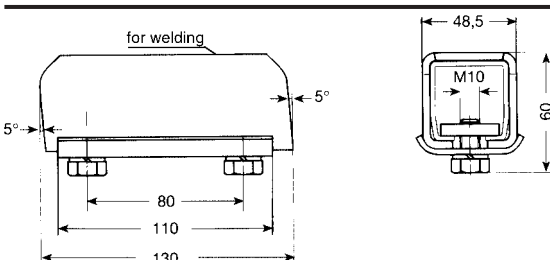

Type	AH 2-2
Order-No.	312 648
Material	steel, galvanized
Weight	0,854 kg



S 2 CABLE CARRIERS AND ACCESSORIES

Polyamid type –



Engineering Data

Type	WS 2 F
Wheels	Hardened and galvanized steel rollers with precision ball bearing, sealed against dust and splash water Temperature resistance Lub. grease of wheels: – 30° C to + 125° C Travelling speed: max. 80 m/min.
Material	Carrier body: Polyamid Support saddle: Polyamid Hardware: galvanized Temperature resistance: – 30° C to +100° C
Max. cable load	max. 22 kg per carrier
for corrosive sites	use system S 2-E

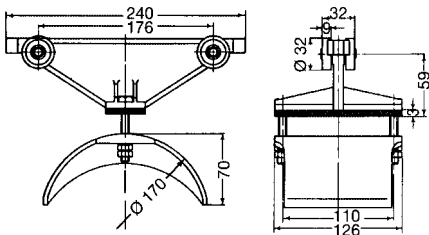

Cable Carrier for flatrom cable

Type	max. thickness of individual cable mm	max. clamping capacity in mm height x width	Weight kg	Order-No.
WS 2 F/240	17	35 x 100	0,520	315 070

Lead Carrier for flatrom cable

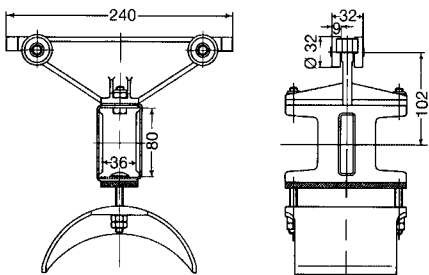

Type	for Carrier type	Weight kg	Order-No.
MS 2 F/240	WS 2 F/240	1,000	315 090

Track Clamp for flatrom cable

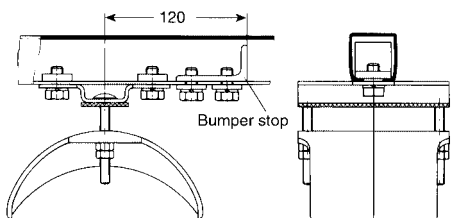

Type	for Carrier type	Weight kg	Order-No.
ES 2 F/240	WS 2 F/240	0,710	315 110

Bumper stop PS 2 (PS 2 G) to be ordered separately.



S 2 CABLE CARRIERS AND ACCESSORIES

- Steel type -



hex. nut version



quick-set nut version

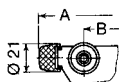

Bumper type

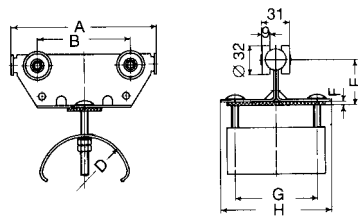

Engineering Data

Type	WST 2 F (for flatform cable)
Wheels	Hardened and galvanized steel rollers with precision ball bearing, sealed against dust and splash water Temperature resistance Lub. grease of wheels: - 30° C to + 125° C Travelling speed: ca. 100 m/min.
Material	Carrier body: steel, galvanized Support saddle: galvanized steel Bumper: Neoprene Hardware: galvanized Temperature resistance: - 30° C to +100° C with patented nut support saddle: Polyamid
Max. cable load	max. 28 kg per carrier
Depth of cable loop	in curves max. 0,3 x track radius; consider tension relief
for corrosive sites	use system S 2-E

Cable Carriers for flatform cables

Type	max. thckn. of individual cable mm	max. clamping capacity in mm height x width	A	B	Ø D	G	H	Weight kg	with patented nut Order-No. **	Order-No.
			mm							
WST 2 F/ 85 *	8	17 x 65	85	43	50	71	85	0,460	316 493	316 170
WST 2 F/ 85 P		29 x 65	110					0,470	316 494	316 180
WST 2 F/125-50 *		37 x 65	125	0,560				316 495	315 381	
WST 2 F/125-50 P	50 x 65	150	0,570	316 496	315 382					
WST 2 F/125 *	10	22 x 65	125	80	80	97	0,630	316 497	316 190	
WST 2 F/125 P		34 x 65	150				0,640	316 498	316 200	
WST 2 F/150-50 *	8	50 x 65	150	50	71	85	0,590	316 499	315 383	
WST 2 F/150-50 P		62 x 65	175				0,600	316 500	315 384	
WST 2 F/150-80 *	10	35 x 65	150	105	80	85	0,660	316 501	315 385	
WST 2 F/150-80 P		47 x 65	175				0,670	316 502	315 386	
WST 2 F/150 *	12	25 x 65	150	100	100	85	0,700		316 210	
WST 2 F/150 P		37 x 65	175				0,710		316 220	
WST 2 F/200-100 *		50 x 65	200				0,800		316 576	
WST 2 F/200-100 P	62 x 65	225	0,810		316 577					

Lead Carriers for flatform cables

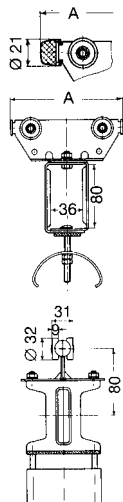

Bumper type

Type	for Carrier type	A mm	Weight kg	with patented nut Order-No. **	Order-No.
MST 2 F/ 85 *	WST 2 F/ 85	85	0,830	316 503	316 230
MST 2 F/ 85 P	WST 2 F/ 85 P	110	0,840	316 504	316 240
MST 2 F/125-50 *	WST 2 F/125-50	125	0,940	316 505	315 389
MST 2 F/125-50 P	WST 2 F/125-50 P	150	0,950	316 506	315 390
MST 2 F/125 *	WST 2 F/125	125	1,010	316 507	316 250
MST 2 F/125 P	WST 2 F/125 P	150	1,020	316 508	316 260
MST 2 F/150-50 *	WST 2 F/150-50	150	0,960	316 509	315 391
MST 2 F/150-50 P	WST 2 F/150-50 P	175	0,970	316 510	315 392
MST 2 F/150-80 *	WST 2 F/150-80	150	1,030	316 511	315 393
MST 2 F/150-80 P	WST 2 F/150-80 P	175	1,040	316 512	315 394
MST 2 F/150 *	WST 2 F/150	150	1,070		316 270
MST 2 F/150 P	WST 2 F/150 P	175	1,080		316 280
MST 2 F/200-100 *	WST 2 F/200-100	200	1,170		316 578
MST 2 F/200-100 P	WST 2 F/200-100 P	225	1,180		316 579

Track clamps for flatform cables

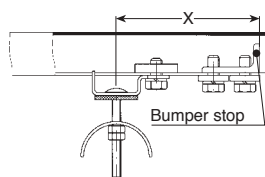

Bumper stop PS 2 (PS 2 G, PS 2-E) to be ordered separately.

Type	for Carrier type	A mm	Weight kg	with patented nut Order-No. **	Order-No.
EST 1-2 F/ 85	WST 2 F/ 85 (P)	100	0,290	313 304	313 315
	WST 2 F/125-50 (P)				
	WST 2 F/150-50 (P)				
EST 1-2 F/125	WST 2 F/125 (P)	100	0,370	313 308	313 316
	WST 2 F/150-80 (P)				
EST 1-2 F/150	WST 2 F/150 (P)	100	0,410		313 317
EST 1-2 F/100-2	WST 2 F/200-100 (P)	140	0,410		313 318

* without Bumper
** with patented nut use suffix PM, e.g. WST 2 F/85 - PM for Order-No. 316 493



S 2 CABLE CARRIERS AND ACCESSORIES

- Steel type -



Engineering Data

Type	WST 2 F (for flatform cable)
Wheels	Hardened and galvanized steel rollers with precision ball bearing, sealed against dust and splash water Temperature resistance Lub. grease of wheels: - 30° C to + 125° C Travelling speed: ca. 100 m/min.
Material	Carrier body: steel, galvanized Support saddle: galvanized steel; D = 100 and 140 aluminium Bumper: Neoprene Hardware: galvanized Temperature resistance: - 30° C to +100° C
Max. cable load	max. 28 kg per carrier
Depth of cable loop	in curves max. 0,3 x track radius; consider tension relief
for corrosive sites	use system S 2-E

Cable carriers for flatform cables

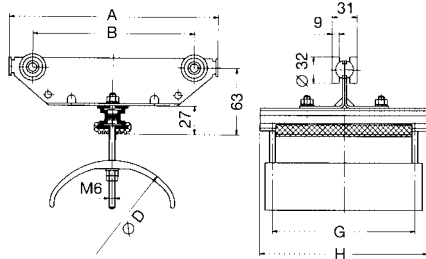

Type	max. thicken. of individual cable mm	max. clamping capacity in mm height x width	mm				Weight kg	Order-No.	
			A	B	Ø D	H			
WST 2 F/125-50 B *	8	37 x 100	125	80	50	110	134	0,730	316 580
WST 2 F/125-50 B P		50 x 100	150					0,740	316 581
WST 2 F/125-80 B *	10	22 x 100	125	80	80	110	134	0,830	316 602
WST 2 F/125-80 B P		34 x 100	150					0,840	316 603
WST 2 F/150-100 B 160 *	12	25 x 130	150	105	100	136	160	0,850	316 582
WST 2 F/150-100 B 160 P		37 x 130	175					0,860	316 583
WST 2 F/200-100 B 160 *	14	50 x 130	200	155	100	136	160	0,940	316 584
WST 2 F/200-100 B 160 P		62 x 130	225					0,950	316 585
WST 2 F/200-140 B 160 *	14	30 x 130	200	155	140	136	160	1,070	316 586
WST 2 F/200-140 B 160 P		42 x 130	225					1,080	316 587
WST 2 F/250-140 B 160 *	14	55 x 130	250	205	140	136	160	1,140	316 588
WST 2 F/250-140 B 160 P		67 x 130	275					1,150	316 589

Lead carriers for flatform cables

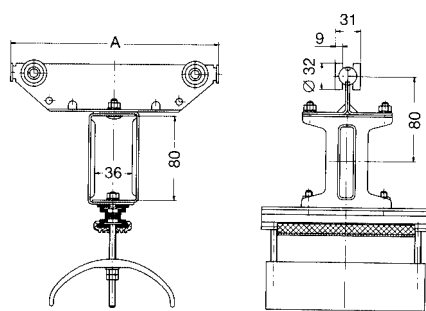

Type	for Carrier type	A mm	Weight kg	Order-No.
MST 2 F/125-50 B *	WST 2 F/125-50 B	125	1,100	316 590
MST 2 F/125-50 B P	WST 2 F/125-50 B P	150	1,110	316 591
MST 2 F/125-80 B *	WST 2 F/125-80 B	125	1,180	316 604
MST 2 F/125-80 B P	WST 2 F/125-80 B P	150	1,190	316 605
MST 2 F/150-100 B 160 *	WST 2 F/150-100 B 160	150	1,200	316 592
MST 2 F/150-100 B 160 P	WST 2 F/150-100 B 160 P	175	1,210	316 593
MST 2 F/200-100 B 160 *	WST 2 F/200-100 B 160	200	1,290	316 594
MST 2 F/200-100 B 160 P	WST 2 F/200-100 B 160 P	225	1,300	316 595
MST 2 F/200-140 B 160 *	WST 2 F/200-140 B 160	200	1,430	316 596
MST 2 F/200-140 B 160 P	WST 2 F/200-140 B 160 P	225	1,440	316 597
MST 2 F/250-140 B 160 *	WST 2 F/250-140 B 160	250	1,490	316 598
MST 2 F/250-140 B 160 P	WST 2 F/250-140 B 160 P	275	1,500	316 599

Track clamps for flatform cables

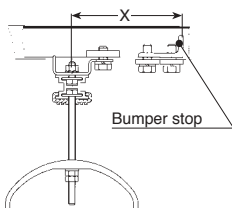

Bumper stop PS 2 or PS 2 G to be ordered separately.

Type	for Carrier type	x mm	Weight kg	Order-No.
EST 1-2 F/125-50 B	WST 2 F/125-50 B (P)	100	0,470	313 313
EST 1-2 F/125-80 B	WST 2 F/125-80 B (P)		0,520	313 314
EST 1-2 F/100 B 160	WST 2 F/150-100 B 160 (P)	100	0,560	313 311
	WST 2 F/200-100 B 160 (P)	115		
EST 1-2 F/140 B 160	WST 2 F/200-140 B 160 (P)	115	0,700	313 312
	WST 2 F/250-140 B 160 (P)	140		



S 2 CABLE CARRIERS

- Steel type -



acid proof



Engineering Data



Type	WST 2 F (flatform cable) WST 2 R (for round cable)	WST 2 F-E
Wheels	Hardened and galvanized steel rollers with precision ball bearing, sealed against dust and splash water Temperature resistance Lub. grease of wheels: - 30° C to + 125° C Travelling speed: ca. 100 m/min.	sealed ball bearings stainless steel, V 4 A -30° C to +150° C ca. 100 m/min.
Material	Carrier body: steel, galvanized Support saddle: galvanized steel, Polyamid and Aluminium Bumper: Neoprene Hardware: galvanized Temperature resistance: - 30° C to +100° C	V 4 A, stainless steel V 4 A, stainless steel Neoprene V 4 A, stainless steel - 30° C to +80° C
Max. cable load	max. 35 kg per carrier	max. 20 kg per carrier
Depth of cable load	in curves max. 0,3 x track radius; consider tension relief	
for corrosive sites	use system S 2-E	

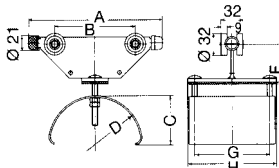

Support saddle:
steel, galvanized

Cable Carriers for flatform cables

Type	max. thckn. of individual cable mm	max. clamping capacity in mm height x width	mm								Weight kg	Order-No.	Type	Order-No.
			A	B	C	D	E	F	G	H				
WST 2 F/200	14	30 x 100	200	120	72	140	58	3	110	130	1,400	316 010	WST 2 F/200-E	315 362
WST 2 F/240	17	35 x 100	240	160	87	170	58	3	110	130	1,700	316 000	WST 2 F/240-E	315 363
WST 2 F/240-140	14	50 x 100	240	160	72	140	58	3	110	130	1,470	315 387	WST 2 F/240-140 E	315 388

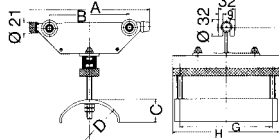

Support saddle:
aluminium

Cable Carriers for flatform cables

Type	max. thckn. of individual cable mm	max. clamping capacity in mm height x width	mm								Weight kg	Order-No.
			A	B	C	D	E	F	G	H		
WST 2 F/200 LB	14	30 x 170	200	120	45	140	94	15	180	210	1,750	316 020
WST 2 F/240 LB		50 x 170	240	160	45	140	94	15	180	210	1,900	316 030

Cable carriers with a wider clamping capacity are available.

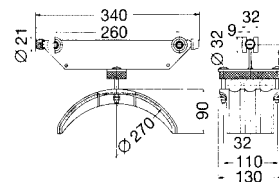

Cable Carrier for round cables

Type	max. No. of cable	max. Ø mm	Weight kg	Order-No.
WST 2 R/340	3	27	1,500	316 040

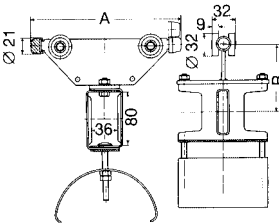

Support saddle:
as per cable carrier

Lead Carriers for flatform and round cables

Type	for Carrier type	Cable	A mm	B mm	Weight kg	Order-No.	Type	Order-No.
MST 2 F/200	WST 2 F/200	flatform	200	102	1,880	316 060	MST 2 F/200-E	315 364
MST 2 F/240	WST 2 F/240		240		2,180	316 050	MST 2 F/240-E	315 365
MST 2 F/240-140	WST 2 F/240-140		240		2,020	315 395	MST 2 F/240-140-E	315 396
MST 2 F/200 LB	WST 2 F/200 LB		200		2,230	316 070		
MST 2 F/240 LB	WST 2 F/240 LB		240		2,380	316 080		
MST 2 R/340	WST 2 R/340	round	340		1,980	316 090		

Track Clamps for flatform and round cables

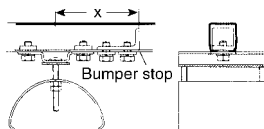

Type	for Carrier type	Cable	x mm	Weight kg	Order-No.	Type	Order-No.
EST 2 F/200	WST 2 F/200	flatform	115	1,130	316 110	EST 2 F/200-E	315 366
	WST 2 F/240-140						
EST 2 F/240	WST 2 F/240		120	1,210	316 100	EST 2 F/240-E	315 367
EST 2 F/200 LB	WST 2 F/200 LB		115	1,650	316 120		
EST 2 F/240 LB	WST 2 F/240 LB		120	1,650	316 130		
ES 2 R/340	WST 2 R/340	round	170	0,810	315 120		

Bumper stop PS 2 (PS 2 G, PS 2-E) to be ordered separately.



S 2 CABLE CARRIERS AND ACCESSORIES

- Steel swivel type -



Engineering Data

Type	WST 2 R
Wheels	ball bearings sealed against dust and splash water, steel hardened, galvanized Temperature resistance Lub. grease of wheels: - 30° C to + 125° C Travelling speed: ca. 80 m/min.
Material	Carrier body: steel, galvanized Support saddle: Polyamid Bumper: Neoprene Hardware: galvanized Temperature resistance: - 30° C to +100° C
Max. cable load	max. 22 kg per carrier
Depth of cable loop	for curves max. 0,3 x track radius; consider tension relief
for corrosive sites	use system S 2-E or K 1

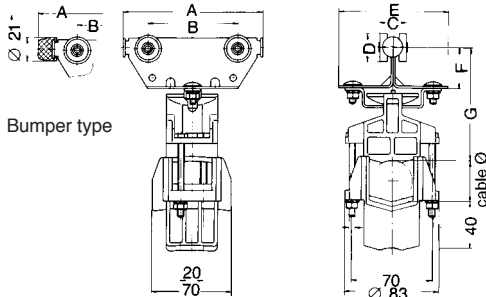

Cable Carriers for round cables and hoses

Type	cable Ø	mm							Weight kg	Order-No.
		A	B	C	D	E	F	G		
WST 2 R/ 85 *	5 mm to 38 mm	85	43	31	32	85	36	99	0,530	316 416
WST 2 R/ 85 P		110							0,550	316 417
WST 2 R/125 *		125	80	31	32	97	36	99	0,630	316 418
WST 2 R/125 P		150							0,650	316 419

Bumper type

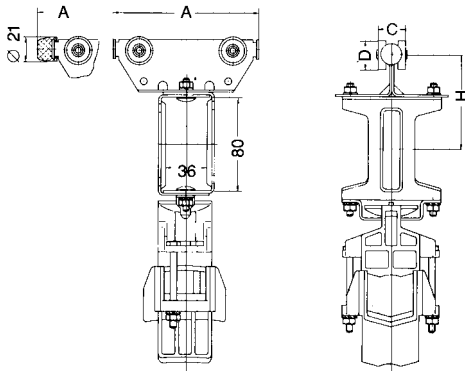

Lead Carriers for round cables and hoses

Type	for Carrier type	mm				Weight kg	Order-No.
		A	C	D	H		
MST 2 R/ 85 *	WST 2 R/ 85	85	31	32	80	0,890	316 420
MST 2 R/ 85 P	WST 2 R/ 85 P	110				0,910	316 421
MST 2 R/125 *	WST 2 R/125	125				0,990	316 422
MST 2 R/125 P	WST 2 R/125 P	150				1,010	316 423

Track Clamp for round cables and hoses

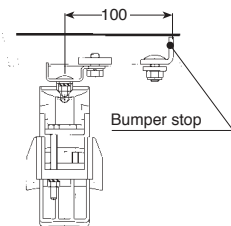

Type	for Carrier type	Weight kg	Order-No.
EST 1-2 R	WST 2 R (all types)	0,338	313 321

Bumper stop PS 2 (PS 2 G) to be ordered separately.

Support Saddle for round cables and hoses

for additional tiers

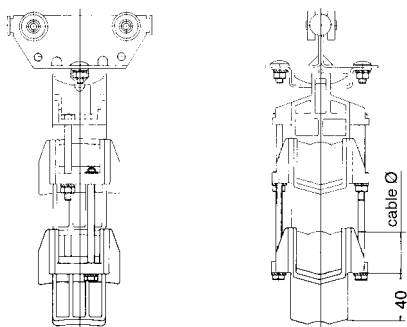

Type	for Carrier type	Weight kg	Order-No.
LAR	WST 2 R (all types)	0,110	312 500



S 2 CABLE CARRIERS AND ACCESSORIES

- Steel type -



Engineering Data

Type	WR 2-Sch, WST 2-Sch
Wheels	ball bearings sealed against dust and splash water hardened, galvanized Temperature resistance Lub. grease of wheels: - 30° C to + 125° C Travelling speed: ca. 80 m/min.
Material	Carrier body: steel, galvanized S-Hook: steel, galvanized Cable-loop: Polyamid Hardware: galvanized Temperature resistance: - 30° C to +100° C
Max. cable load	max. 15 kg per carrier WR 2-Sch max. 30 kg per carrier WST 2-Sch
for corrosive sites	use system S 2-E

Cable Carriers for round cables and hoses

WR 2-Sch

WST 2-Sch

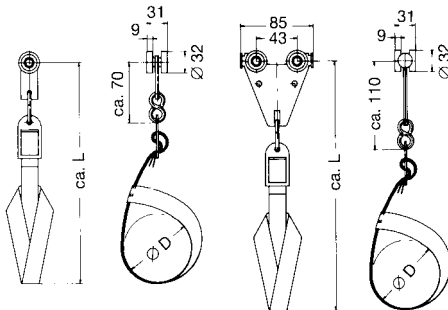

Type	Ø D mm	L mm	Weight kg	Order-No.
WR 2-Sch/ 80	80	210	0,160	316 600
WR 2-Sch/160	160	290	0,170	316 601
WST 2-Sch/ 80	80	240	0,370	316 550
WST 2-Sch/160	160	320	0,380	316 555

Installation information:

1. prepare ribbon ends as shown
2. pull all ends thru flap
3. form a loop
4. attach flap to S-hook

1.



2.

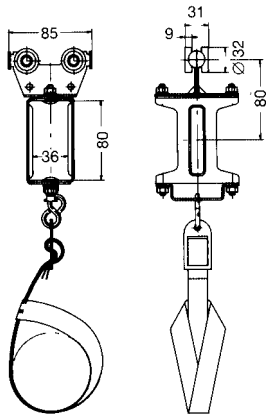
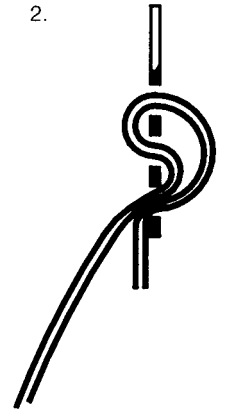

Lead Carriers for round cables and hoses

Type	for Carrier type	Weight kg	Order-No.
MST 2-Sch/80	WR 2-Sch/80	0,780	316 556
	WST 2-Sch/80		
MST 2-Sch/160	WR 2-Sch/160	0,790	316 557
	WST 2-Sch/160		

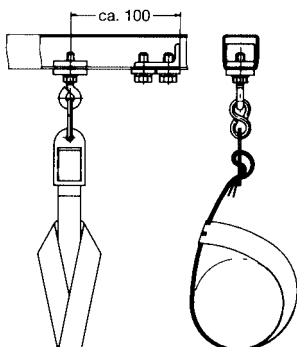

Bumper stop PS 2 or PS 2 G to be ordered separately.

Track Clamps for round cables and hoses

Type	for Carrier type	Weight kg	Order-No.
EST 1-2-Sch/ 80	WR 2-Sch/80	0,140	312 879
	WST 2-Sch/80		
EST 1-2-Sch/160	WR 2-Sch/160	0,150	312 880
	WST 2-Sch/160		



S 2 CONTROL CARRIER ACCESSORIES

acid proof



Brake for Control Carrier

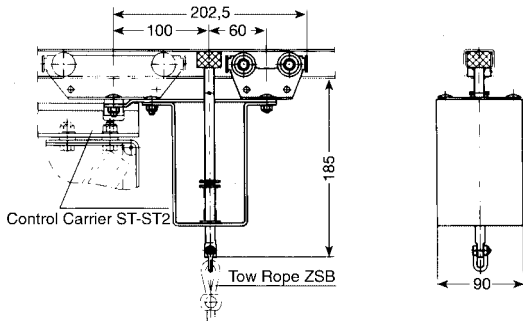

Type	Weight kg	Order-No.
BS 2	1,840	316 458

Carrier body: steel, galvanized
Wheels: steel ball bearings

Tow Rope and Grip for Brake BS 2

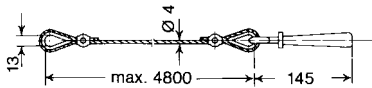

Type	Standard length mm	Weight kg	Order-No.
ZSB	5000	0,250	310 850

Brake for Control Carrier with AC magnet (WM)

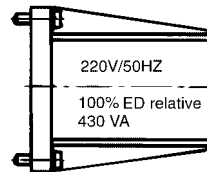
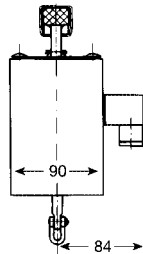
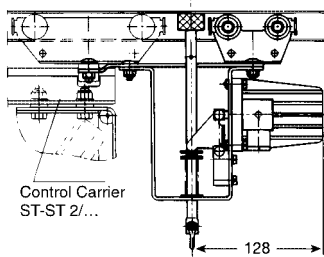

Type	Weight kg	Order-No.
BS 2-WM	3,000	316 457



S 2 motor powered control carrier



S 2 CONTROL CARRIERS

with motorized lifting device for pushbutton station

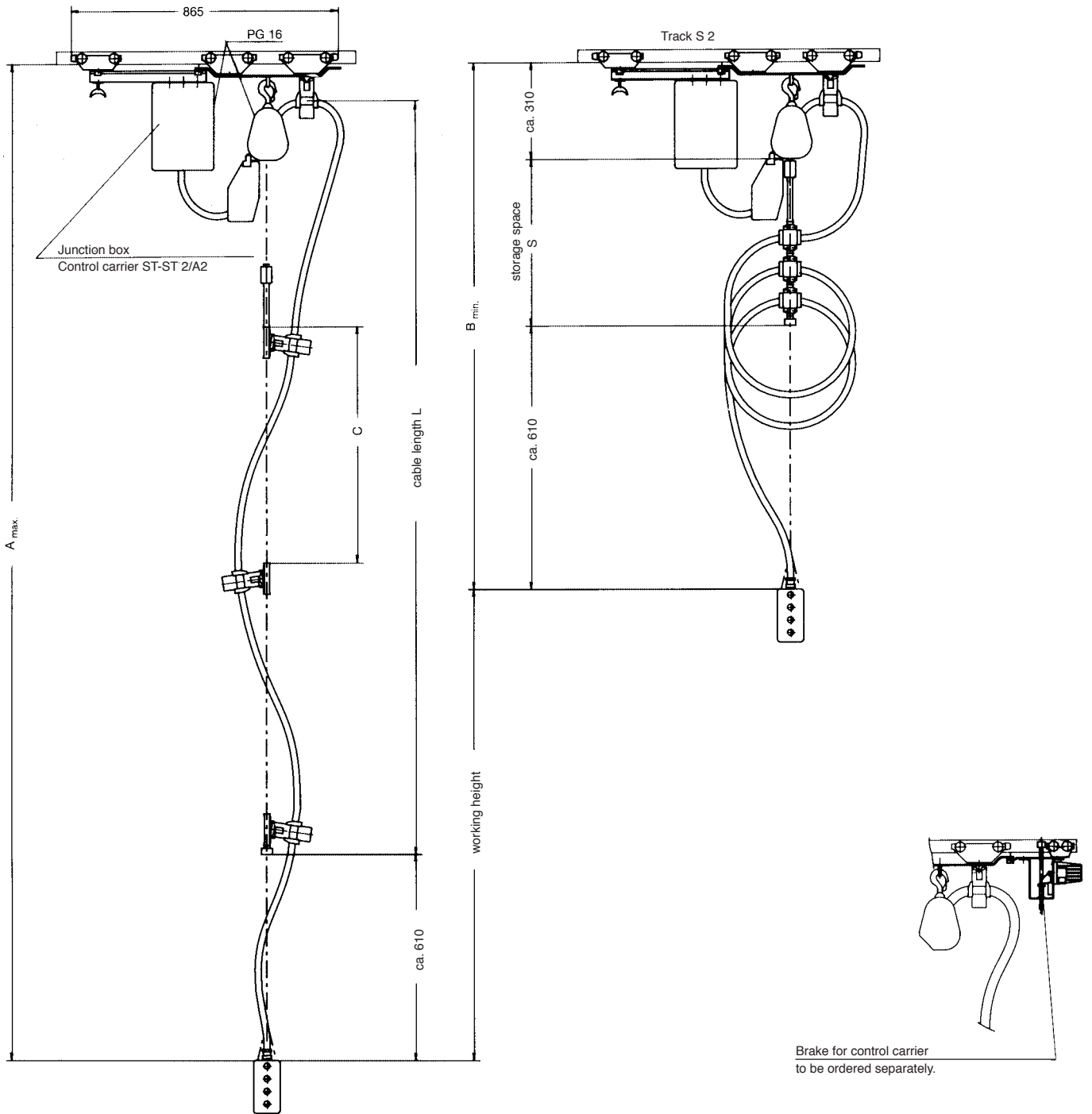

Brake for control carrier
to be ordered separately.

cable length L	= (H+S) x 1,05 (m)
attachment intervals C	= $\frac{L}{n}$ (m)
storage distance S	= n x 0,1 m + 0,2 m (m)

- H = working height (m)
- A_{max.} = lowest position of pushbutton station (m)
- B_{min.} = highest position of pushbutton station (m)
- S = storage distance (m)
- L = length of cable without connecting ends (m)
- C = attachment intervals of cable loops (m)
- n = number of cable loops

Type *	Working height H (m)	A max. (m)	B min. (m)	Storage distance S (m)	Number of cable loops (n)	Permissible load cable and push button station	Weight ca. kg	Order-No.
ST 2-H 1,3	1,3	2,55	1,25	0,33	1	52,0 kg	18,000	316 560
ST 2-H 2,6	2,6	3,95	1,35	0,43	2	51,5 kg	18,500	316 561
ST 2-H 3,9	3,9	5,35	1,45	0,53	3	51,0 kg	19,000	316 562
ST 2-H 5,2	5,2	6,75	1,55	0,63	4	50,5 kg	19,500	316 563
ST 2-H 6,5	6,5	8,15	1,65	0,73	5	50,0 kg	20,000	316 564
ST 2-H 7,8	7,8	9,55	1,75	0,83	6	49,5 kg	20,500	316 565
ST 2-H 9,1	9,1	10,95	1,85	0,93	7	49,0 kg	21,000	316 566
ST 2-H 10,4	10,4	12,35	1,95	1,03	8	48,5 kg	21,500	316 567
ST 2-H 11,7	11,7	13,75	2,05	1,13	9	48,0 kg	22,000	316 568
ST 2-H 13,0	13,0	15,15	2,15	1,23	10	47,5 kg	22,500	316 569



S 2 CONTROL CARRIERS

Installation and Electrical Connection

1. Install the track per installation information, page 47, using fix-point hangers only. Support distance in accordance to the load by control carrier, cable and pushbutton station.
2. Install the cable, including min. 3 control conductors (min. 1 mm²) to operate the lifting device as shown in the adjacent picture with the pushbutton station in the upper position. We recommend to use rubber sheathed round cable with tension relief core.
3. Mark the cable length $L = (H+S) \times 1,05$ (connecting ends to the pushbutton station and to the junction box non considered) in dimension C attachment intervals of cable loops (n).
4. Start with the first cable attachment clamp above the pushbutton station and continue to install the cable to the further attachment clamps in spiral loops at dim. C intervals (consider your cable connection length to the pushbutton).
5. Guiding the cable via the upper clamp attached to the control carrier you now enter the junction box and connect your cable to the terminal blocks.
6. The junction box must in addition be provided for 8 terminal blocks and 1 ground for the electrical connection of the lifting device.
7. The connection between the hoist and the junction box must be achieved via an 8-core plus ground cable of min. 1 mm² and in accordance to the adjacent wiring diagram.
8. Incoming power 380 V, 50 Hz, to be connected at L1, L2, L3, and ground and the control voltage 220 V, 50 Hz to the terminal clamps no. 2 and 3.
9. Wires at terminal clamps 1, 4, 5 represent connection to the keys S 1 and S 2 (up/down) in the pushbutton station.
10. The function key S 2 (down) can also be installed in an other position, for example in the crane cabin. 2 control conductors are then necessary to be provided via the cable festoon system.

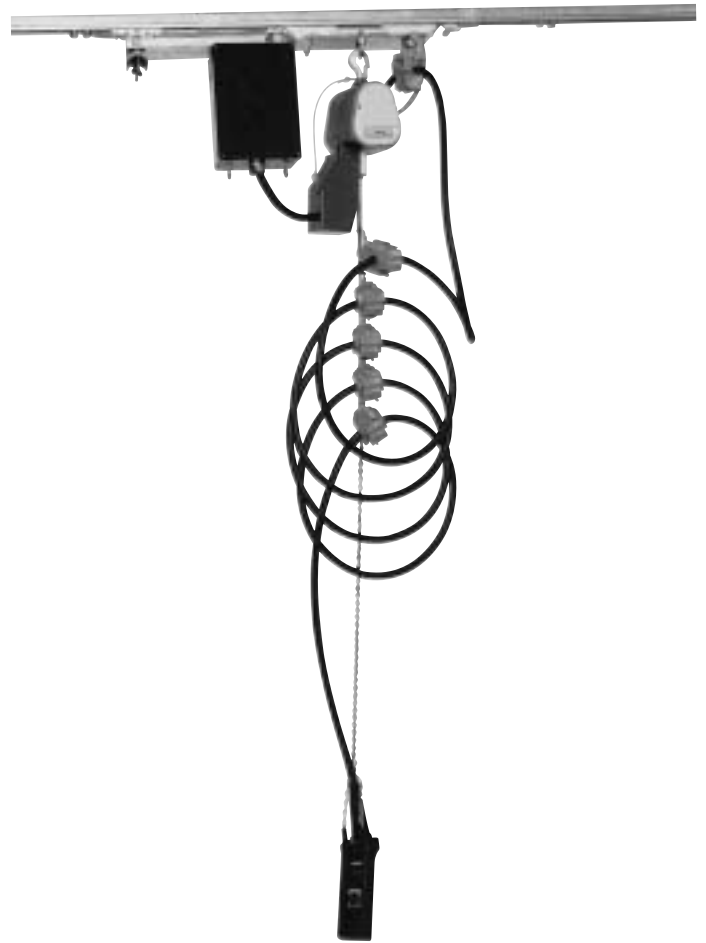

Commissioning and Adjustment of Limit Switch

11. The pushbutton station will lower automatically when pressing key S 2 (down).
12. The cable will form a spiral around the hoist chain and the pushbutton station will be rotating.
13. Once the pushbutton station has reached the lowest position the limit switch S 4 will switch off the hoist motor.
14. The 5 % safety length guarantees a tension relief hanging down of the cable while the hoist chain is carrying the load of the pushbutton station. If this is not the case the limit switch in the chain box would have to be readjusted.
15. When pressing the function key S 1 (up) the pushbutton station will automatically move upward. Limit switch S 3 will switch off the movement.

Wiring diagram for motorized lifting device

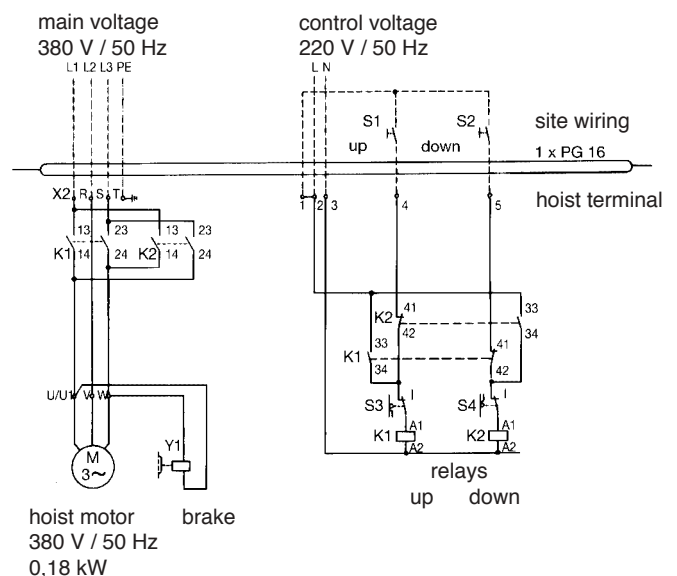

main voltage:	380 V, 50 Hz
control voltage:	220 V, 50 Hz
-----:	site wiring to pushbutton station
S 1 and S 2:	key up/down, part of pushbutton station
S 3 and S 4:	limit switch up/down
K 1 and K 2:	relays up/down

For safety reasons and to completely secure the track joints we do recommend welding together the track and the joint clamps in the upper portion.
Track and hangers at both ends of the system to be horizontally drilled 9 mm Ø and a hex. bolt M 8 x 60 mm, with nut and washer, pushed through to prevent the track from sliding.



S 3 TRACK AND ACCESSORIES

Track

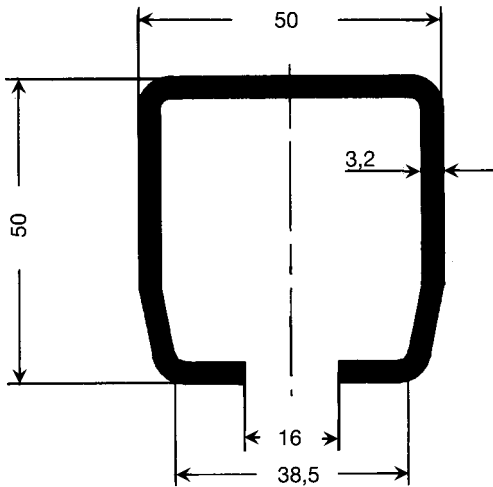

Type	S 3
Order-No. -in 6 m sections	314 126
Order-No. -surcharge for curves	314 048
for carrier type	WST 3
Material	steel, galvanized
Supply length	6 m
Standard support spacing	3 m; in curves 1,5 m
Moment of inertia Jx	16,9 cm ⁴
Section Modulus Wx	6,1 cm ³
Weight	4,050 kg/m

Horizontal Curves w/min. radius of 4 m are ready available. Consult factory for specials.
Support spacing for tracks see diagram on page 47.

Hanger underhung

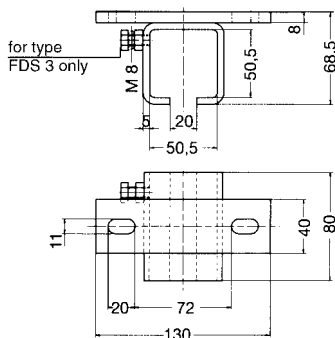

Type	Sliding hanger ADS 3	Fixpoint hanger FDS 3
Order-No.	314 014	314 013
Material	steel, galvanized	
Weight	0,920 kg	0,930 kg

Joint Clamp

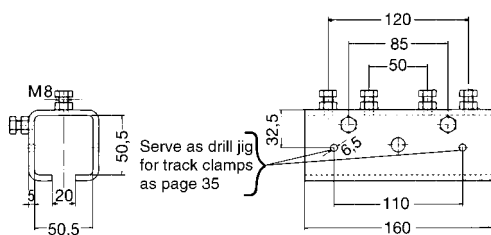

Type	VS 3
Order-No.	314 008
Material	steel, galvanized
Weight	1,250 kg

End Cap

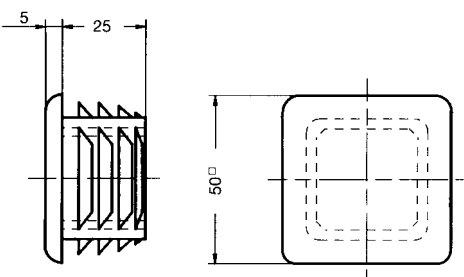

Type	KS 3
Order-No.	314 016
Material	polyethylene
Weight	0,020 kg



S 3 CABLE CARRIERS AND ACCESSORIES

- Steel type -



Engineering Data



Type	WST 3
Wheels	ball bearing sealed against dust and splash water, steel hardened, galvanized or with Polyurethane cover Temperature resistance Lub. grease of wheels: - 30° C to + 125° C Travelling speed: ca. 120 m/min.
Material	Carrier body: steel, galvanized Support saddle: light metal Bumper: Neoprene Hardware: galvanized Temperature resistance: - 30° C to +100° C
Max. cable load	max. 55 kg per carrier
Depth of cable loop	for curves max. 0,3 x track radius; consider tension relief

Cable Carriers for flatrom cable

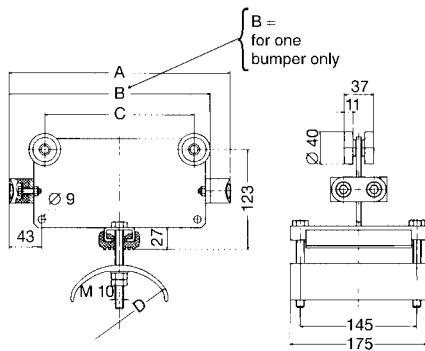

Type *	max. thckn. of individual cable mm	max. clamping capacity in mm height x width	A B C D				Weight kg	Order-No.	Order-No. Polyurethane wheels
			mm						
WST 3 F/175-100	12	30 x 135		175	110	100	2,130	314 018	314 077
WST 3 F/200-100	12	45 x 135	200		110	100	2,240	314 019	314 078
WST 3 F/200-140	14	25 x 135	200		110	140	2,420	314 020	314 079
WST 3 F/250-140	14	50 x 135		250	185	140	2,750	314 021	314 080
WST 3 F/250-170	17	35 x 135		250	185	170	3,480	314 022	314 081
WST 3 F/250-200	20	20 x 135		250	185	200	3,600	314 023	314 082
WST 3 F/275-140	14	60 x 135	275		185	140	2,840	314 024	314 083
WST 3 F/275-170	17	45 x 135	275		185	170	3,570	314 025	314 084
WST 3 F/275-200	20	30 x 135	275		185	200	3,680	314 026	314 085
WST 3 F/325-170	17	70 x 135		325	260	170	3,870	314 027	314 086
WST 3 F/325-200	20	55 x 135		325	260	200	4,020	314 028	314 087
WST 3 F/325-230	23	40 x 135		325	260	230	4,240	314 029	314 088
WST 3 F/350-200	20	70 x 135	350		260	200	4,110	314 030	314 089
WST 3 F/350-230	23	55 x 135	350		260	230	4,330	314 031	314 090

Lead Carriers for flatrom cable

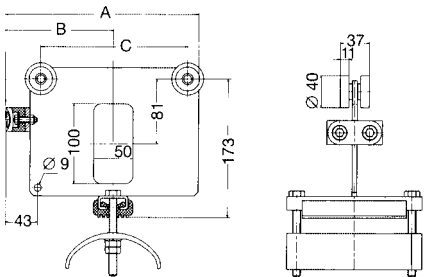

Type *	for Carrier type	A B C			Weight kg	Order-No.	Order-No. Polyurethane wheels
		mm					
MST 3 F/275-100	WST 3 F/175-100	244	138	185	2,720	314 032	314 091
	WST 3 F/200-100						
MST 3 F/275-140	WST 3 F/200-140	244	138	185	2,930	314 033	314 092
	WST 3 F/250-140						
	WST 3 F/275-140						
MST 3 F/275-170	WST 3 F/250-170	244	138	185	3,660	314 034	314 093
	WST 3 F/275-170						
MST 3 F/275-200	WST 3 F/250-200	244	138	185	3,770	314 035	314 094
	WST 3 F/275-200						
MST 3 F/325-170	WST 3 F/325-170	319	175	260	4,220	314 036	314 095
MST 3 F/350-200	WST 3 F/325-200	319	175	260	4,360	314 037	314 096
	WST 3 F/350-200						
MST 3 F/350-230	WST 3 F/325-230	319	175	260	4,580	314 038	314 097
	WST 3 F/350-230						

Track Clamps for flatrom cables

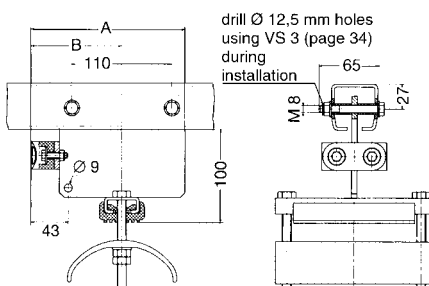

Type	for Carrier type	A B		Weight kg	Order-No.
		mm			
EST 3 F/200-100	WST 3 F/175-100	169	100	1,800	314 039
	WST 3 F/200-100				
EST 3 F/200-140	WST 3 F/200-140	169	100	1,970	314 040
EST 3 F/275-140	WST 3 F/250-140	244	138	2,390	314 041
	WST 3 F/275-140				
EST 3 F/275-170	WST 3 F/250-170	244	138	3,120	314 042
	WST 3 F/275-170				
EST 3 F/275-200	WST 3 F/250-200	244	138	3,240	314 043
	WST 3 F/275-200				
EST 3 F/325-170	WST 3 F/325-170	319	175	3,510	314 044
EST 3 F/350-200	WST 3 F/325-200	319	175	3,660	314 045
	WST 3 F/350-200				
EST 3 F/350-230	WST 3 F/325-230	319	175	3,880	314 046
	WST 3 F/350-230				

* Use suffix-V for Polyurethane wheels; e.g. WST 3 F/175-100-V for Order-No. 314 077.



K 1 TRACK

acid
proof



Extremely corrosive atmospheres (e. g. acid baths, galvanizing plants, sewage treatment plants, chemical plants etc.) require suitable materials.

The K1 track system, designed specifically for such applications, meets these special requirements.

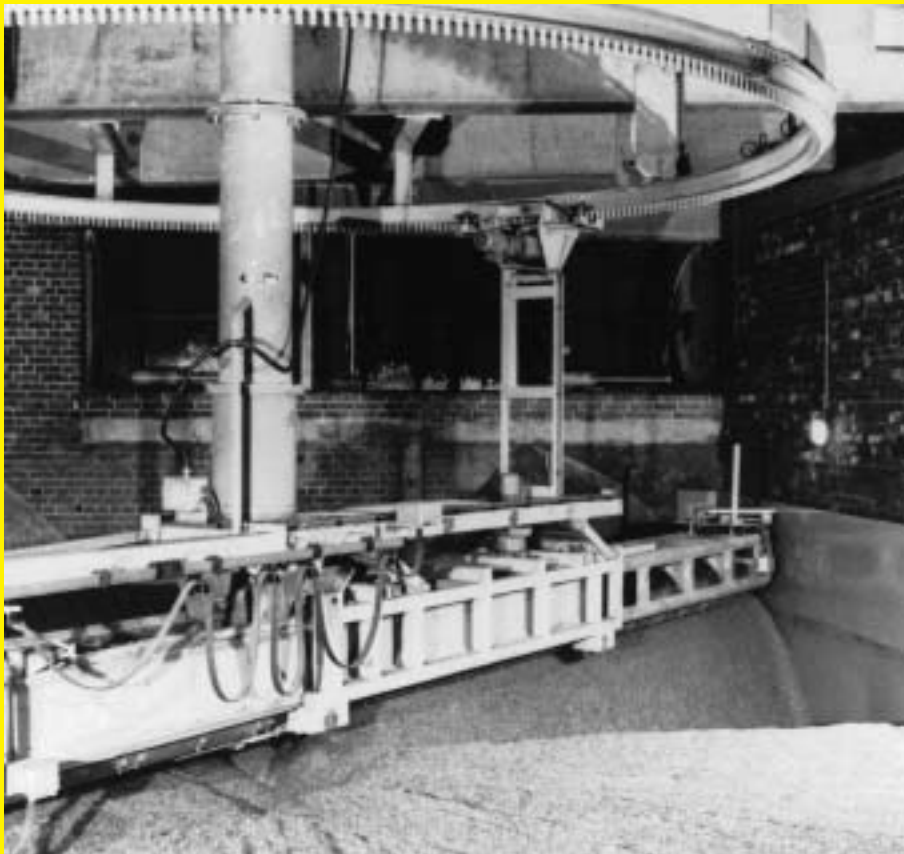

K 1 system in a malt factory

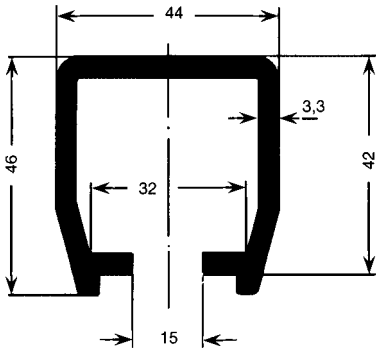

Track

Type	K1	K 1 W
Order-No. in 4 m sections	311 324	311 334
for Carriers type	SK 1 and WK 1	
Material	PVC	PPO
Temperature resistance	- 30° C to + 55° C	- 30° C to + 80° C
Min. bending radius	1,5 m	
Supply length	4 m	
Standard support spacing	1 m, 0,5 m max. in curves	
max. load	25 kg Support distance 1 m	
Moment of inertia Jx	13,18 cm ⁴	
Sections modulus Wx	5,18 cm ³	
Weight	0,740 kg/m	0,570 kg/m

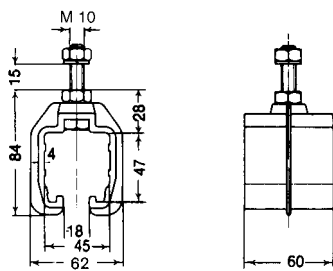

Sliding Hanger

Type	GK 1
Order-No.	311 020
Material	Polyethylene Hardware: stainless steel
max. load	25 kg
Weight	0,110 kg

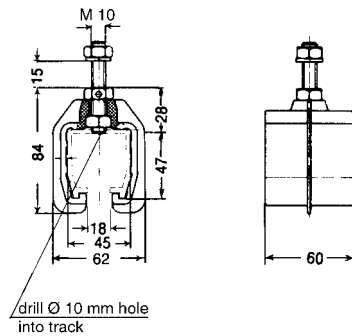

Fixpoint Hanger

Type	FK 1
Order-No.	311 030
Material	Polyethylene Hardware: stainless steel
max. load	25 kg
Weight	0,110 kg

Every installation requires one fixpoint hanger only in the center of the run. With control carriers use one additional each end.

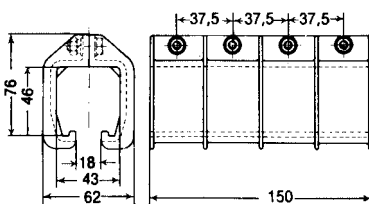

Joint Clamp

Type	VK 1
Order-No.	311 040
Material	Polyethylene Hardware: stainless steel
Weight	0,160 kg

End Cap

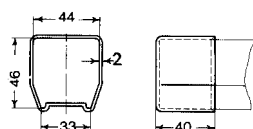

Type	K 1 E
Order-No.	312 170
Material	Polyethylene
Weight	0,010 kg



K 1 CABLE CARRIERS

acid proof



Engineering Data – glider type

Type	SK 1 F
Max. system length	30 m
Material	Carrier body: HP-Polyethylene Support saddle: HP-Polyethylene Hardware: stainless steel Temperature resistance: - 30° C to +80° C
Travelling speed	max. 50 m/min.
Max. load	max. 5 kg per glider

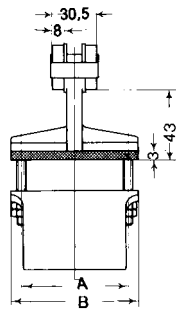
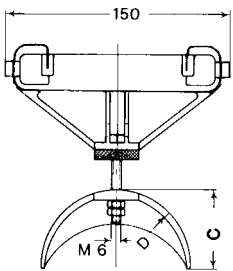

Cable Carrier – glider type – for flatform cable

Type	max. thckn. of individual cable mm	max. clamping capacity mm height x width	A	B	C	D	Weight kg	Order-No.
			mm					
SK 1 F/150	12	25 x 65	71	85	52	100	0,210	311 050

Lead Carrier – glider type – for flatform cable

Type	for Glider type	Weight kg	Order-No.
MSK 1 F/150	SK 1 F/150	0,220	311 060

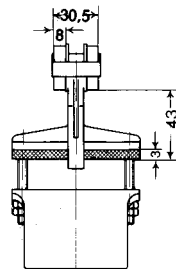
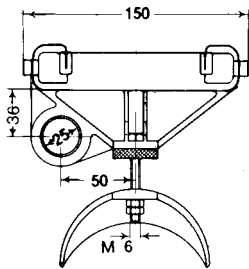

Engineering Data – roller type

Type	WK 1 F
Wheels	Polyethylene rollers on bushed bearings
Travelling Speed	max. 60 m/min.
Material	Carrier body: stainless steel Wheels: Polyethylene Support saddle: stainless steel Hardware: stainless steel Temperature resistance: - 30° C to +80° C
Max. load	max. 10 kg per carrier
Loop depth	for curves max. 0,3 x track radius, consider tension relief



Cable Carrier – roller type – for flatform cable

Type	max. thckn. of individual cable mm	max. clamping capacity mm height x width	A	B	C	D	Weight kg	Order-No.
			mm					
WK 1 F/100 n	8	25 x 65	100	55	25	50	0,420	311 210
WK 1 F/150 n	12	25 x 65	150	95	50	100	0,510	311 180

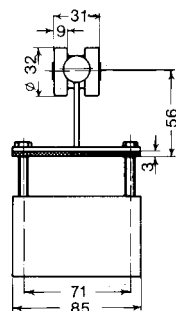
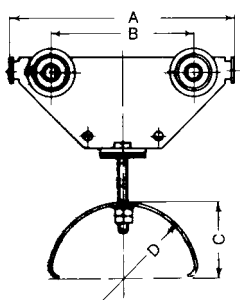



K 1 CARRIERS AND ACCESSORIES

acid proof

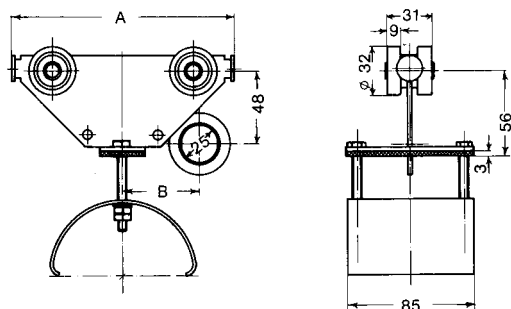

Lead Carriers – roller type – for flatform cables

Type	for Carrier type	A	B	Weight kg	Order-No.
		mm			
MK 1 F/100 n	WK 1 F/100 n	100	45	0,450	311 220
MK 1 F/150 n	WK 1 F/150 n	150	55	0,540	311 190

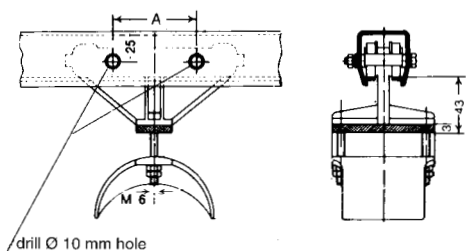

Track Clamps

Type	for Glider and Carrier type	A mm	Weight kg	Order-No.
ESK 1 F/150	SK 1 F/150	70	0,220	311 070
EK 1 F/100 n	WK 1 F/100 n	55	0,370	311 230
EK 1 F/150 n	WK 1 F/150 n	95	0,500	311 200

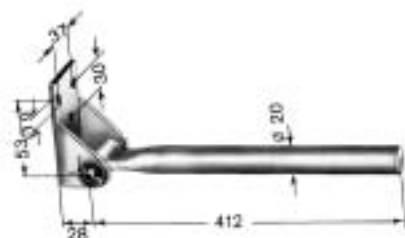

Tow arm

Type	GKM	GKM/K
Material	steel, galvanized	stainless steel
Weight	0,620 kg	0,620 kg
Order-No.	260 350	261 560

Control Carrier

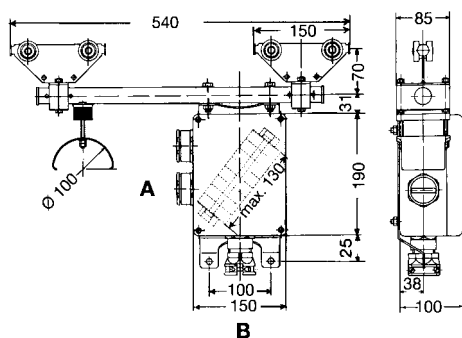

Type *	max. thic kn. of individual cable mm	max. clamping capacity mm height x width	max. carrying capacity kg	Weight kg	Order-No.
ST-K 1	12	25 x 65	20	2,800	311 110

Cable glands and terminal clamps to be ordered separately (see cat. 8L).

Cable glands	max. number A-Side	max. number B-Side	Cable glands	max. number A-Side	max. number B-Side
PG 16	6	2	PG 36	2	1
PG 21	5	2	PG 42	2	–
PG 29	3	1	PG 48	2	–

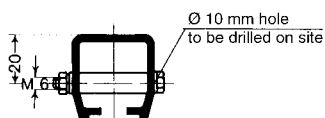

Bumper stop

Type	PK 1
Material	PVC
Hardware	stainless steel
Weight	0,020 kg
Order-No.	311 170

* Control Carrier tracks use one fixpoint hanger each in the center and at both ends of the run. The rest is sliding hangers.



K 1 CABLE CARRIERS AND ACCESSORIES – Steel swivel type –

acid proof

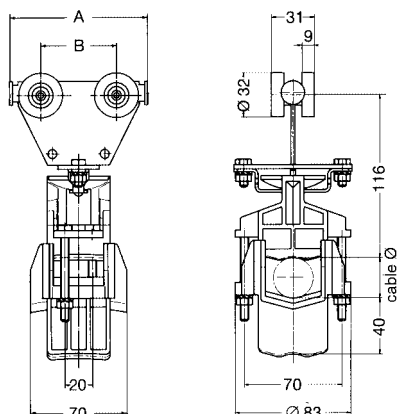

Engineering Data

Type	WK 1 R
Wheels	Polyethylene rollers on bushed bearings
Travelling speed	60 m/min.
Material	Carrier body: stainless steel Wheels: Polyethylene Support saddle: Polypropylene Hardware: stainless steel Temperature resistance: – 10° C to + 80° C
max. cable load	max. 10 kg per carrier
Depth of cable loop	for curves max. 0,3 x track radius, consider tension relief

Cable Carriers for round cables and hoses

Type	Cable Ø	A	B	Weight kg	Order-No.
		mm			
WK 1 R/100	5 mm to 38 mm	100	55	0,420	311 308
WK 1 R/150		150	95	0,470	311 309

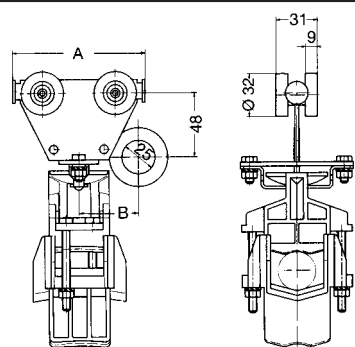

Lead Carriers for round cables and hoses

Type	for Carrier type	A	B	Weight kg	Order-No.
		mm			
MK 1 R/100	WK 1 R/100	100	45	0,450	311 310
MK 1 R/150	WK 1 R/150	150	55	0,500	311 311

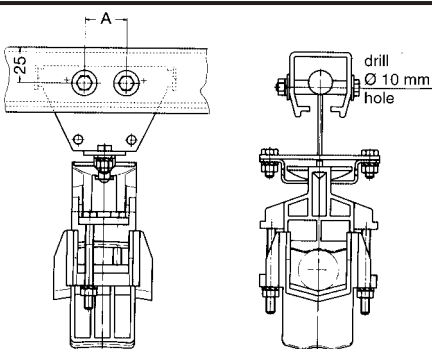

Track Clamps for round cables and hoses

Type	for Carrier type	A mm	Weight kg	Order-No.
EK 1 R/100	WK 1 R/100	55	0,370	311 312
EK 1 R/150	WK 1 R/150	95	0,420	311 313

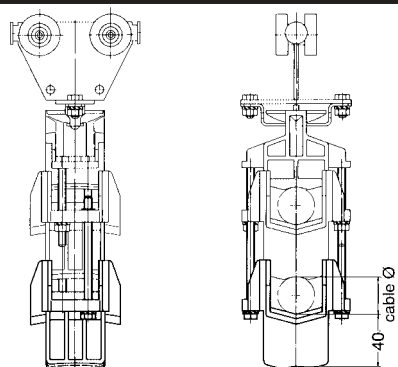

Support saddle for round cables and hoses for additional tiers

Type	for Carrier type	Weight kg	Order-No.
LAR-E	WK 1 R (all types)	0,110	312 532



TENSION RELIEF

Chains for WST 1 and WST 2 carriers

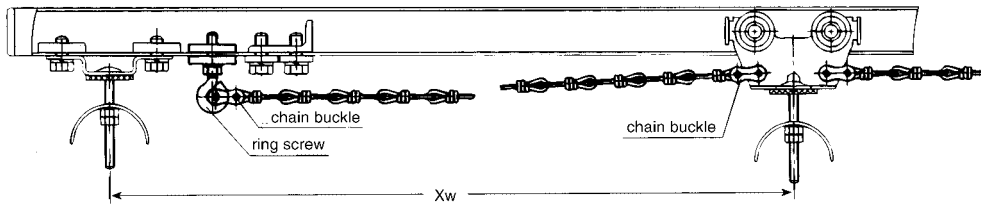

Type	ZEK	ZEK-K 27
Order-No.	360 027	316 434
Material	steel	steel
Wire-Ø mm	1,8	2,5
Link size mm	23	35
Protection	galvanized	galvanized
Weight kg/m	0,075	0,140

Accessories:

Each piece of chain requires: 2 chain buckles type KSS*, Cat.-No. 360 028.
 Each track clamp requires: 1 ring screw type RS 1-2, Cat.-No. 312 827.

How to determine length of chain

$$X_w = \frac{S + SP}{n} \times 1,05$$

X_w = Distance c/c carriers with chain stretched mm
 S = Travel distance mm
 SP = Storage distance in mm
 n = Number of loops

Steel Tow Ropes for WST 3 Carriers

Standard steel rope with fibreglass reinforcing
 Type Z 4 galvanized; Type Z 4 - PVC additionally PVC shrouded complete, cut to suit the application, incl. rope clamps, thimbles and shackles.

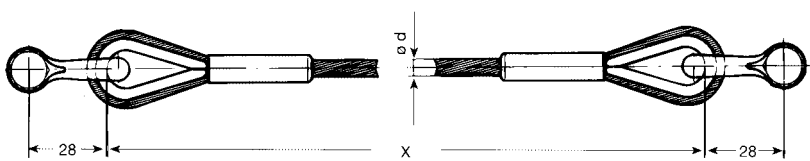

Length of Tow Rope mm	Z 4 d = 6 mm	Z 4-PVC d = 6/8 mm
	Order-No.	
up to 2000	346 372	346 383
2001- 3000	346 373	346 384
3001- 4000	346 374	346 385
4001- 5000	346 375	346 386
5001- 6000	346 376	346 387
6001- 7000	346 377	346 388
7001- 8000	346 378	346 389
8001- 9000	346 379	346 390
9001-10000	346 380	346 391
10001-11000	346 381	346 392
11001-12000	346 382	346 393

Please specify with your order:
 Tow Rope: Type
 Length of tow rope X: mm
 Order-No.:

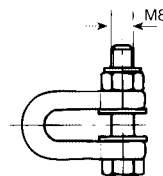

How to determine length of rope

$$X = \frac{S \cdot (f - 0,1) + Z}{n} + 2 Y$$

X = Length of tow rope mm
 S = Travel distance mm
 f = Cable safety factor (e.g. $\geq 1,15$)
 Z = Open space (min. 1 carrier) mm
 n = Number of loops
 Y = Projecting bumper mm (see table)

Bumper projection:	
Carrier Type	Y in mm
WST 3 (1 bumper)	3
WST 3 (2 bumpers)	15

* not suited for WST 2 F/85, WST 2 F/125, WST 2 F/150, WST 2 F/200-100, WST 2 F/200-140, WST 2 F/250-140, WST 2 R/85, WST 2 R/125.



TYPICAL APPLICATIONS AND HOW TO ORDER

- cables & fittings see cat. 8 L -

S 1 Track System (flat cable)

Application: Electric hoist, outdoors with separate supply system for pendant control

Current load:	11 kW
Voltage:	380 V, 50 Hz
Required control cable:	7 x 1,5 mm ²
Travel distance:	28 m
Perm. depth of loops:	1 m
Travel speed:	35 m/min

How to select the correct cable festoon system:

1. Take ampere load from cat. 8 L	22,5 A
2. Select suitable cables (cat. 8 L)	For main current: Neoprene flatform cable 4 x 2,5 mm ² , dimensions: 8,2 x 24 mm For control current: Neoprene flatform cable 8 x 1,5 mm ² , dimensions: 6,4 x 32 mm
3. Select cable carrier, see page 10	WS 1 F/85-PM
4. Cable safety length, see page 48	f = 1,1
5. Determine number of cable loops, diagram page 49	17
6. Determine storage distance, formula page 48 SP = 17 x 85 mm + 85 mm	= min. 1530 mm
7. Determine length of cable, formula page 48 L = (28 m + 1,53 m) x 1,1 = 32,48 m + 2 x 1 m hookup ends	= 35 m
8. Control carrier, see page 18	ST-ST 1/A1

Material to order:	Type	Order-No.
2 x 30 m Track (10 lengths of 6 m)	S1	312 956
2 x 17 Fixpoint hangers *	FAS 1	310 500
2 x 17 Pair of Bolts	M 8 x 25	310 510
2 x 4 Joint clamps	VS 1	310 050
2 x 2 End caps	K 30	360 023
2 x 16 Cable carriers	WS 1 F/85-PM	312 689
1 Lead carrier	MS 1 F/85-PM	312 692
2 x 1 Track clamp	ES 1 F/85-PM	312 693
3 Bumper stops	PS 1-1	312 605
1 Control carrier	ST-ST 1/A1	312 695
c/w:		
7 Terminal clamps	SAK 2,5	330 800
1 Terminal clamp for ground	EK 2,5 NPA	331 283
1 End plate	APPA 2,5	331 278
2 End angles	EWK 1	331 288
A-Side: 1 flat cable gland for 8 x 1,5 mm ²	Pg 36	330 990
1 counter nut	GPg 36	331 314
B-Side: 1 round cable gland for 8 x 1,5 mm ²	Pg 21 K	331 210
1 counter nut	GPg 21	331 312
1 Brake spring	BF 1	310 860
2 flat cable glands for 4 x 2,5 mm ²	Pg 29	330 920
2 counter nuts	GPg 29	331 313
1 flat cable gland for 8 x 1,5 mm ²	Pg 36	330 990
1 counter nut	GPg 36	331 314



S 1 Track System (spiral looped round cable)

Application: Power supply to welding machine

Cable:	2 round cables Ø 25 mm 1 hose Ø 22 mm
Travel distance:	42 m
Perm. depth of loops:	1,7 m
Travel speed:	max. 30 m/min

How to select the correct cable festoon system:

1. Selection of carriers, see page 15	WST 1 R/125
2. Additional support saddles, see page 15	LAR
3. Cable safety length, see page 48	f = 1,2
4. Determine number of cable loops, diagram page 51	15
5. Determine storage distance, formula page 48 SP = 15 x 125 mm + 125 mm	= min. 2000 mm
6. Determine length of cable/hose, formula page 48 L = (42 m + 2 m) x 1,2 = 52,8 m + 2 x 3 m hookup ends	= 59 m

Material to order:	Type	Order-No.
45 m Track (7 lengths of 6 m, 1 length of 3 m)	S 1, 6 m S 1, 3 m	312 956 312 953
2 Fixpoint hangers *	FDS 1	310 430
22 Sliding hangers *	ADS 1	310 370
7 Joint clamps	VS 1	310 050
2 End caps	K 30	360 023
14 Cable carriers	WST 1 R/125	312 493
1 Lead carrier	MST 1 R/125	312 497
1 Track clamp	EST 1 R	312 498
32 Support saddles	LAR	312 500
1 Bumper stop	PS 1	310 300



* Consider permissible track area load (see diagram page 47).



TYPICAL APPLICATIONS AND HOW TO ORDER

- cables & fittings see cat. 8 L -

S 2 Track System (flat cables)

Application: Current supply system for crane trolley indoors

Cables:	2 flatform 4 x 16 mm ² 4 flatform 12 x 2,5 mm ²
Travel distance:	35 m
Perm. depth of loops:	1,8 m
Travel speed:	80 m/min

How to select the correct cable festoon system:

1. Select cable carrier, see page 27	WST 2 F/200
2. Cable safety length, see page 48	f = 1,15
3. Determine number of cable loops, diagram page 50	12
4. Determine storage distance, formula page 48 SP = 12 x 200 mm + 200 mm	= min. 2600 mm
5. Determine length of cable, formula page 48 L = (35 m + 2,6 m) x 1,15 = 43,24 m + 2 x 4 m hookup ends	= 52 m

Material to order:	Type	Order-No.
38 m Track (6 x 6 m, 1 x 2 m)	S 2, 6 m	312 636
	S 2, 2 m	312 632
2 Fixpoint hangers *	FDS 2	315 210
21 Sliding hangers *	ADS 2	315 200
6 Joint clamps	VS 2	315 050
2 End caps	K 40	316 449
11 Cable carriers	WST 2 F/200	316 010
1 Lead carrier	MST 2 F/200	316 060
1 Track clamp	EST 2 F/200	316 110
1 Bumper stop	PS 2 G	315 190
2 x 52 m PVC-flatform cable (N)	H07 VV H6-F 4 G 16	331 362
4 x 52 m PVC-flatform cable (N)	H07 VV H6-F 12 G 2,5	331 358
4 flat cable glands for 4 x 16 mm ²	Pg 42	330 980
4 counter nuts	GPg 42	331 315
8 flat cable glands for 12 x 2,5 mm ²	Pg 48	330 940
8 counter nuts	GPg 48	331 316

K 1 Track System (flat cables)

Application: Current supply system for a malt factory (high humidity)

Cables:	1 flatform 4 x 10 mm ² 3 flatform 8 x 1,5 mm ²
Travel distance:	50 m
Perm. depth of loops:	1 m
Travel speed:	20 m/min

How to select the correct cable festoon system:

1. Select cable carrier, see page 38	WK 1 F/150 n
2. Cable safety length, see page 48	f = 1,1
3. Determine number of cable loops, diagram page 49	29
4. Determine storage distance, formula page 48 SP = 29 x 150 mm + 150 mm	= min. 4,5 m
5. Determine length of cable, formula page 48 L = (50 m + 4,5 m) x 1,1 = 59,95 m + 2 x 2 m connection ends	= 64 m

Material to order:	Type	Order-No.
55 m Track (13 x 4 m, 1 x 3 m)	K 1, 4 m	311 324
	K 1, 3 m	311 323
13 Joint clamps	VK 1	311 040
59 Sliding hangers **	GK 1	311 020
1 Fixpoint hanger **	FK 1	311 030
2 End caps	K 1 E	312 170
28 Cable carriers	WK 1 F/150 n	311 180
1 Lead carrier	MK 1 F/150 n	311 190
1 Tow arm	GKM/K	311 301
1 Track clamp	EK 1 F/150 n	311 200
64 m PVC-flatform cable (N)	H07 VV H2-F 4 G 10	331 361
3 x 64 m PVC-flatform cable (N)	H07 VV H2-F 8 G 1,5	331 354



INSTALLATION INFORMATION

Box-Tracks

1. Mount the track in parallel to the runway of equipment, the side clearance to be sufficient to avoid interference with swinging cable carriers/cables.

2. Support track with hangers.

Support spacing see diagram page 47.

Support spacing K 1, K 1 W max. 1 m

Support spacing in curves:

S 1 A, S 1, S 1-E max. 1 m
 S 2, S 2-E max. 1,25 m
 S 3 max. 1,5 m
 K 1, K 1 W max. 0,5 m

3. The track must be anchored by two fixpoint hangers in the center of the run. With fixpoint hangers for the systems S 1, S 2 and S 3 set and counter the grub-screw. The K 1 system fixpoint hanger requires a boring \varnothing 10 mm at the top of the track for inserting and locking the M 10 bolt. Use sliding hangers towards both ends.

Installations up to 30 m length may use only the tight clamping version of hangers.

S 1, S 2 and S 3 tracks to serve as control carrier runways must always use fixpoint hangers only. K 1 tracks in conjunction with control carriers use 1 fixpoint hanger in the center and at both ends, the rest is sliding hangers.

4. Connect track sections with joint clamps. Center fit and proper alignment is important.

S 2 control carrier tracks use VS 2-F lock type joints.

5. The ends of the track are closed by end caps after all carriers inserted.

Cable Carriers

Cable carrier WS 1, WST 1, WS 2, WST 2 and WST 3

1. The system must be installed in the following order:
 Lead carrier
 Cable carriers
 Bumper stop (only S 1 and S 2 systems)
 Track clamp
 End cap

For S 1 and S 2

Tighten bolts on track clamp and bumper stop.

For S 3

For anchor track clamp drill 2 holes 12,5 mm \varnothing and insert the 2 bolts (use drill-jig VS 3).

3. Connect lead carrier to equipment with an outrigger-tube \varnothing 30 mm for S 1 and S 2, \varnothing 40 mm for S 3 installations. This tow arm (by others) should fit centrally into the rectangular box of the lead carrier. Make sure that there is sufficient storage space for carriers between track clamp and lead carrier.

4. In case of control carriers use a bumper stop opposite of the track clamp. S 1 and S 2 bumpers to be bolted, K 1 bumpers require a horizontal boring \varnothing 10 mm (20 mm below top of track) for attachment.

For safety reasons and to completely secure the track joints we do recommend welding together the track and the joint clamps in the upper portion or use VS 2-F lock type joints for S 2 tracks. Track and hangers at both ends of the system to be horizontally drilled 9 mm \varnothing and a hex. bolt M 8 x 60 mm, pushed through and secured with nut and washer to prevent the track from sliding.

5. When installing the cables make sure the cable length L (storage distance + max. working travel x approx. 1,1 – 1,2) is equally distributed between the carriers; start from lead carrier or from track clamp and consider hookup cable lengths to input junction box and to the equipment. Secure cables on carriers with compression bolts and lock nuts.

6. Make test runs.

Installation information for control carriers with motorized lifting device see pages 32 and 33.

Glider SK 1 and Carrier WK 1

1. The system must be installed in the following order:

Lead carrier
 Cable carriers
 Track clamp

2. Install track clamp by drilling 2 holes 10 mm \varnothing through K 1 housing and insert the 2 bolts.

Type	A mm
ESK 1/150	70
EK 1/F100 n	30
EK 1/F150 n	70

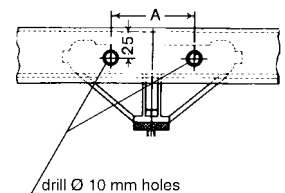

3. Connect lead carrier to equipment by tow arm GKM. The arm should fit centrally into hole of lead carrier, allowing free vertical movement.



SYSTEM LAYOUT

Engineering Data

Cable Specification

Travel distance	S =	m	Number of Cables	Number & Size of Conductors	Cable Type		Weight kg/m	
	Travel speed	V =			m/min	Cable OD Ø mm Round Cable		Width x Thickness Platform Cable
Acceleration	a =	m/s ²						
Loop depth	h =	m						
Storage distance	SP =	m						
Open space	Z =	m						
Cable safety factor	f =							
Number of loops	n =							
Cable carrier	Type							
Length of carrier	l =	m						
Diameter of support saddle	D =	m						
Weight of carrier	Gw =	kg						
Track	Type							
Weight of track	Gs =	kg/m	Total Weight of all cables per meter G _L =					

1. Number of loops (see diagram or formula)

$n = \frac{f \times S}{2h - f \times l + 1,254 D} = \frac{x}{2x - x + 1,254 x} =$		determined
---	--	------------

2. Loop depth (see diagram or formula)

$h = \frac{f}{2} \left(\frac{S}{n} + l \right) - 0,627 \times D = \frac{\quad}{2} \left(\frac{\quad}{\quad} + \quad \right) - 0,627 \times$		m
---	--	---

3. Storage distance (center track clamp to center lead carrier)

$SP = n \times l + Z = \quad \times \quad + \quad =$		m
--	--	---

4. Cable length

Cable length w/o hookup ends $L = (S + SP) \times f = (\quad + \quad) \times$		m
Hookup length – track clamp side	LE =	m
Hookup length – lead carrier side	LM =	m
Total cable length	L total =	m

5. Cable weight per carrier

$GLW = \frac{L}{n} \times GL = \quad \times$		kg
--	--	----

6. Load on track per meter

$GM = \frac{GLW + GW}{l} + Gs = \quad + \quad =$		kg/m
--	--	------

7. Support spacing for track

see diagram page 47	Support spacing l _A =	m
---------------------	----------------------------------	---



SUPPORT SPACING FOR BOX TRACKS

S 1 A – S 1 – S 1 E – S 2 – S 2 E – S 3

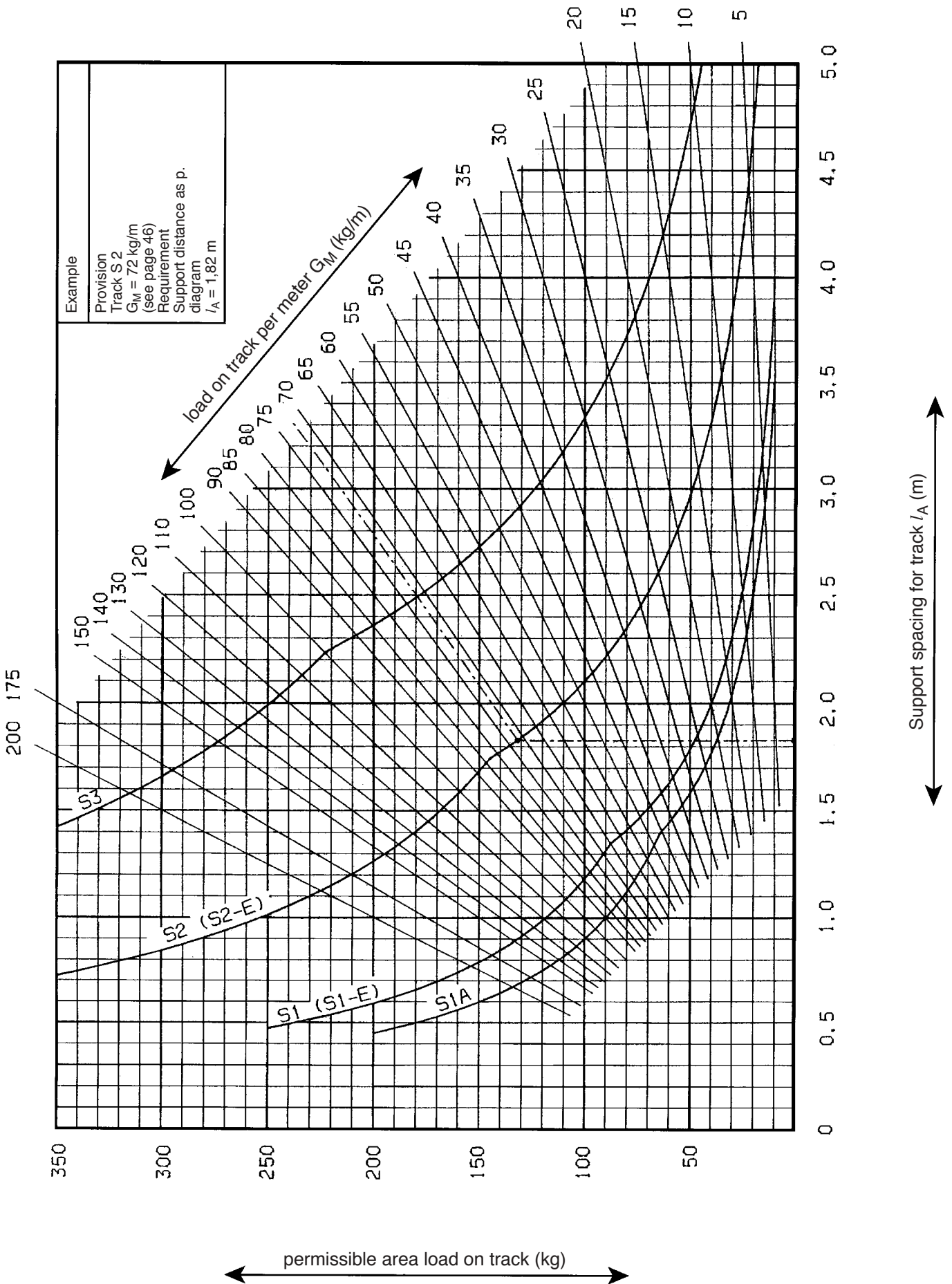



HOW TO DETERMINE Number and Depth of Loops, Storage Distance, Cable Length, Number of Carriers

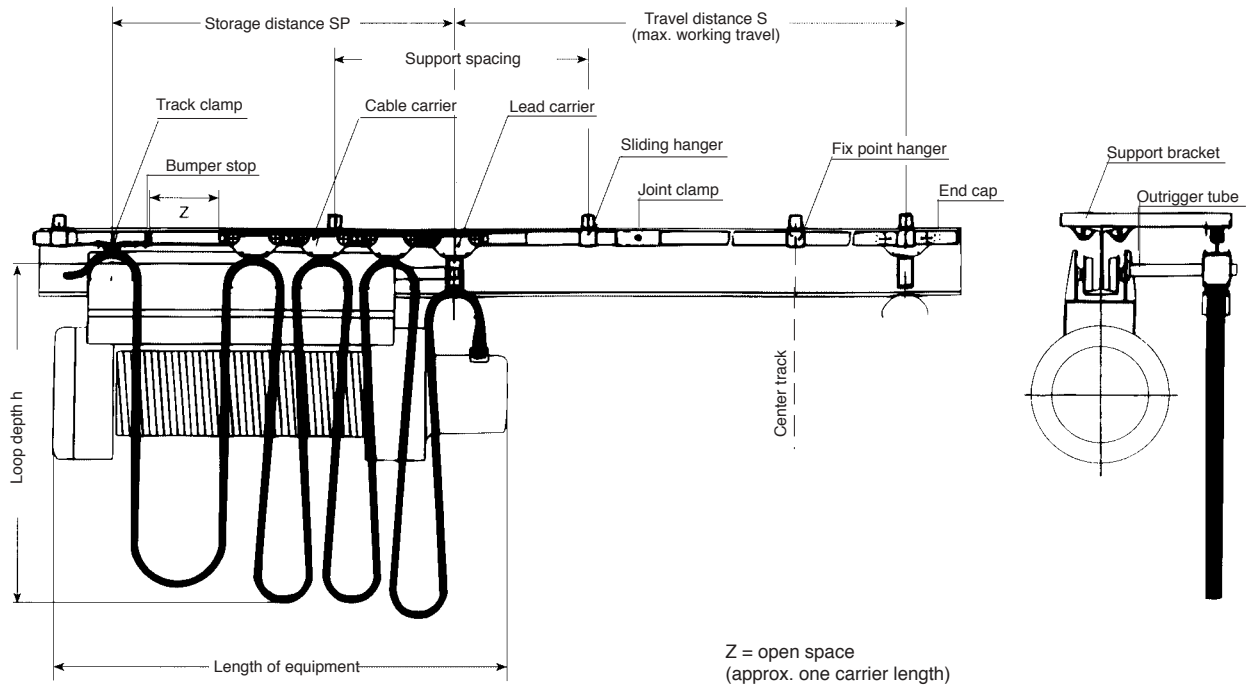

Cable Safety Length Directions

Travel Speed	cable loop depth	safety factor
up to 35 m/min	more than 0,3 m	f = 1,1
up to 50 m/min	up to 0,8 m	f = 1,15
up to 50 m/min	more than 0,8 m	f = 1,1
up to 80 m/min	up to 0,8 m	f = 1,2
up to 80 m/min	more than 0,8 m	f = 1,15
for spiral looped round cable		f = 1,2

For higher speed factors please consult factory.

Number of loops

$$n = \frac{f \times S}{2h - f \times l + 1,254 D}$$

Cable loop depth

$$h = \frac{f}{2} \left(\frac{S}{n} + l \right) - 0,627 \times D$$

Storage distance

$$SP = n \times l + Z$$

Cable length

(c/c track clamp – lead carrier without hookup ends)

$$L = (S + SP) \times f$$

Number of Carriers

(without lead carrier and track clamp)

$$= n - 1$$

- S = Travel distance (m)
- h = Cable loop depth (m)
- SP = Storage distance (m)
- Z = Open space (m)
(min. one carrier length)
- n = Number of loops
- l = Length of carrier (m)
- D = Diameter of support saddle (m)
- f = Cable length safety factor



CABLE LOOPS

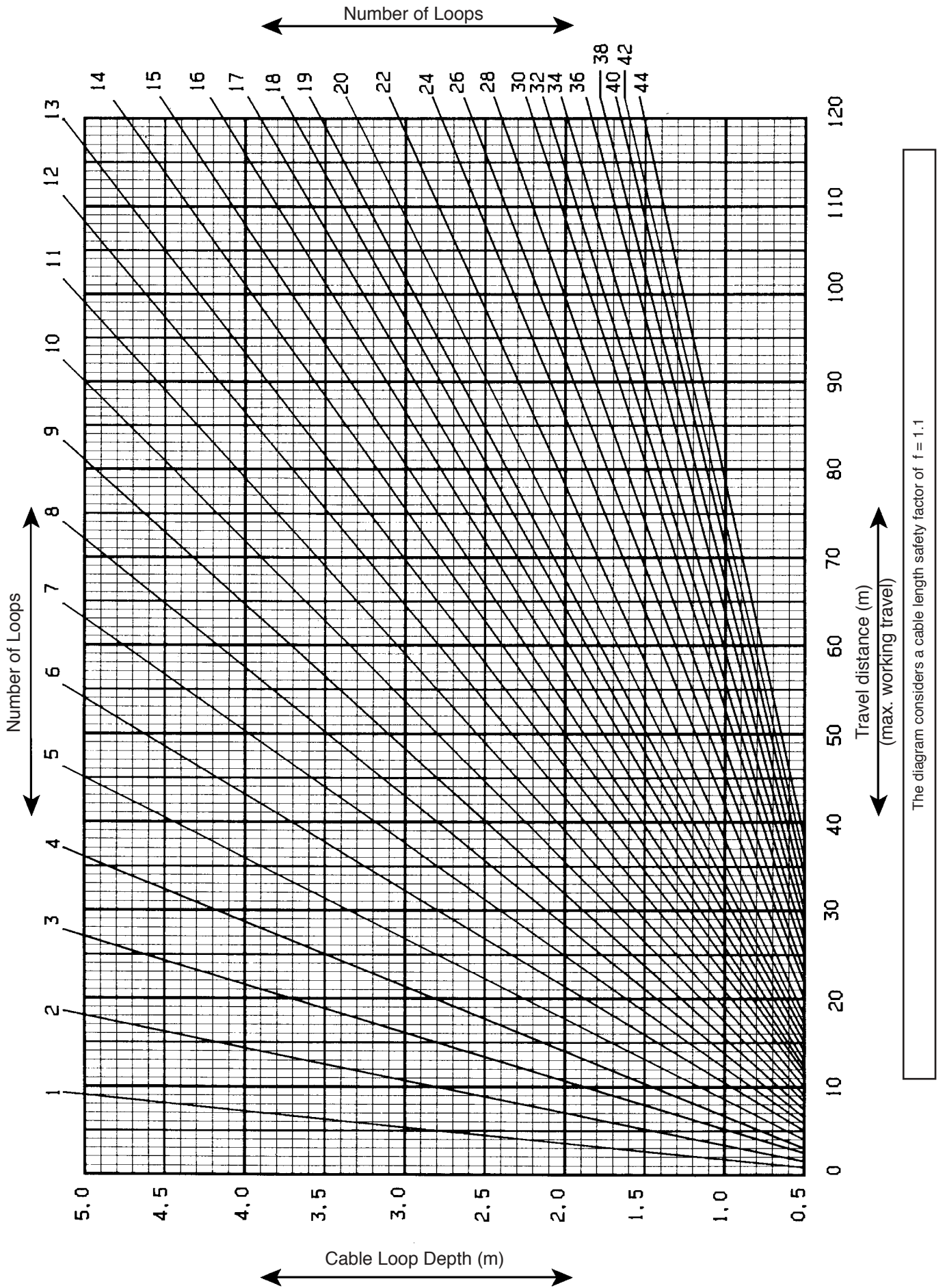

The diagram considers a cable length safety factor of $f = 1.1$



CABLE LOOPS

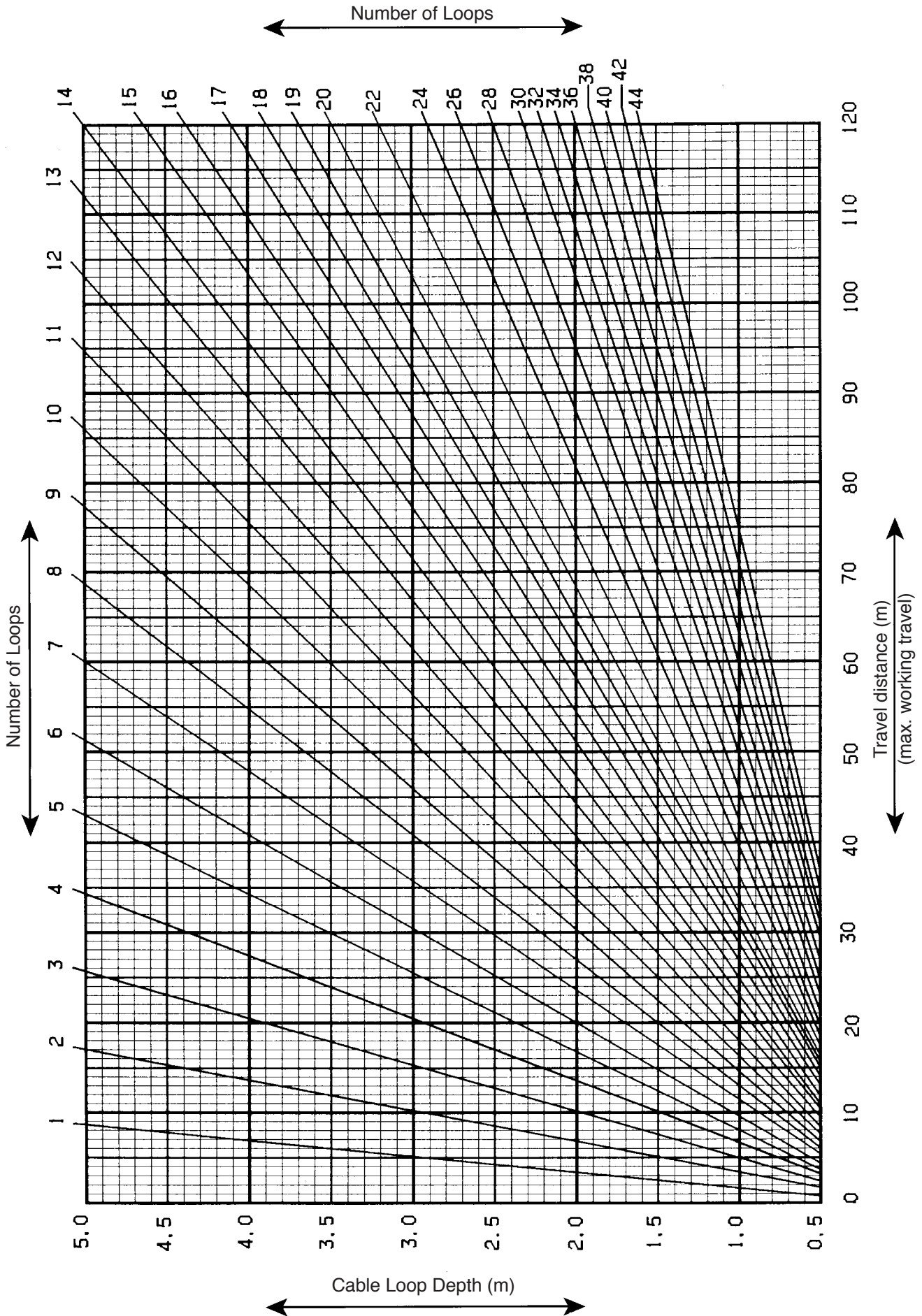

The diagram considers a cable length safety factor of $f = 1.15$



CABLE LOOPS

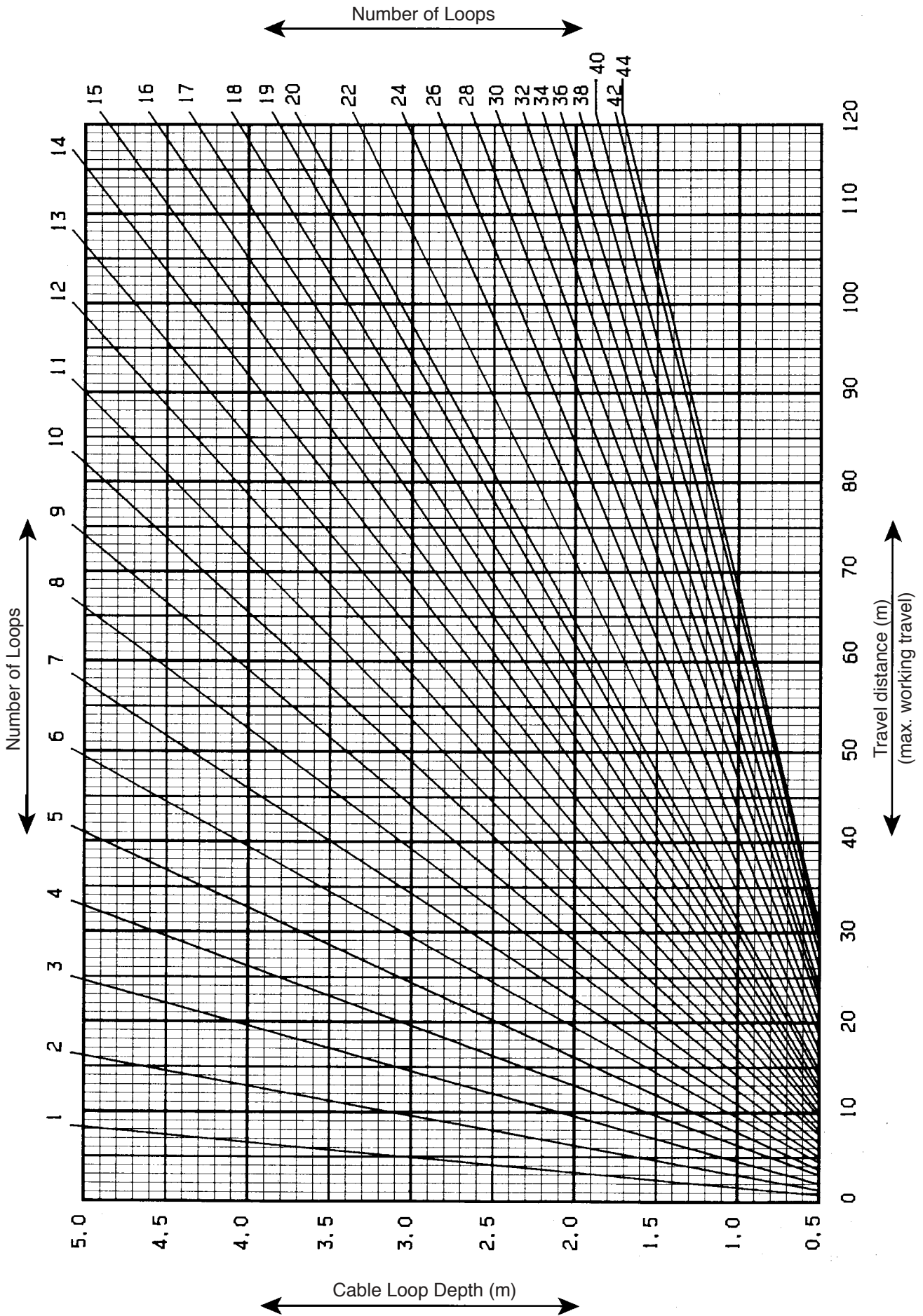

The diagram considers a cable length safety factor of $f = 1.2$