





Our product range includes:

- Multi-axis controller, Double-handle controller, Control switch (Masterswitch), Gear Limit switch for hoisting-, electro-hydraulic application-, material-handling technology and remote control
- Complete crane control unit, portable control unit, pedant control unit, including wiring for all types of cranes and vehicles
- Control pedestal, controllers for offshore application and nautical control devices (ship-drive)
- Pedal controller for welding machine control and speed control
- Master controller for rolling stock
- Displays for forklift and construction machinery
- Proportional control electronic for solenoid valves
- Control electronic with digital and analog outputs matching our controllers
- Control electronic with Profi-Bus interface or CAN-Bus interface matching our controllers (input/output cards)
- DC-contact, signal cam controller for high voltage systems
- Customised solutions for operating units for any type of machinery and vehicles



Our supplies are made in accordance with the "General Conditions of Supply and Delivery for products and services of the electrical and electronic industry" of the German Electrical and Electronic Manufacturers' Association (ZVEI).

Please note additional:

Our catalog prices do not include value added tax, which is added separately.

The prices are ex-works in Leingarten excluding packaging. Packaging is charged at cost and cannot be returned. Our gross prices apply for orders below EURO 75,-. There is a minimum charge of EURO 25,-. Where possible, small orders should be combined.

We are entitled to charge any handling and production costs resulting from modifications of the order caused by the customer (both technical modifications and noncompliance of dead lines).

Payment may be made within 30 days without discount.

These conditions of payment shall be deemed to apply on receipt of our written order confirmation.

All delivery goods remain our sole and absolute property until paid for in full.

The **delivery period** commences only when all technical details have been clarified. Unforeseen circumstances justify an appropriate extension of the delivery period. All documents such as drawings, dimensional drawings, circuit diagrams, etc., are non-binding. We reserve the right to make any changes necessary, in particular technical changes.

Court venue will be exclusively 74072 Heilbronn, Federal Republic of Germany.

 **Warning**

Hazardous voltages are present on specific parts in this electrical device during operation.

Only qualified personal, paying attention to the relevant safety precautions, should install, maintain, modify or fit accessories to the controller. Non-observance of this warning can result in death, severe personal injury or substantial property damage.

Hausanschrift/office:

W. Gessmann GmbH
Eppinger Straße 221
D-74211 Leingarten

UST.Id.Nr.:

DE 145786508

Telefon/phone:

(+49) 0 71 31 - 40 67-0

Fax: Vertrieb/sales:

(+49) 0 71 31 - 40 67 10

E-mail:

gessmann@gessmann.com

Internet:

www.gessmann.com

MWSt. 65205/74401

Finanzamt Heilbronn

Banken/banks:

Baden-Württembergische Bank Heilbronn (BLZ 620 300 50) 70 49 52 9600
SWIFT-Code: BW BK DE 6S 620 · IBAN-Code: DE 23 620 300 50 7049529600
Deutsche Bank Heilbronn (BLZ 620 700 81) account No. 01 94 605
SWIFT-Code: DEUT DE SS 620 · IBAN-Code: DE 14 620 700 81 0019460500
Kreissparkasse Heilbronn (BLZ 620 500 00) account No. 4776
SWIFT-Code: HE IS DE 66 · IBAN-Code: DE 22 620 500 000 00 0004776

**Handelsregister/
commercial register:**
Stuttgart HRB 100312
**Geschäftsführer/
manager:**
Gerhard Häußermann
Alwin Ehrensperger



Pos.		Part No.	Type	Page	
1	Multi-axis controller	5100...	V 6	1/100	
		5102...	VV 6	1/102	
		5104...	VA 6 Ex	1/104	
		510X...	VVB 6	1/106	
		510X...	VVC 6	1/108	
		5110...	V 11	1/110	
		5120...	V 5	1/120	
		5122...	VV 5	1/122	
		513...	V 8/VV 8	1/130	
		513...	V 85/VV 85	1/132	
		5145...	V 25	1/134	
		5140...	V 10	1/140	
		5142...	V 14	1/142	
		5144...	V 20	1/144	
		5146...	V 21	1/146	
		5150...	V 3	1/150	
		5152...	V 18	1/152	
	Double-handle controller	5160...	D/DD 64	1/160	
		5162...	D 8	1/162	
		5164...	D 3	1/164	
		5180...	S 1	1/180	
		5214...	S 14	1/188	
	Single-axis controller	5200...	S 2/SS 2	1/200	
		5202...	S 21/SS 21	1/202	
		5204...	S 22/SS 22	1/204	
		5208...	S 23	1/208	
		5212...	S 3	1/212	
		5216...	S 6	1/216	
		5220...	N 6	1/220	
	Control-switch Potentiometer/Encoder e.t.c. Operator handles Palm grip			1/240	
		5284...	B 1	1/280	
		5285...	B 2	1/285	
		5286...	B 3	1/286	
		5288...	B 4	1/288	
		5289...	B 5	1/289	
		5290...	B 6	1/290	
		5292...	B 7/8	1/292	
		5294...	B 9	1/294	
		5296...	B 10	1/296	
		5297...	B14/15	1/300	
		5298...	B 20	1/310	
				1/350	
				1/360	
		2	Crane control unit		KST 3
				KST 4	2/040
				KST 5	2/050
				KST 6	2/060
	KST 7			2/070	
	KST 75			2/072	
	KST 8			2/080	
	KST 85			2/082	
	KST 9			2/090	
	KST 10			2/100	
	KST 15			2/102	
	KST 18			2/108	
Driver's seat				KFS 2	2/130
				KFS 4	2/132
				KFS 6	2/134
			KFS 7	2/136	
			KFS 8	2/138	
			KFS 9	2/140	
			KFS 10	2/142	
Portable control unit			TS 1	2/150	
			TS 2	2/152	
Control pedestal for offshore			U 22/32	2/160	
		U 23/23	2/162		
		U 25/32	2/164		
Pedant control unit		HT 1/2	2/170		
3	Pedal-controller		P 7/PP 7	3/100	
			P 8/PP 8	3/101	
			P 10/P 11	3/102	
			P 12	3/103	
			GE 1	3/200	
			KVS	3/300	
			SO/SS	3/400	
			NU 1	3/402	
			NU 2	3/404	
			NU 3	3/406	
			ES/43	3/502	
	Gear limit switch Copy-cam controller DC-contact Signal-cam controller		ES/61	3/504	
			E	3/510	
			EPB	3/520	
			ECB	3/530	
			EB/49	3/531	
4	Spare parts (please order separately)			4/100	
5	Description data			5/001	
	Technical data			5/100	
	Representatives / another thing			5/900	



Pos.	V 61	V 61.1	V 62	V 64	V 64.1	Type expansion	Weight gramm	Type	Price EURO
1									
2							960	V 61	
3							980	V 61.1	
4							980	V 62	
5							1010	V 64	
7.1	Multi-axis controller left		(dir. 1-2, 3-4)					L	
7.2	Multi-axis controller right		(dir. 5-6, 7-8)					R	
10	Gate cross-shaped		(prohibits diagonal shifting)				60	P	
11	Gate special-shaped		(e.g. H-gate)				60	PX	
20	Control-handle with knob solid							M	
21	Control-handle with latch for mechanical zero interlock							MP	
21.1	by lifting						50	MN	
21.2	by lifting, interlocking the gate or the joint bracket						60		
21.3	by pushing down						50		
21.4	Mechanical zero interlock with command devices see catalog 1/282								
22	Control-handle with dead man's button 1 NO						100	T	
23	Control-handle with signal button 1 NO						100	H	
24	Control-handle with push button 1 NO						110	D	
25	Control-handle with flat push button 1 NO						110	DV	
26	Control-handle with palm grip B 1						40	B 1	
27	Control-handle with palm grip B 1 with push button top 1 NO						60	B 1T	
28	Control-handle long or short								
28.1			-40 mm					S3	
28.2			-20 mm					S5	
28.3			+20 mm					S8	
29	More knobs, grips and T-grips with and without signal devices see catalog 1/280...								
30	Masterswitch (contact set) switching sequenc 4-0-4					No. of contacts	2	01	
31							4	02	
32	Direction 1-2 and 3-4 each 1 masterswitch						6	03	
33	Switching program according contact-arrangement MS... see catalog 5/001					A...	8	04	
34	or to your contact-arrangement						10	05	
35							12	06	
36	Switching sequence 5-0-5 or 6-0-6								
37	Micro changeover contact (MZT 1) positive opening						2	Z	
38	Spring return in 0-position (for each direction)							R	
39	Friction brake adjustable (for each direction)								
40	Potentiometer e.t.c. each masterswitch with mounted Wire-wound potentiometer T 130, with centre tap, 1,5 Watt wiper current max. 10 mA resistance 2 x 0,5k \geq P021, 2 x 1k \geq P022, 2 x 2k \geq P023, 2 x 5k \geq P024, 2 x 10k \geq P025					...P02 \square		P	
41	Prepared for mounting potentiometer shaft 6 mm adjusting-angle 2 x 150°							(P)	
42	Prepared for mounting potentiometer e.t.c. adjusting-angle variable							(P)	
43	more Potentiometer e.t.c. see catalog 1/240...					C..., P...			
50	Steel sheet housing B 200 masterswitch max. size 04						1300	B	
51	Steel sheet housing B 230 x 340 masterswitch max. size 06						1500	B	
52	More housing see catalog 1/350								
60	Indicating labels not engraved with 2 or 4 arrows								
61	Engraving, each 10 characters								
70	Command and indicating devices see catalog 1/360								

description of one axis is enough, if both axes are identical, eg.: A05 P024 + A05 P024 => A05 P024

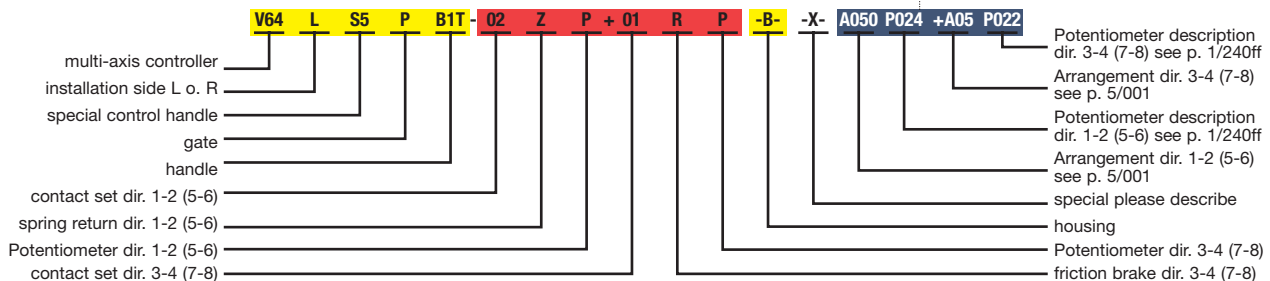

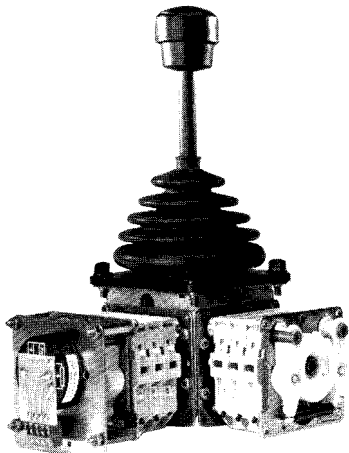

Type V62L-03ZP+03Z-...

The multi-axis controller V 6 is a rugged switching device according IEC 947-5-1 EN 60947 DIN VDE 0660-200 for hoisting applications. The modular design enables the switching device to be used universally. The V 6 is resistant to oil, maritime climate, ozone and UV radiation.

Contact complement 2 A 250 V AC 15 res. 1 A 24 V DC 13 (standard) or 4 A 250 V AC 15 (special)

Mechanical life 10 million (operating cycles)
Permissible ambient temperature Operation -40° C to +60° C
Storage -50° C to +80° C

Climate resistance
Damp heat constant DIN IEC 68 part 2-3
Damp heat cyclic DIN IEC 68 part 2-30
Degree of protection front IP 54 IEC 529 DIN 40050
Technical data see catalog 5/100
Description data see catalog 5/002

Spindle block with schematic representation of the master controller installation and deflection directions.
Version shown for left-hand side installation (right-hand side installation is mirror image).

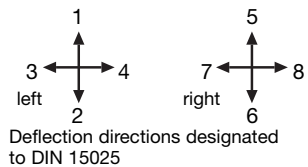

Pos.	V 61	V 61.1	V 62	V 64	V 64.1	Type expansion	Weight gramm	Type	Price EURO
1							960	V 61	
2							980	V 61.1	
3							980	V 62	
4							1010	V 64	
5							960	V 64.1	
7.1	Multi-axis controller left		(dir. 1-2, 3-4)					L	
7.2	Multi-axis controller right		(dir. 5-6, 7-8)					R	
10	Gate cross-shaped		(prohibits diagonal shifting)				60	P	
11	Gate special-shaped		(e.g. H-gate)				60	PX	
20	Control-handle with knob solid								
21	Control-handle with latch for mechanical zero interlock								
21.1	by lifting						50	M	
21.2	by lifting, interlocking the gate or the joint bracket						60	MP	
21.3	by pushing down						50	MN	
21.4	Mechanical zero interlock with command devices see catalog 1/282								
22	Control-handle with dead man's button 1 NO						100	T	
23	Control-handle with signal button 1 NO						100	H	
24	Control-handle with push button 1 NO						110	D	
25	Control-handle with flat push button 1 NO						110	DV	
26	Control-handle with palm grip B 1						40	B 1	
27	Control-handle with palm grip B 1 with push button top 1 NO						60	B 1T	
28	Control-handle long or short								
28.1			-40 mm					S3	
28.2			-20 mm					S5	
28.3			+20 mm					S8	
29	More knobs, grips and T-grips with and without signal devices see catalog 1/280...								
30	Masterswitch (contact set) switching sequenc 4-0-4					No. of contacts 2	290	01	
31						4	350	02	
32	Direction 1-2 and 3-4 each 1 masterswitch					6	410	03	
33	Switching program according contact-arrangement MS... see catalog 5/001				A...	8	470	04	
34	or to your contact-arrangement					10	530	05	
35						12	590	06	
36	Switching sequence 5-0-5 or 6-0-6								
37	Micro changeover contact (MZT 1) positive opening					2			
38	Spring return in 0-position (for each direction)						110	Z	
39	Friction brake adjustable (for each direction)						30	R	
40	Potentiometer e.t.c. each masterswitch with mounted Wire-wound potentiometer T 130, with centre tap, 1,5 Watt wiper current max. 10 mA resistance 2 x 0,5k \pm P021, 2 x 1k \pm P022, 2 x 2k \pm P023, 2 x 5k \pm P024, 2 x 10k \pm P025				...P02 \square		70	P	
41	Prepared for mounting potentiometer shaft 6 mm adjusting-angle 2 x 150°							(P)	
42	Prepared for mounting potentiometer e.t.c. adjusting-angle variable.							(P)	
43	more Potentiometer e.t.c. see catalog 1/240...				C..., P...				
50	Steel sheet housing B 200 masterswitch max. size 04						1300	B	
51	Steel sheet housing B 230 x 340 masterswitch max. size 06						1500	B	
52	More housing see catalog 1/350								
60	Indicating labels not engraved with 2 or 4 arrows								
61	Engraving, each 10 characters								
70	Command and indicating devices see catalog 1/360								



T = dead man's button
H = signal button
M = latch for mechanical zero interlock

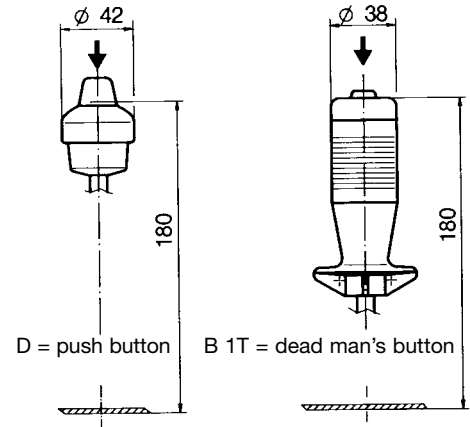
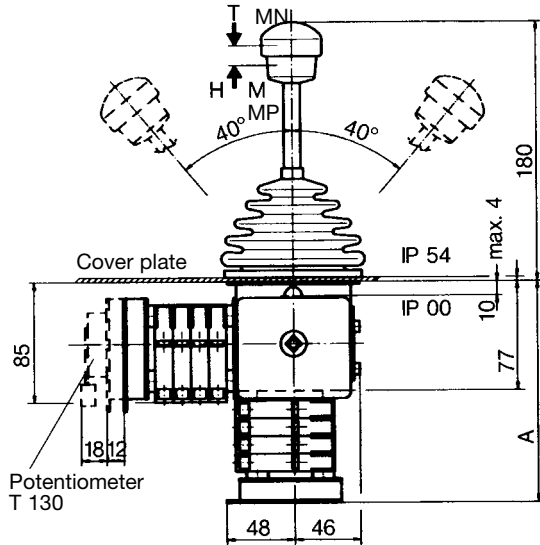

Type	No. of contacts	Dimension A	Dimension B
01	2	119	82
02	4	131	94
03	6	144	107
04	8	156	119
05	10	169	132
06	12	181	144

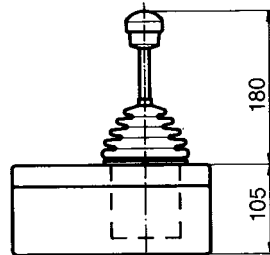
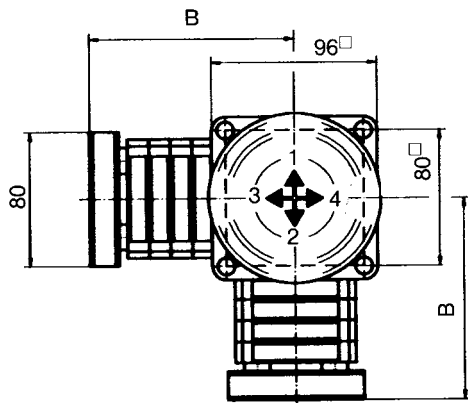

Steel sheet housing

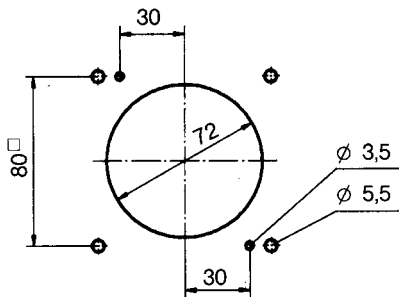

Hole pattern

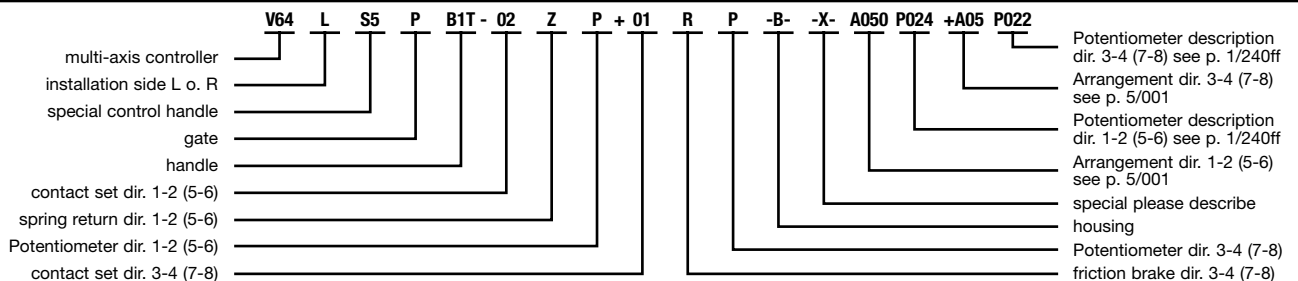
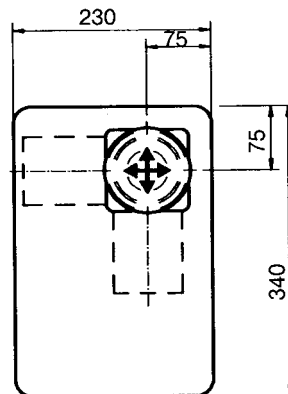

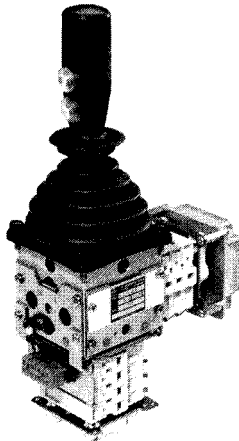

Type V64LB12D-04Z+03ZC-...

The multi-axis controller VV 6 is a rugged switching device according IEC 947-5-1 EN 60947 DIN VDE 0660-200 for hoisting applications. The modular design enables the switching device to be used universally. The VV 6 is resistant to oil, maritime climate, ozone and UV radiation.

Contact complement 2 A 250 V AC 15 res. 1 A 24 V DC 13 (standard) or 4 A 250 V AC 15 (special)

Mechanical life 20 million (operating cycles)
Permissible ambient temperature Operation -40° C to +60° C
Storage -50° C to +80° C

Climate resistance
Damp heat constant DIN IEC 68 part 2-3
Damp heat cyclic DIN IEC 68 part 2-30
Degree of protection front IP 54 IEC 529 DIN 40050
Technical data see catalog 5/100
Description data see catalog 5/002

Spindle block with schematic representation of the master controller installation and deflection directions. Version shown for left-hand side installation (right-hand side installation is mirror image).

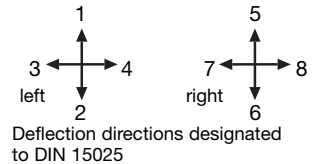

Pos.	VV 61	VV 61.1	VV 62	VV 64	VV 64.1	Type expansion	Weight gramm	Type	Price EURO
1							960	VV 61	
2							980	VV 61.1	
3							980	VV 62	
4							1010	VV 64	
5							960	VV 64.1	
7.1	Multi-axis controller left		(dir. 1-2, 3-4)					L	
7.2	Multi-axis controller right		(dir. 5-6, 7-8)					R	
10	Gate cross-shaped		(prohibits diagonal shifting)				60	P	
11	Gate special-shaped		(e.g. H-gate)				60	PX	
20	Control-handle with knob solid								
21	Control-handle with latch for mechanical zero interlock								
21.1	by lifting						50	M	
21.2	by lifting, interlocking the gate or the joint bracket						60	MP	
21.3	by pushing down						50	MN	
21.4	Mechanical zero interlock with command devices see catalog 1/282								
22	Control-handle with dead man's button 1 NO						100	T	
23	Control-handle with signal button 1 NO						100	H	
24	Control-handle with push button 1 NO						110	D	
25	Control-handle with flat push button 1 NO						110	DV	
26	Control-handle with palm grip B 1						40	B 1	
27	Control-handle with palm grip B 1 with push button top 1 NO						60	B 1T	
28	Control-handle long or short								
28.1			-40 mm					S3	
28.2			-20 mm					S5	
28.3			+20 mm					S8	
29	More knobs, grips and T-grips with and without signal devices see catalog 1/280...								
30	Masterswitch (contact set) switching sequenc 4-0-4					No. of contacts 2	290	01	
31						4	350	02	
32	Direction 1-2 and 3-4 each 1 masterswitch					6	410	03	
33	Switching program according contact-arrangement MS... see catalog 5/001				A...	8	470	04	
34	or to your contact-arrangement					10	530	05	
35						12	590	06	
36	Switching sequence 5-0-5 or 6-0-6								
38	Spring return in 0-position		(for each direction)			2	110	Z	
39	Friction brake adjustable		(for each direction)				30	R	
40	Potentiometer e.t.c. each masterswitch with mounted Wire-wound potentiometer T 130, with centre tap, 1,5 Watt wiper current max. 10 mA resistance 2 x 0,5k \cong P021, 2 x 1k \cong P022, 2 x 2k \cong P023, 2 x 5k \cong P024, 2 x 10k \cong P025					...P02 \square	70	P	
41	Prepared for mounting potentiometer shaft 6 mm adjusting-angle 2 x 150°							(P)	
42	Prepared for mounting potentiometer e.t.c. adjusting-angle variable.							(P)	
43	more Potentiometer e.t.c. see catalog 1/240...					C..., P...			
50	Steel sheet housing B 200 masterswitch max. size 04						1300	B	
51	Steel sheet housing B 230 x 440 masterswitch max. size 06						1600	B	
52	More housing see catalog 1/350								
60	Indicating labels not engraved with 2 or 4 arrows								
61	Engraving, each 10 characters								
70	Command and indicating devices see catalog 1/360								



T = dead man's button
H = signal button
M = latch for mechanical zero interlock

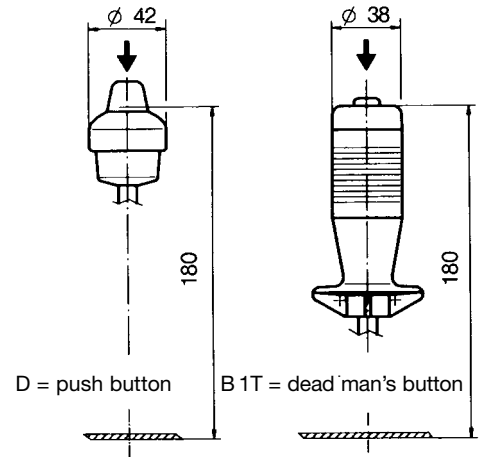
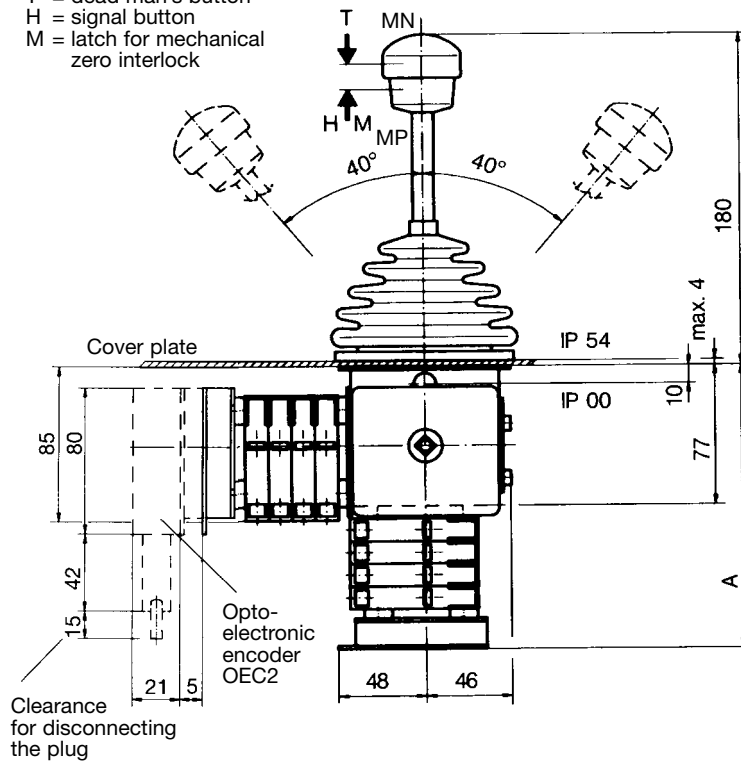

Type	No. of contacts	Dimension A	Dimension B
01	2	119	82
02	4	131	94
03	6	144	107
04	8	156	119
05	10	169	132
06	12	181	144

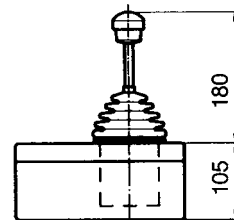
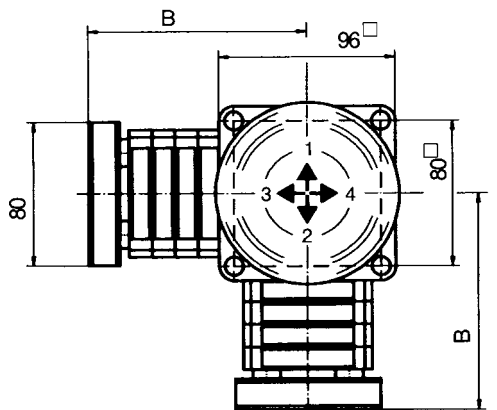

Steel sheet housing

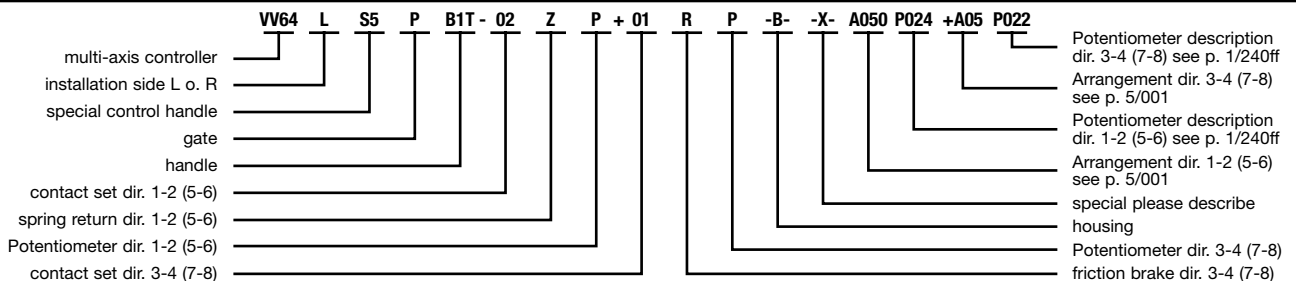
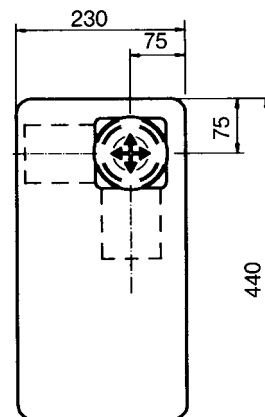
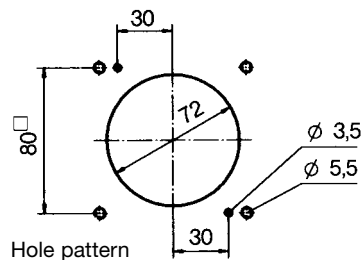



Type VA62L-01ZP+01Z-...

The multi-axis controller VA 6 is a rugged switching device according IEC 947-5-1 EN 60947 DIN VDE 0660-200 for hoisting applications. The modular design enables the switching device to be used universally. The VA 6 is resistant to oil, maritime climate, ozone and UV radiation.

Contact complement 2 A 250 V AC 15 res. 3 A 24 V DC 13

Mechanical life 10 million (operating cycles)
Operation -40° C to +60° C
Storage -50° C to +80° C

Climate resistance
Damp heat constant DIN IEC 68 part 2-3
Damp heat cyclic DIN IEC 68 part 2-30
Degree of protection front IP 54 IEC 529 DIN 40050
Technical data see catalog 5/100
Description data see catalog 5/002

Spindle block with schematic representation of the master controller installation and deflection directions.
Version shown for left-hand side installation (right-hand side installation is mirror image).

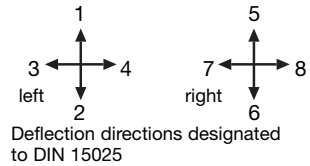

Pos.	VA 61	VA 61.1	VA 62	VV 64.1	Type expansion	Weight gramm	Type	Price EURO
1						960	VA 61	
2						980	VA 61.1	
3						980	VA 62	
4								
5								
7.1	Multi-axis controller left		(dir. 1-2, 3-4)				L	
7.2	Multi-axis controller right		(dir. 5-6, 7-8)				R	
10	Gate cross-shaped		(prohibits diagonal shifting)			60	P	
11	Gate special-shaped		(e.g. H-gate)			60	PX	
20	Control-handle with knob solid							
21	Control-handle with latch for mechanical zero interlock							
21.1	by lifting					50	M	
21.2	by lifting, interlocking the gate or the joint bracket					60	MP	
21.3	by pushing down					50	MN	
22	Control-handle with dead man's button 1 NO					100	T	
23	Control-handle with signal button 1 NO			Microchange over contact		100	H	
24	Control-handle with push button 1 NO			explosion protection		110	D	
25	Control-handle with flat push button 1 NO			EExdIICT 6		110	DV	
26	Control-handle with palm grip B 1			PTB No. Ex-91C 1083 X		40	B 1	
27	Control-handle with palm grip B 1 with push button top 1 NO			sealed cable		60	B 1T	
28	Control-handle long or short			3 metre long				
28.1			-40 mm				S3	
28.2			-20 mm				S5	
28.3			+20 mm				S8	
30	Masterswitch (contact) switching sequenc 4-0-4					No. of contacts 2	01	
31				Microchange over contact		4	02	
32	Direction 1-2 and 3-4 each 1 masterswitch			explosion protection		6	03	
33	Switching program according contact-arrangement MS see cat. 5/001			EExdIICT 6	A...	8	04	
34	or to your contact-arrangement			PTB No. Ex-91C 1083 X		10	05	
35				sealed cable		12	06	
36	Switching sequence 5-0-5 or 6-0-6			3 metre long				
38	Spring return in 0-position		(for each direction)			110	Z	
39	Friction brake adjustable		(for each direction)			30	R	
40	Potentiometer e.t.c. each masterswitch with mounted Wire-wound potentiometer T 238, with centre tap linear Life 5 x 10 ⁶ switching cycles resistance 2 x 5 kOhm, 1 Watt wiper current max. 10 mA in housing explosion protection EExdIICT 6 PTB-No. Ex-85/1131 sealed cable 3 metre long				...P084	70	P	
41	Prepared for mounting potentiometer shaft 6 mm adjusting-angle 2 x 150°						(P)	
42	Prepared for mounting potentiometer e.t.c. adjusting-angle variable.						(P)	
52	Housing see catalog 1/350							
60	Indicating labels not engraved with 2 or 4 arrows							
61	Engraving, each 10 characters							
70	Command and indicating devices on enquiry							



T = dead man's button
H = signal button
M = latch for mechanical zero interlock

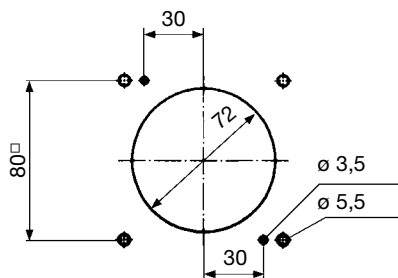
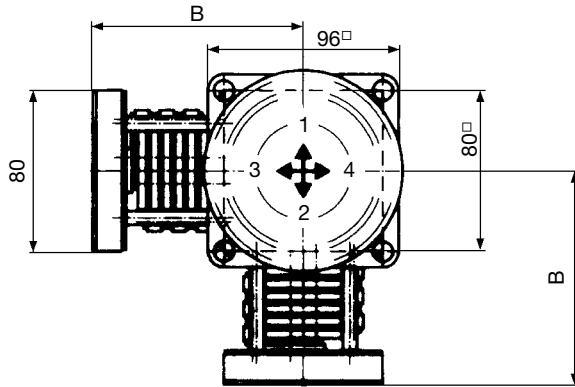
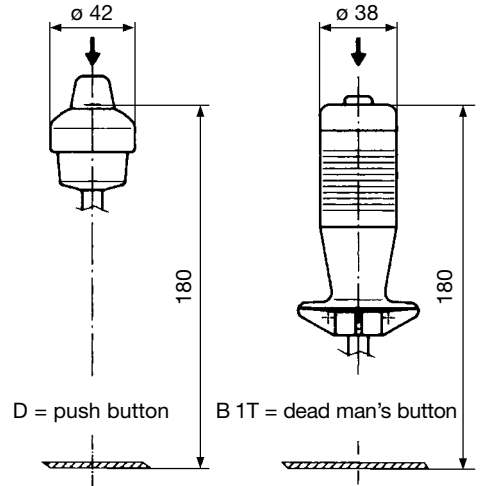
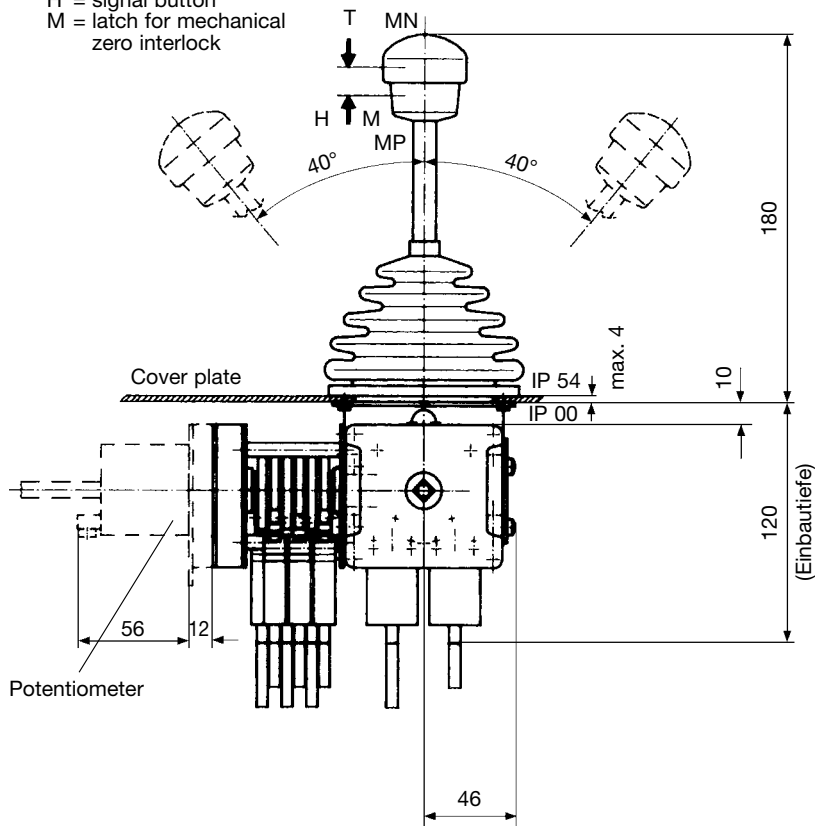

Hole pattern

Type	No. of contacts	Dimension B
01	2	82
02	4	94
03	6	107
04	8	119
05	10	132
06	12	144

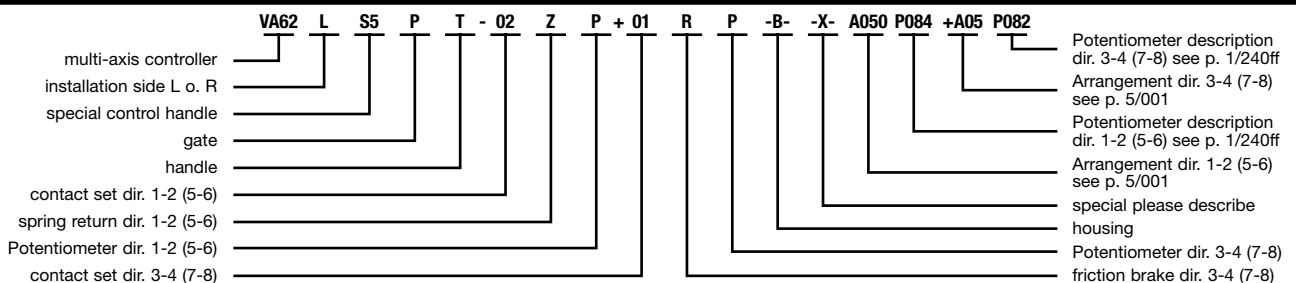



Type VVB64LD-06Z+06Z-...

The multi-axis controller VVB 6 is a rugged switching device according IEC 947-5-1 EN 60947 DIN VDE 0660-200 for hoisting applications. The modular design enables the switching device to be used universally. The VVB 6 is resistant to oil, maritime climate, ozone and UV radiation.

Contact complement 0,5 A 250 V DC 13

Mechanical life 20 million (operating cycles)
Permissible ambient temperature Operation -40° C to +60° C
Storage -50° C to +80° C

Climate resistance
Damp heat constant DIN IEC 68 part 2-3
Damp heat cyclic DIN IEC 68 part 2-30
Degree of protection front IP 54 IEC 529 DIN 40050
Technical data see catalog 5/100
Description data see catalog 5/002

Spindle block with schematic representation of the master controller installation and deflection directions.
Version shown for left-hand side installation (right-hand side installation is mirror image).

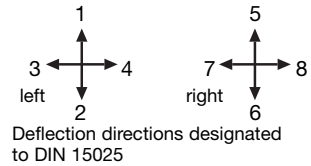

Pos.	VVB 61	VVB 61.1	VVB 62	VVB 64	VVB 64.1	Type expansion	Weight gramm	Type	Price EURO	
1							960	WB 61		
2							980	WB 61.1		
3							980	WB 62		
4							1010	WB 64		
5							960	WB 64.1		
7.1	Multi-axis controller left		(dir. 1-2, 3-4)				60	L		
7.2	Multi-axis controller right		(dir. 5-6, 7-8)				60	R		
10	Gate cross-shaped		(prohibits diagonal shifting)				110	P		
11	Gate special-shaped		(e.g. H-gate)				30	PX		
20	Control-handle with knob solid					Pos. 22-25, 27 not possible for VVB 64...				
21	Control-handle with latch for mechanical zero interlock									
21.1	by lifting						50	M		
21.2	by lifting, interlocking the gate or the joint bracket						60	MP		
21.3	by pushing down						50	MN		
21.4	Mechanical zero interlock with command devices see catalog 1/282									
22	Control-handle with dead man's button 1 NO						150	T		
23	Control-handle with signal button 1 NO						150	H		
24	Control-handle with push button 1 NO						160	D		
25	Control-handle with flat push button 1 NO						160	DV		
26	Control-handle with palm grip B 1					40	B 1			
27	Control-handle with palm grip B 1 with push button top 1 NO					110	B 1T			
28	Control-handle long or short									
28.1			-40 mm					S3		
28.2			-20 mm					S5		
28.3			+20 mm					S8		
29	More knobs, grips and T-grips with and without signal devices see catalog 1/280...									
30	Masterswitch (contact) switching sequenc 4-0-4					A...	No. of contacts 2	390	01	
31							4	550	02	
32	Direction 1-2 and 3-4 each 1 masterswitch						6	710	03	
33	Switching program according contact-arrangement MS... see catalog 5/001						8	970	04	
34	or to your contact-arrangement						10	1130	05	
35							12	1390	06	
36	Switching sequence 5-0-5 or 6-0-6									
38	Spring return in 0-position (for each direction)								Z	
39	Friction brake adjustable (for each direction)								R	
40	Potentiometer e.t.c. each masterswitch with mounted Wire-wound potentiometer T 130, with centre tap, 1,5 Watt wiper current max. 10 mA resistance 2 x 0,5k ≙ P021, 2 x 1k ≙ P022, 2 x 2k ≙ P023, 2 x 5k ≙ P024, 2 x 10k ≙ P025					...P02 □	70	P		
41	Prepared for mounting potentiometer shaft 6 mm adjusting-angle 2 x 150°								(P)	
42	Prepared for mounting potentiometer e.t.c. adjusting-angle variable.								(P)	
43	more Potentiometer e.t.c. see catalog 1/240...									
50										
60	Indicating labels not engraved with 2 or 4 arrows									
61	Engraving, each 10 characters									



T = dead man's button
H = signal button
M = latch for mechanical zero interlock

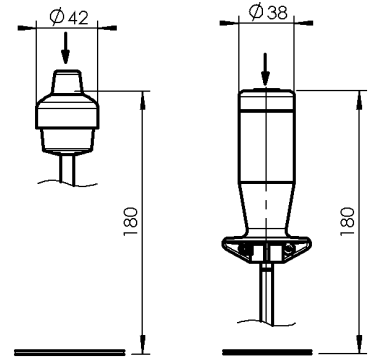
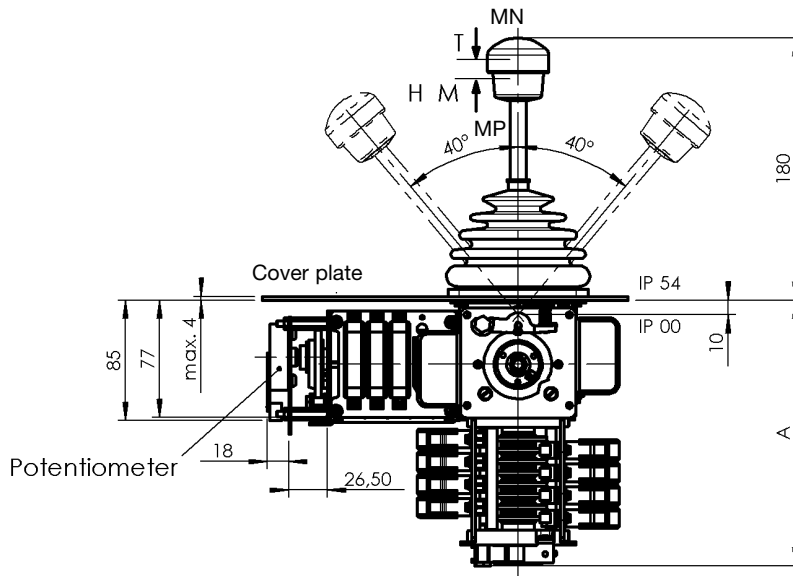

D = push button B 1T = dead man's button

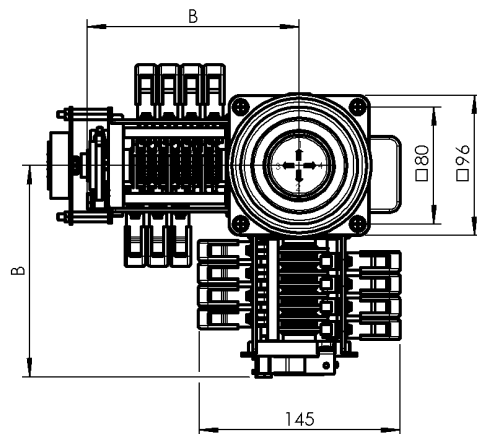

Hole pattern

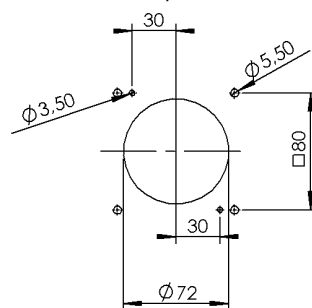

Type	No. of contacts	Dimension A	Dimension B
01	2	136	99
02	4	152	115
03	6	167	130
04	8	183	146
05	10	198	161
06	12	214	177

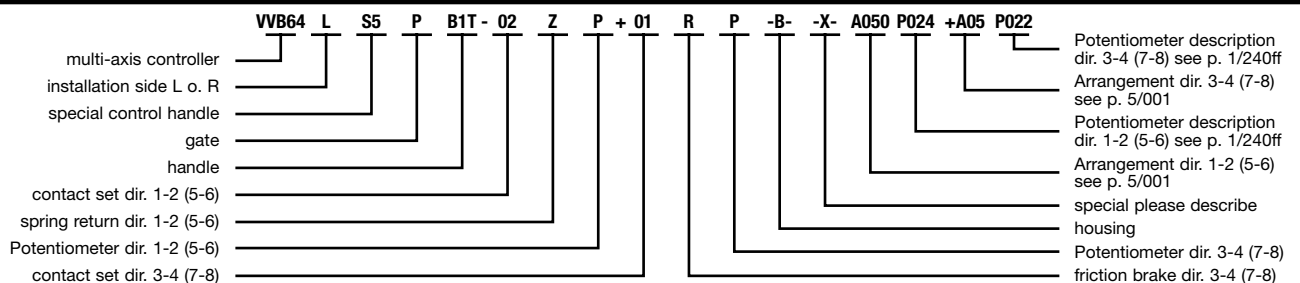



Type VVC64L-8Z+8Z...

The multi-axis controller VVC 6 is a rugged switching device according IEC 947-5-1 EN 60947 DIN VDE 0660-200 for hoisting applications. The modular design enables the switching device to be used universally. The VVC 6 is resistant to oil, maritime climate, ozone and UV radiation.

Contact complement 8 A 24 V DC 13

Mechanical life 20 million (operating cycles)
Permissible ambient temperature Operation -40° C to +60° C
Storage -50° C to +80° C

Climate resistance
Damp heat constant DIN IEC 68 part 2-3
Damp heat cyclic DIN IEC 68 part 2-30
Degree of protection front IP 54 IEC 529 DIN 40050
Technical data see catalog 5/100
Description data see catalog 5/002

Spindle block with schematic representation of the master controller installation and deflection directions.
Version shown for left-hand side installation (right-hand side installation is mirror image).

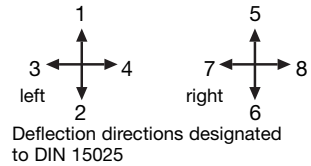

Pos.	VVC 61	VVC 61.1	VVC 62	VVC 64	VVC 64.1	Type expansion		Weight gramm	Type	Price EURO	
1								960	VVC 61		
2								980	VVC 61.1		
3								980	VVC 62		
4								1010	VVC 64		
5								960	VVC 64.1		
7.1	Multi-axis controller left		(dir. 1-2, 3-4)					60	L		
7.2	Multi-axis controller right		(dir. 5-6, 7-8)					60	R		
10	Gate cross-shaped		(prohibits diagonal shifting)					110	P		
11	Gate special-shaped		(e.g. H-gate)					30	PX		
20	Control-handle with knob solid										
21	Control-handle with latch for mechanical zero interlock										
21.1	by lifting							50	M		
21.2	by lifting, interlocking the gate or the joint bracket							60	MP		
21.3	by pushing/down							50	MN		
21.4	Mechanical zero interlock with command devices see catalog 1/282										
22	Control-handle with dead man's button 1 NO						Pos. 22-25, 27 not possible for VVC 64...	200	T		
23	Control-handle with signal button 1 NO							200	H		
24	Control-handle with push button 1 NO							210	D		
25	Control-handle with flat push button 1 NO							210	DV		
26	Control-handle with palm grip B 1							40	B 1		
27	Control-handle with palm grip B 1 with push button top 1 NO							160	B 1T		
28	Control-handle long or short										
28.1										S3	
28.2									S5		
28.3									S8		
29	More knobs, grips and T-grips with and without signal devices see catalog 1/280...										
30	Masterswitch (contact) switching sequenc 4-0-4						No. of contacts 2	490	2		
31							4	750	4		
32	Direction 1-2 and 3-4 each 1 masterswitch					A...	6	1010	6		
33	Switching program according contact-arrangement MS... see catalog 5/001						8	1370	8		
34	or to your contact-arrangement						10	1630	10		
35							12	1990	12		
36	Switching sequence 5-0-5 or 6-0-6										
38	Spring return in 0-position		(for each direction)						Z		
39	Friction brake adjustable		(for each direction)						R		
40											
50											
60	Indicating labels not engraved with 2 or 4 arrows										
61	Engraving, each 10 characters										



T = dead man's button
H = signal button
M = latch for mechanical zero interlock

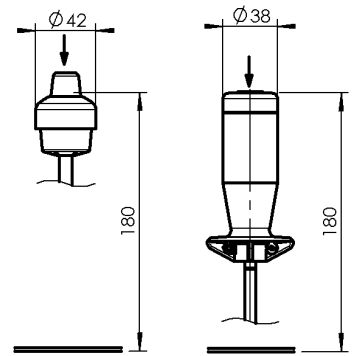
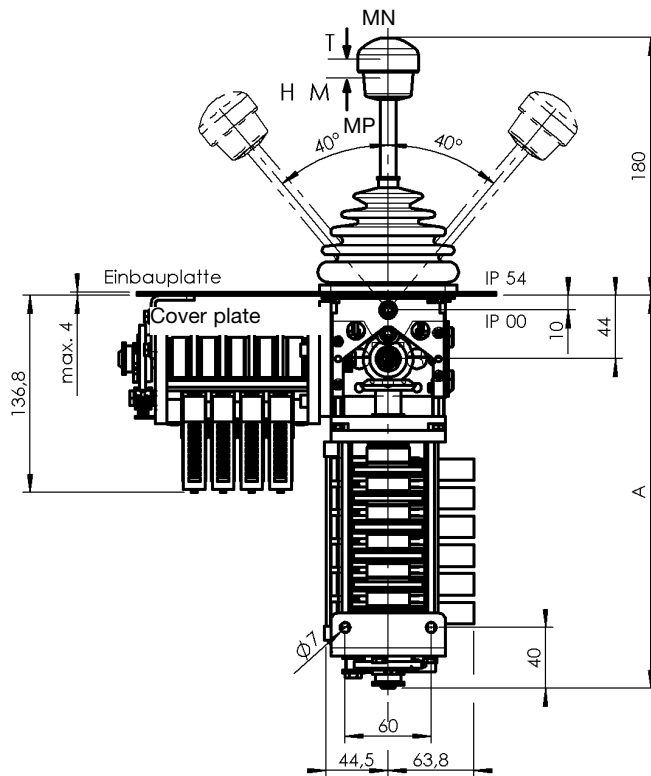

D = push button B 1T = dead man's button

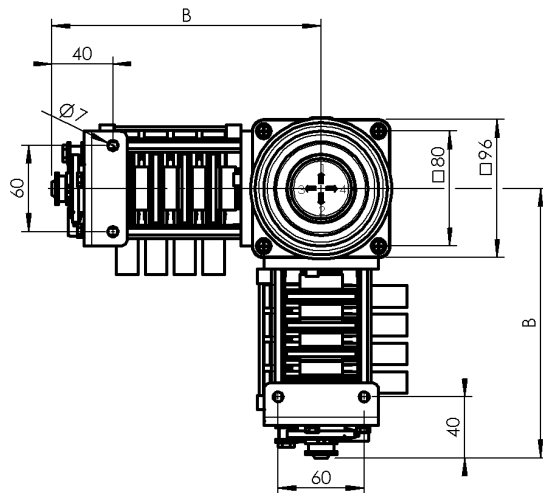

Type	No. of contacts	Dimension A	Dimension B
1	1	169	125
2	2	189	145
3	3	209	165
4	4	229	185
5	5	249	205
6	6	269	225
7	7	289	245
8	8	309	265
9	9	329	285
10	10	349	305
11	11	369	325
12	12	389	345

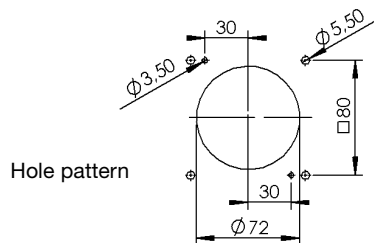

Hole pattern

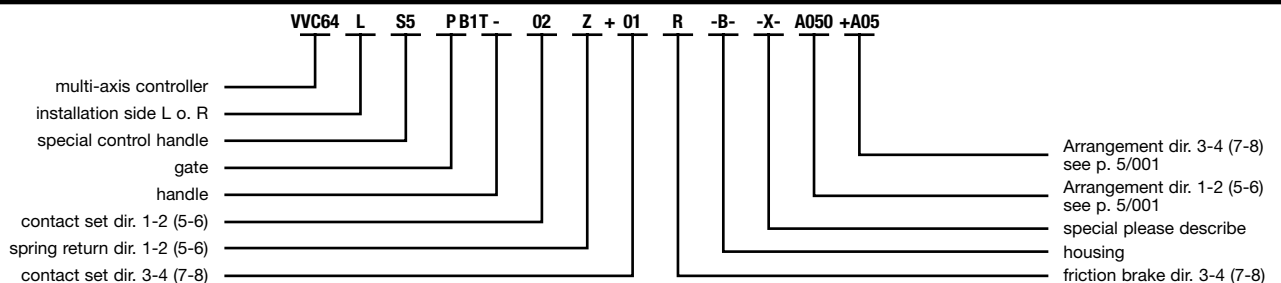



Type V11LT-02Z+02Z-...

The multi-axis controller V 11 is a rugged switching device according IEC 947-5-1 EN 60947 DIN VDE 0660-200 for hoisting applications. The modular design enables the switching device to be used universally. The V 11 is resistant to oil, maritime climate, ozone and UV radiation.

**Contact complement 2 A 250 V AC 15 res. 1 A 24 V DC 13 (standard)
or 4 A 250 V AC 15 (special)**

Mechanical life 10 million (operating cycles)
Permissible ambient temperature Operation -40° C to +60° C
Storage -50° C to +80° C

Climate resistance
Damp heat constant DIN IEC 68 part 2-3
Damp heat cyclic DIN IEC 68 part 2-30
Degree of protection front IP 54 IEC 529 DIN 40050
Technical data see catalog 5/100
Description data see catalog 5/002

Spindle block with schematic representation of the master controller installation and deflection directions.
Version shown for left-hand side installation left
(right-hand side installation is mirror image).

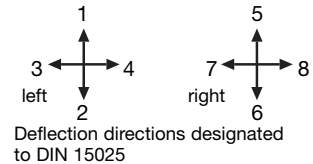

Pos.	V 11.1	V 11	Type expansion	Weight gramm	Type	Price EURO
1				400	V 11.1	
2						
3				500	V 11	
4						
5						
7.1	Multi-axis controller left	(dir. 1-2, 3-4)			L	
7.2	Multi-axis controller right	(dir. 5-6, 7-8)			R	
10	Gate cross-shaped	(prohibits diagonal shifting)		60	P	
11	Gate special-shaped	(e.g. H-gate)		60	PX	
20	Control-handle with knob solid					
21	Control-handle with latch for mechanical zero interlock					
21.1	by lifting			50	M	
21.2	by lifting, interlocking the gate or the joint bracket			60	MP	
21.3	by pushing down			50	MN	
21.4	Mechanical zero interlock with command devices see catalog 1/282					
22	Control-handle with dead man's button 1 NO			100	T	
23	Control-handle with signal button 1 NO			100	H	
24	Control-handle with push button 1 NO			110	D	
25	Control-handle with flat push button 1 NO			110	DV	
26	Control-handle with palm grip B 1			40	B 1	
27	Control-handle with palm grip B 1 with push button top 1 NO			60	B 1T	
28	Control-handle long or short					
28.1		-20 mm			S5	
28.2		+20 mm			S8	
29	More knobs, grips and T-grips with and without signal devices see catalog 1/280...					
30	Masterswitch (contact set) switching sequenc 4-0-4			No. of contacts 2	70	01
31				4	130	02
32	Direction 1-2 and 3-4 each 1 masterswitch			6	190	03
33	Switching program according contact-arrangement MS... see catalog 5/001		A...			
34	or to your contact-arrangement					
38	Spring return in 0-position	(for each direction)		25	Z	
39	Friction brake adjustable	(for each direction)		20	R	
40	Potentiometer e.t.c. each masterswitch with mounted Conductive-plastic potentiometer T 365, with centre tap linear Life 10 ⁷ switching cycles resistance 2 x 5 kOhm, 0,5 Watt wiper current max. 1 mA		...P324	70	P	
41	Prepared for mounting potentiometer shaft 6 mm adjusting-angle 2 x 150°				(P)	
42	Prepared for mounting potentiometer e.t.c. adjusting-angle variable.				(P)	
43	more Potentiometer e.t.c. see catalog 1/240...		C..., P...			
50	Plastic housing I 160 x 240, masterswitch max. size 03			800	I	
52	More housing see catalog 1/350					
60	Indicating labels not engraved with 2 or 4 arrows					
61	Engraving, each 10 characters					
70	Command and indicating devices see catalog 1/360					



T = dead man's button
H = signal button
M = latch for mechanical zero interlock

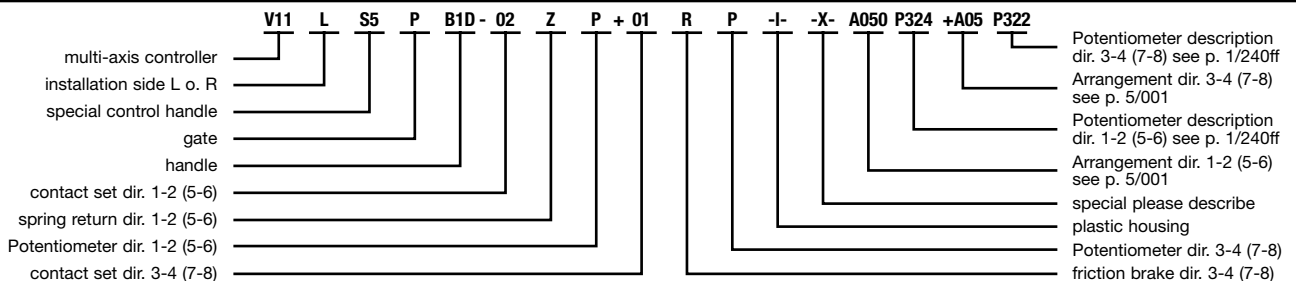
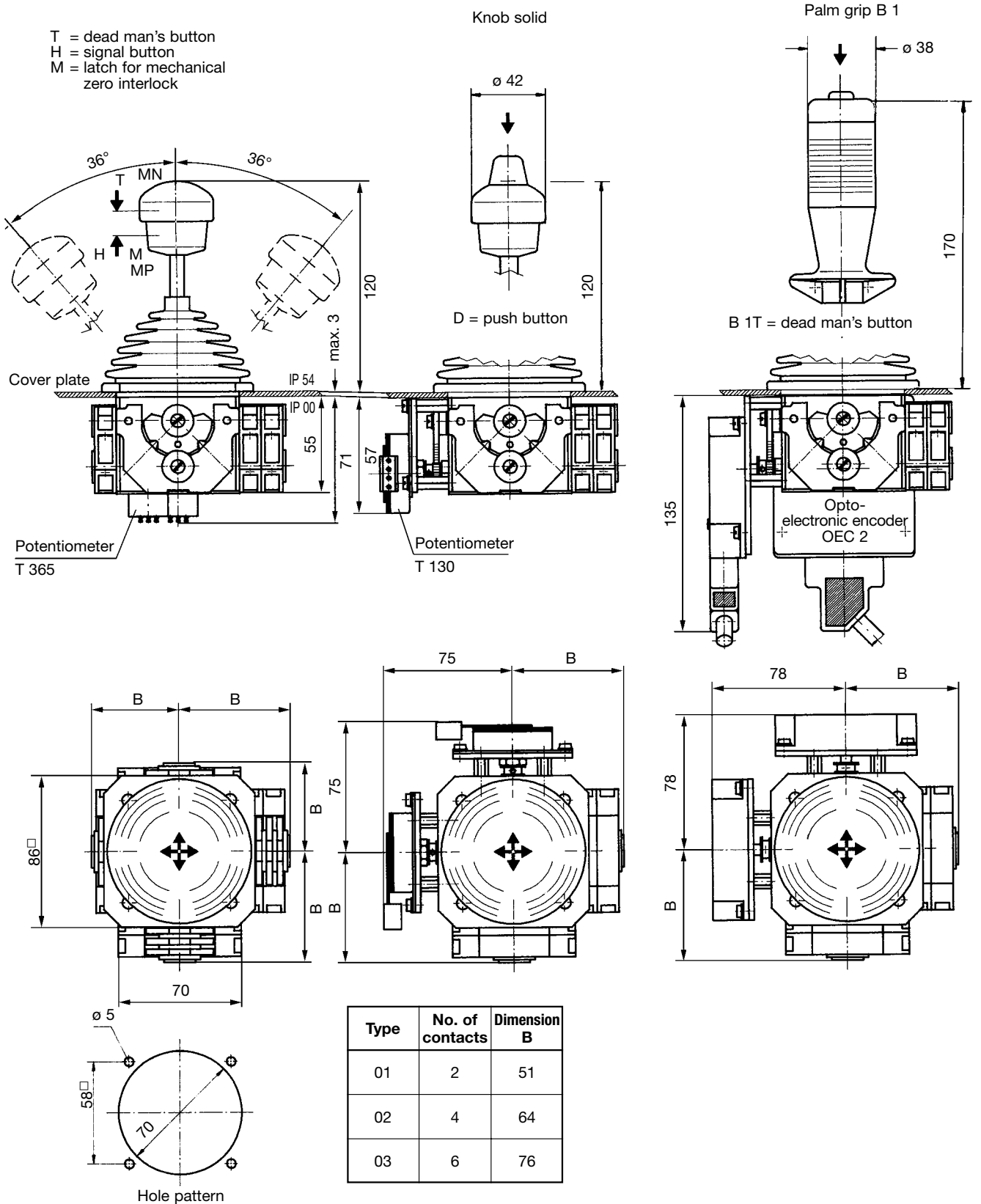

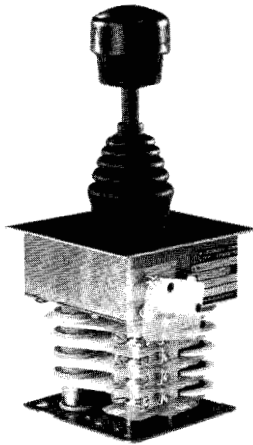

Type V5LT-4Z+4Z-...

The multi-axis controller V 5 is a rugged switching device according IEC 947-5-1 EN 60947 DIN VDE 0660-200 for hoisting applications. The modular design enables the switching device to be used universally. The V 5 is resistant to oil, maritime climate, ozone and UV radiation.

Contact complement 2 A 250 V AC 15 res. 3 A 24 V DC 13

Mechanical life 6 million (operating cycles)
Permissible ambient temperature Operation -40° C to +60° C
Storage -50° C to +80° C

Climate resistance
Damp heat constant DIN IEC 68 part 2-3
Damp heat cyclic DIN IEC 68 part 2-30
Degree of protection front IP 54 IEC 529 DIN 40050
Technical data see catalog 5/100
Description data see catalog 5/002

Spindle block with schematic representation of the master controller installation and deflection directions.
Version shown for left-hand side installation (right-hand side installation is mirror image).

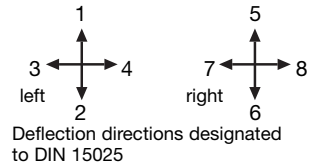

Pos.	V 51	V 5	Type expansion	Weight gramm	Type	Price EURO	
1				400	V 51		
2							
3					500	V 5	
4							
5							
7.1	Multi-axis controller left	(dir. 1-2, 3-4)			L		
7.2	Multi-axis controller right	(dir. 5-6, 7-8)			R		
10	Gate cross-shaped	(prohibits diagonal shifting)		50	P		
11	Gate special-shaped	(e.g. H-gate)		50	PX		
20	Control-handle with knob solid						
21	Control-handle with latch for mechanical zero interlock						
21.1	by lifting			50	M		
21.2	by lifting, interlocking the gate			60	MP		
21.3	by pushing down			50	MN		
21.4	Mechanical zero interlock with command devices see catalog 1/282						
22	Control-handle with dead man's button 1 NO			50	T		
23	Control-handle with signal button 1 NO			50	H		
24	Control-handle with push button 1 NO			60	D		
25	Control-handle with flat push button 1 NO			60	DV		
26	Control-handle with palm grip B 5			40	B 5		
27	Control-handle with palm grip B 5 with push button top 1 NO			60	B 5T		
28	Control-handle long or short						
28.1		-20 mm			S5		
28.2		+20 mm			S8		
29	More knobs, grips and T-grips with and without signal devices see catalog 1/280...						
30	Masterswitch (contact) switching sequenc 3-0-3		No. of contacts	1	1		
31				2	2		
32	Direction 1-2 and 3-4 each 1 masterswitch			3	3		
33	Switching program according contact-arrangement MS... see catalog 5/001 or to your contact-arrangement		A...	4	4		
34				5	5		
35				6	6		
36	Switching sequence 4-0-4						
37	Micro changeover contact (MZT 1) positive opening (additional price)			1			
38	Spring return in 0-position (for each direction)				25	Z	
39	Friction brake adjustable (for each direction)				30	R	
40	Potentiometer e.t.c. each masterswitch with mounted Wire-wound potentiometer T 130, with centre tap, 1,5 Watt wiper current max. 10 mA resistance 2 x 0,5k \cong P021, 2 x 1k \cong P022, 2 x 2k \cong P023, 2 x 5k \cong P024, 2 x 10k \cong P025		...P02 k		70	P	
41	Prepared for mounting potentiometer shaft 6 mm adjusting-angle 2 x 150°					(P)	
42	Prepared for mounting potentiometer e.t.c. adjusting-angle variable.					(P)	
43	more Potentiometer e.t.c. see catalog 1/240...		P...				
50	Plastic housing I 120 x 160, masterswitch max. size 6				600	I	
52	More housing see catalog 1/350						
60	Indicating labels not engraved with 2 or 4 arrows						
61	Engraving, each 10 characters						
70	Command and indicating devices see catalog 1/360						



T = dead man's button
H = signal button
M = latch for mechanical zero interlock

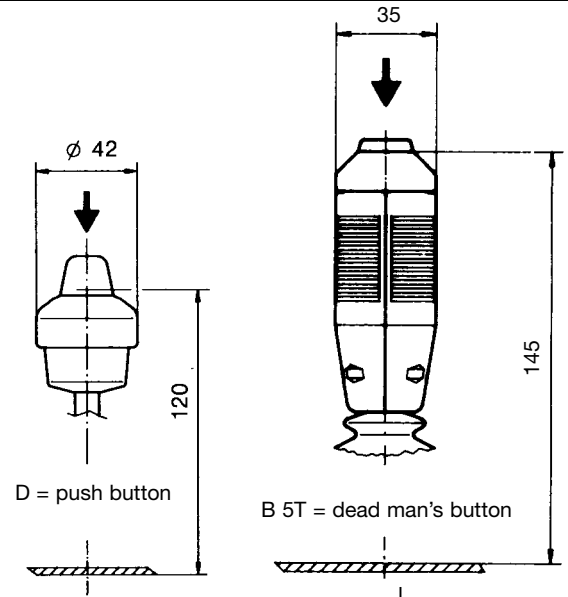
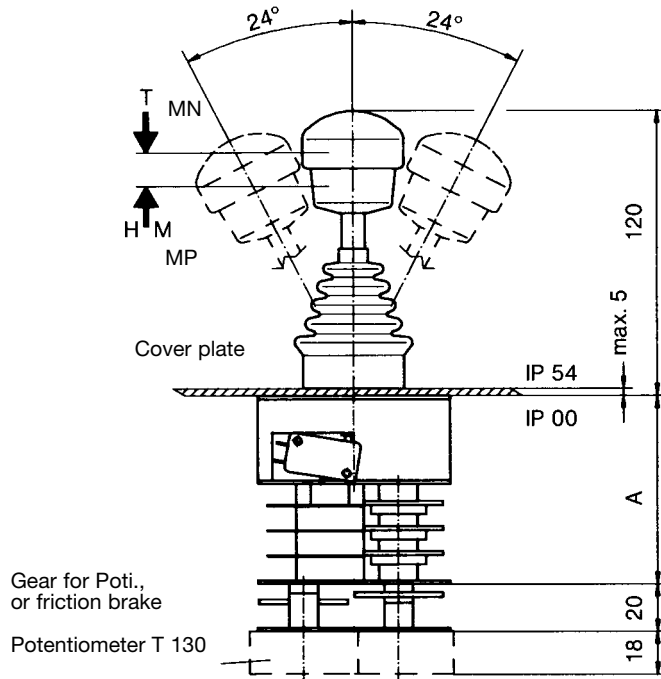

Type	No. of contacts	Dimension A
1	1	58
2	2	69
3	3	79
4	4	90
5	5	100
6	6	111

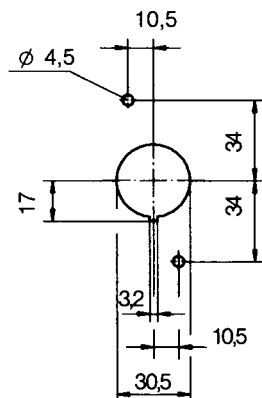
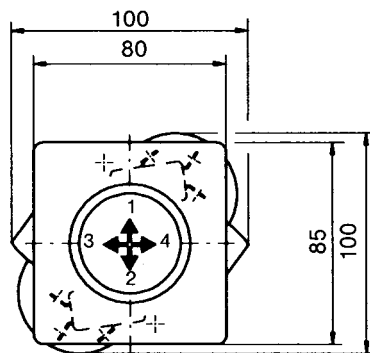

Hole pattern

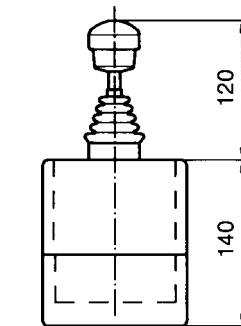

Plastic housing

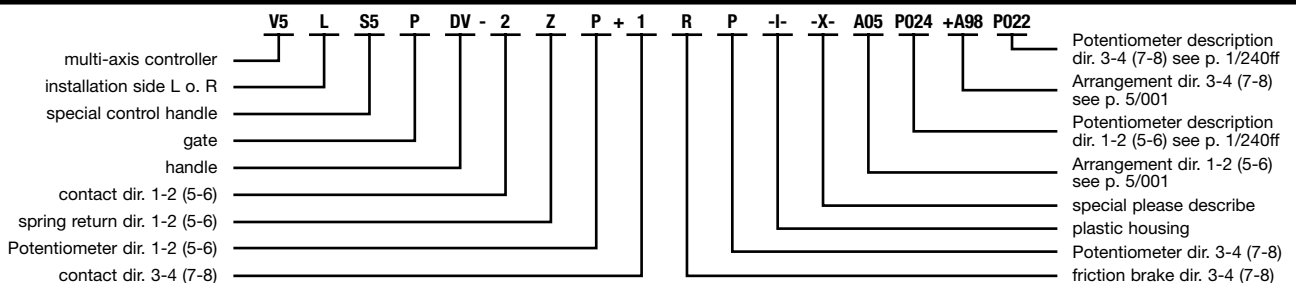
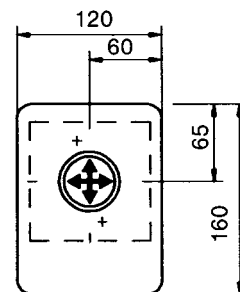

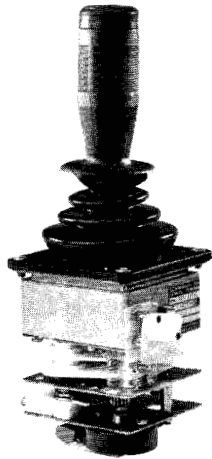

Type VV51LB1T-2RP-...

The multi-axis controller VV 5 is a rugged switching device according IEC 947-5-1 EN 60947 DIN VDE 0660-200 for electro-hydraulic applications. The modular design enables the switching device to be used universally. The VV 5 is resistant to oil, maritime climate, ozone and UV radiation.

Contact complement 2 A 250 V AC 15 res. 3 A 24 V DC 13

Mechanical life 10 million (operating cycles)
Permissible ambient temperature Operation -40° C to +60° C
Storage -50° C to +80° C

Climate resistance
Damp heat constant DIN IEC 68 part 2-3
Damp heat cyclic DIN IEC 68 part 2-30
Degree of protection front IP 54 IEC 529 DIN 40050
Technical data see catalog 5/100
Description data see catalog 5/002

Spindle block with schematic representation of the master controller installation and deflection directions.
Version shown for left-hand side installation (right-hand side installation is mirror image).

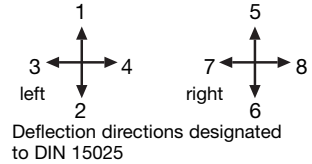

Deflection directions designated to DIN 15025

Pos.	VV 51	VV 5	Type expansion		Weight gramm	Type	Price EURO	
1					500	VV 51		
2								
3						600	VV 5	
4								
5								
7.1	Multi-axis controller left	(dir. 1-2, 3-4)				L		
7.2	Multi-axis controller right	(dir. 5-6, 7-8)				R		
10	Gate cross-shaped	(prohibits diagonal shifting)			60	P		
11	Gate special-shaped	(e.g. H-gate)			60	PX		
20	Control-handle with knob solid							
21	Control-handle with latch for mechanical zero interlock							
21.1	by lifting				50	M		
21.2	by lifting, interlocking the gate or the joint bracket				60	MP		
21.3	by pushing down				50	MN		
21.4	Mechanical zero interlock with command devices see catalog 1/282							
22	Control-handle with dead man's button	1 NO			100	T		
23	Control-handle with signal button	1 NO			100	H		
24	Control-handle with push button	1 NO			110	D		
25	Control-handle with flat push button	1 NO			110	DV		
26	Control-handle with palm grip B	1			40	B 1		
27	Control-handle with palm grip B 1 with push button top	1 NO			60	B 1T		
28	Control-handle long or short							
28.1		-20 mm				S5		
28.2		+20 mm				S8		
29	More knobs, grips and T-grips with and without signal devices see catalog 1/280...							
30	Masterswitch (contact) switching sequenc 3-0-3			No. of contacts	1	1		
31					2	2		
32	Direction 1-2 and 3-4 each 1 masterswitch				3	3		
33	Switching program according contact-arrangement MS... see catalog 5/001		A...		4	4		
34	or to your contact-arrangement				5	5		
35					6	6		
36	Switching sequence 4-0-4				200	6		
38	Spring return in 0-position	(for each direction)			25	Z		
39	Friction brake adjustable	(for each direction)			30	R		
40	Potentiometer e.t.c. each masterswitch with mounted Wire-wound potentiometer T 130, with centre tap, 1,5 Watt wiper current max. 10 mA resistance 2 x 0,5k \pm P021, 2 x 1k \pm P022, 2 x 2k \pm P023, 2 x 5k \pm P024, 2 x 10k \pm P025		...P02 <input type="checkbox"/>		70	P		
41	Prepared for mounting potentiometer shaft 6 mm adjusting-angle 2 x 150°					(P)		
42	Prepared for mounting potentiometer e.t.c. adjusting-angle variable.					(P)		
43	more Potentiometer e.t.c. see catalog 1/240...		P...					
50	Plastic housing I 120 x 160, masterswitch max. size 4				600	I		
52	More housing see catalog 1/350							
60	Indicating labels not engraved with 2 or 4 arrows							
61	Engraving, each 10 characters							
70	Command and indicating devices see catalog 1/360							



T = dead man's button
H = signal button
M = latch for mechanical zero interlock

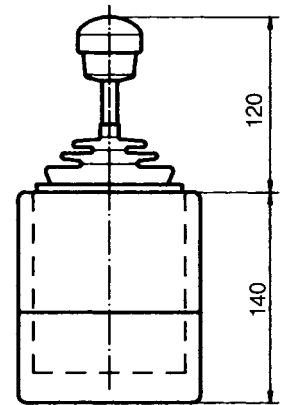
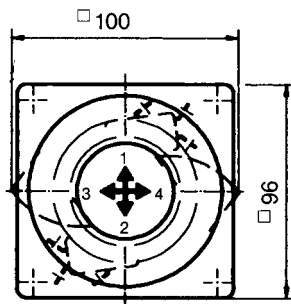
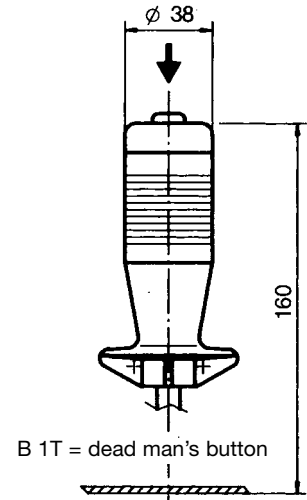
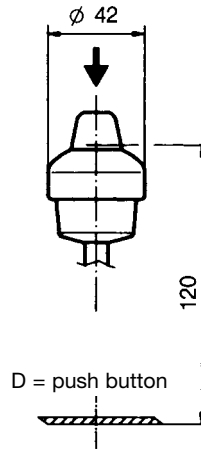
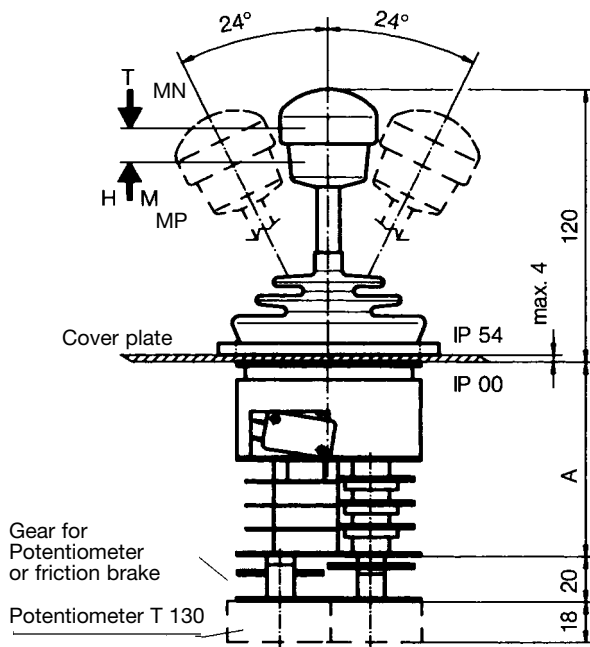

Plastic housing

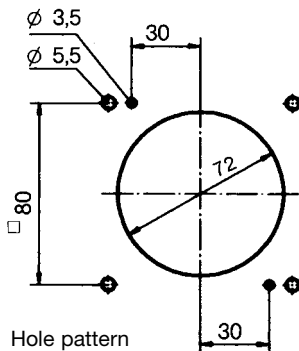

Type	No. of contacts	Dimension A
1	1	66
2	2	77
3	3	87
4	4	98
5	5	108
6	6	119

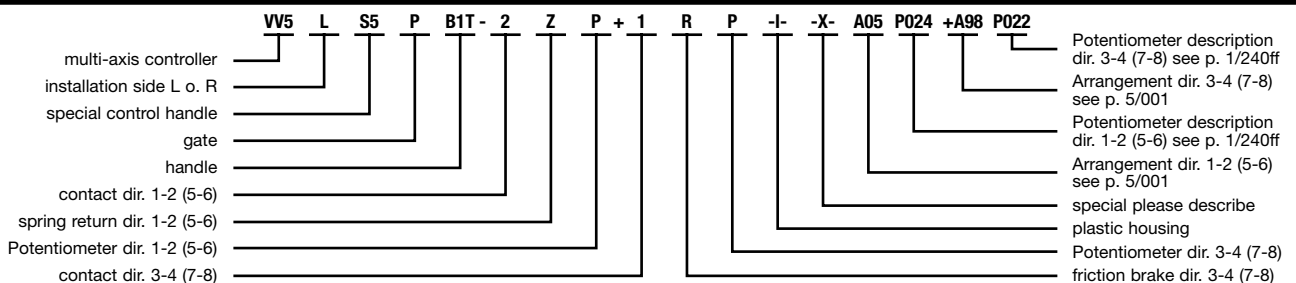
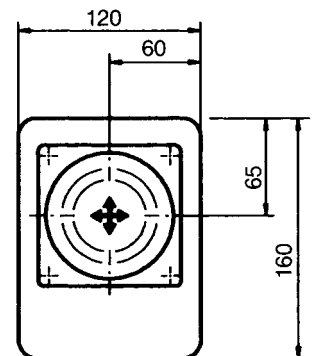



Type V8LB3DSRPA12-2ZP+2ZP-...

The multi-axis controller V 8 is a rugged switching device according IEC 947-5-1 EN 60947 DIN VDE 0660-200 for electro-hydraulic applications. The modular design enables the switching device to be used universally. The V 8 is resistant to oil, maritime climate, ozone and UV radiation.

Contact complement 0,5 A 110 V AC 15 res. 1,5 A 24 V DC 13
I min > 0,2 mA 2 V DC 12 Gold plated for max. load of 0,12 Watt (standard)

Mechanical life V 8	10 million (operating cycles)
Mechanical life VV 8	20 million (operating cycles)
Permissible ambient temperature	Operation -40° C to +60° C
	Storage -50° C to +80° C
Climate resistance	
Damp heat constant	DIN IEC 68 part 2-3
Damp heat cyclic	DIN IEC 68 part 2-30
Degree of protection front	IP 54 IEC 529 DIN 40050
Technical data see catalog 5/100	
Description data see catalog 5/002	

Spindle block with schematic representation of the master controller installation and deflection directions.
Version shown for left-hand side installation (right-hand side installation is mirror image).

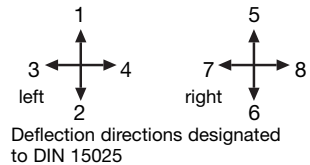

Pos.	V 81	V 8	Type expansion	Weight gramm	Type	Price EURO
1	1	1		800	V 81	
2	↑	↑		800	VV 81	
3	○	3 ← ○ → 4		900	V 8	
4	↓	↓		900	VV 8	
5	2	2				
7.1	Multi-axis controller left	(dir. 1-2, 3-4)			L	
7.2	Multi-axis controller right	(dir. 5-6, 7-8)			R	
10	Gate cross-shaped	(prohibits diagonal shifting)		60	P	
11	Gate special-shaped	(e.g. H-gate)		60	PX	
20	Control-handle with knob solid					
21	Control-handle with latch for mechanical zero interlock					
21.1	by lifting			50	M	
21.2	by lifting, interlocking the gate or the joint bracket			60	MP	
21.3	by pushing down			50	MN	
21.4	Mechanical zero interlock with command devices see catalog 1/282					
22	Control-handle with dead man's button 1 NO			100	T	
23	Control-handle with signal button 1 NO			100	H	
24	Control-handle with push button 1 NO			110	D	
25	Control-handle with flat push button 1 NO			110	DV	
26	Control-handle with palm grip B 1			40	B 1	
27	Control-handle with palm grip B 1 with push button top 1 NO			60	B 1T	
28	Control-handle long or short					
28.1		-20 mm			S5	
28.2		+20 mm			S8	
29	More knobs, grips and T-grips with and without signal devices see catalog 1/280...					
30	Masterswitch (contact) switching sequenc -0-		No. of contacts	1	20	1
31				2	40	2
32	Direction 1-2 and 3-4 each 1 masterswitch			3	60	3
33	Switching program according contact-arrangement MS... see catalog 5/001		A...			
34	or to your contact-arrangement					
36	Switching sequence 3-0-3					
38	Spring return in 0-position	(for each direction)			30	Z
39	Friction brake adjustable	(for each direction)			30	R
40	Potentiometer e.t.c. each masterswitch with mounted		...P18 □		70	P
41	Conductive-plastic potentiometer T 301, with centre tap linear					
42	0,5 Watt wiper current max. 1 mA					
43	resistance 2 x 1k ≙ P182, 2 x 2k ≙ P183, 2 x 5k ≙ P184, 2 x 10k ≙ P185					
41	Prepared for mounting potentiometer shaft 6 mm adjusting-angle 2 x 120°					(P)
42	Prepared for mounting potentiometer e.t.c. adjusting-angle variable.					(P)
43	more Potentiometer e.t.c. see catalog 1/240...		P...			
45	Electronic (Amplifier, Profi-Bus, CAN-Bus) see catalog 3/510/...		E...			
50	Cover housing				300	B
51	Filter plug M 20 for air-condition				20	
52	Cable entry M 20 with anti-kink protection and strain relief				30	
53	Plug in socket	14-pole female insert CPC 17 wired			150	
54	Connector	14-pole male insert CPC 17 unwired			150	
55	Wiring plug in socket or connector each wired-connection					
60	Indicating labels not engraved with 2 or 4 arrows					
61	Engraving, each 10 characters					



T = dead man's button
H = signal button
M = latch for mechanical zero interlock

Knob solid
D = -push button

Palm grip B 1
B 1T = dead man's button
see catalog 1/284

Palm grip B 2
for the 3. direction 9-10
see catalog 1/285

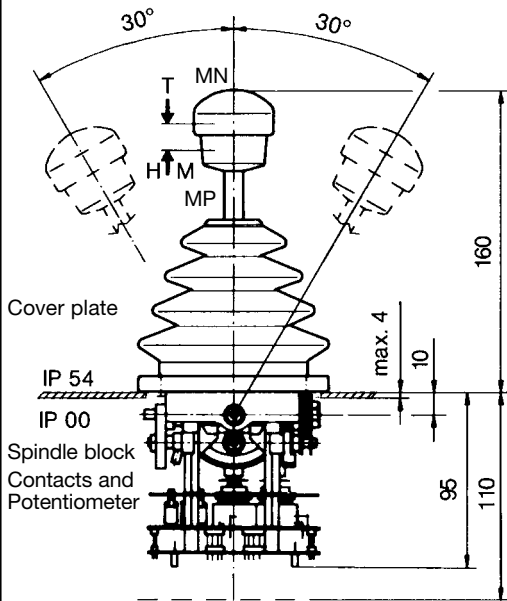

Expanse for impedance-converter and board with solder-, plug-, or screw terminal

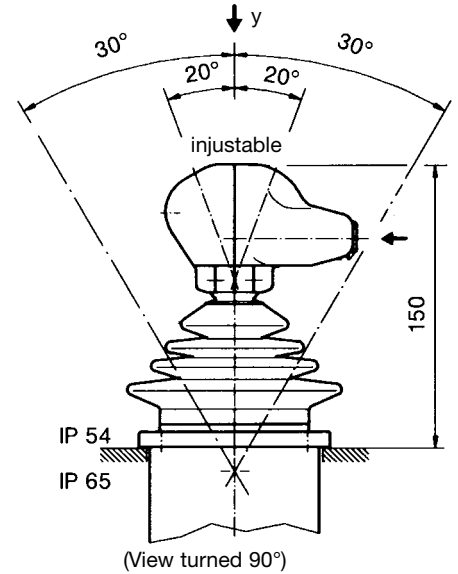
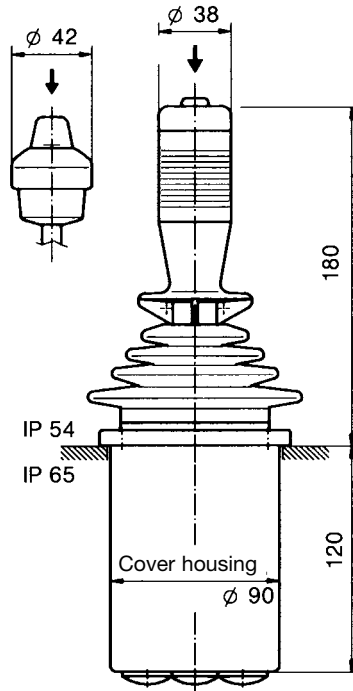

Palm grip B 3
see catalog 1/286
for the 3. direction 11-12
for the 4. direction 13-14

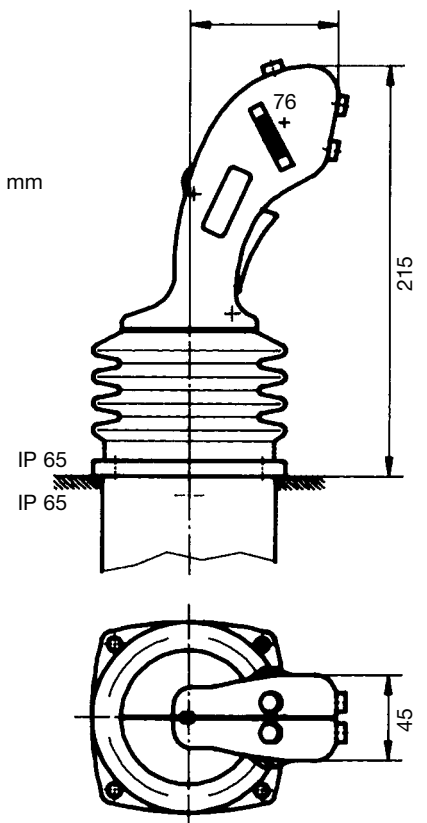
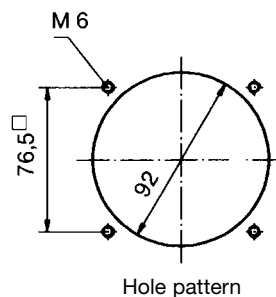
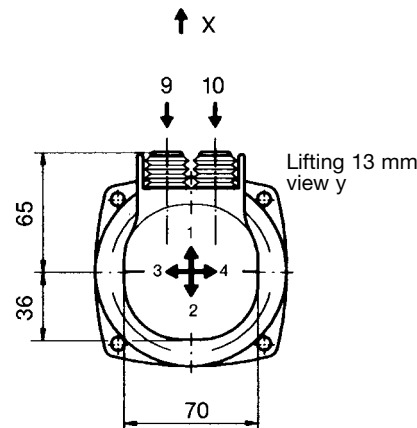
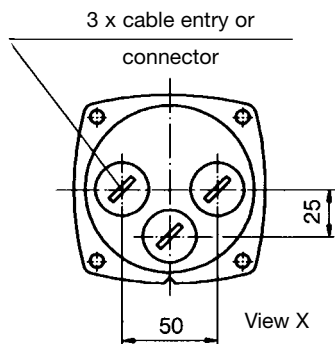
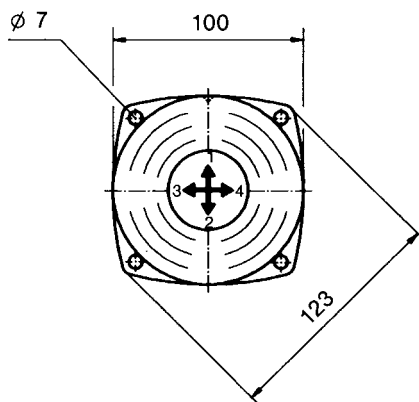

	V8	L	S5	P	B3K - 3	Z	P + 1	R	P	-B-	-X-	A050	P184	+A98	P182	
multi-axis controller																Potentiometer description dir. 3-4 (7-8) see p. 1/240ff
installation side L o. R																Arrangement dir. 3-4 (7-8) see p. 5/001
special control handle																Potentiometer description dir. 1-2 (5-6) see p. 1/240ff
gate																Arrangement dir. 1-2 (5-6) see p. 5/001
handle																special please describe housing
contact dir. 1-2 (5-6)																Potentiometer dir. 3-4 (7-8)
spring return dir. 1-2 (5-6)																friction brake dir. 3-4 (7-8)
Potentiometer dir. 1-2 (5-6)																
contact dir. 3-4 (7-8)																



Type V85L-2ZS+2ZS-B...

The multi-axis controller V 85 is a rugged switching device according IEC 947-5-1 EN 60947 DIN VDE 0660-200 for electro-hydraulic applications. The modular design enables the switching device to be used universally. The V 85 is resistant to oil, maritime climate, ozone and UV radiation.

Contact complement 0,5 A 110 V AC 15 res. 1,5 A 24 V DC 13
I min > 0,2 mA 2 V DC 12 Gold plated for max. load of 0,12 Watt (standard)

Mechanical life V 85	10 million (operating cycles)
Mechanical life VV 85	20 million (operating cycles)
Permissible ambient temperature	Operation -40° C to +60° C
	Storage -50° C to +80° C
Climate resistance	
Damp heat constant	DIN IEC 68 part 2-3
Damp heat cyclic	DIN IEC 68 part 2-30
Degree of protection front	IP 54 IEC 529 DIN 40050
Technical data see catalog 5/100	
Description data see catalog 5/002	

Spindle block with schematic representation of the master controller installation and deflection directions.

Version shown for left-hand side installation (right-hand side installation is mirror image).

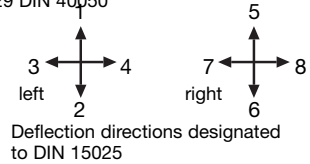

Pos.	V 85.1	V 85	Type expansion	Weight gramm	Type	Price EURO
1				800	V 85.1	
2				800	VV 85.1	
3				900	V 85	
4				900	VV 85	
5						
7.1	Multi-axis controller left	(dir. 1-2, 3-4)			L	
7.2	Multi-axis controller right	(dir. 5-6, 7-8)			R	
10	Gate cross-shaped	(prohibits diagonal shifting)		60	P	
11	Gate special-shaped	(e.g. H-gate)		60	PX	
20	Control-handle with knob solid					
21	Control-handle with latch for mechanical zero interlock by lifting			50	M	
22	Control-handle with dead man's button 1 NO			100	T	
23	Control-handle with signal button 1 NO			100	H	
24	Control-handle with push button 1 NO			110	D	
25	Control-handle with flat push button 1 NO			110	DV	
26	Control-handle with palm grip B 1			40	B 1	
27	Control-handle with palm grip B 1 with push button top 1 NO			60	B 1T	
28	Control-handle long or short					
28.1		-20 mm			S5	
28.2		+20 mm			S8	
29	More knobs, grips and T-grips with and without signal devices see catalog 1/280...					
30	Masterswitch (contact) switching sequenc -0-			No. of contacts 1	1	
31				2	2	
32	Direction 1-2 and 3-4 each 1 masterswitch					
33	Switching program according contact-arrangement MS... see catalog 5/001		A...			
34	or to your contact-arrangement					
38	Spring return in 0-position	(for each direction)		30	Z	
39	Friction brake adjustable	(for each direction)		30	R	
40	Potentiometer e.t.c. each masterswitch with mounted Magnet KEM for redundant Hallsensors			70	S	
42	Voltage output impressed 0,5-2,5-4,5 Volt electronic for 1 axis		EU 15			
43	electronic for 2 axis		EU 16			
	Technical data: Power supply 4,6-5,5 Volt output 0,5-2,5-4,5 Volt + 5 mA, output characteristic Linear					
45	more Electronic (Amplifier, Profi-Bus, CAN-Bus) see catalog 3/510/...		E...			
50	Cover housing			300	B	
51	Filter plug M 20 for air-condition			20		
52	Cable entry M 20 with anti-kink protection and strain relief			30		
53	Plug in socket 9-pole female insert D-SUB9 wired			150		
54	Connector 9-pole male insert D-SUB9 unwired			150		
55	Wiring plug in socket or connector each wired-connection					
60	Indicating labels not engraved with 2 or 4 arrows					
61	Engraving, each 10 characters					



T = dead man's button
H = signal button

Knob solid
D = -push button

Palm grip B 1
B 1T = dead man's button
see catalog 1/283

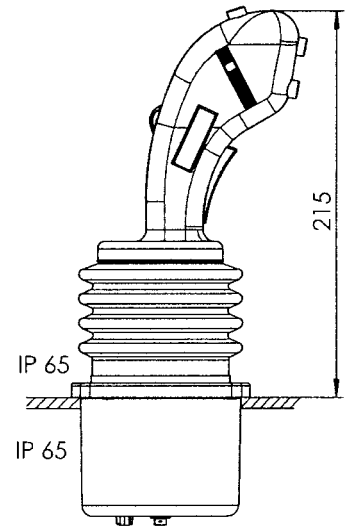
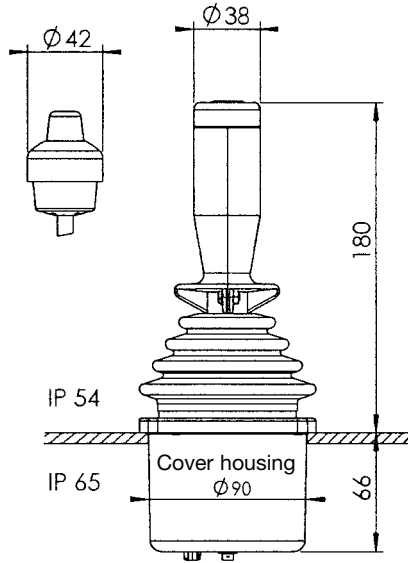
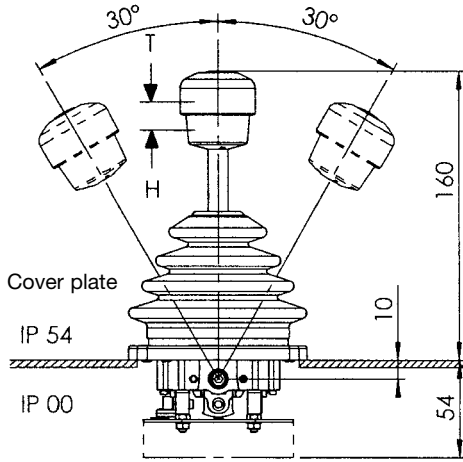

Palm grip B 3
see catalog 1/286
for the 3. direction 11-12
for the 4. direction 13-14

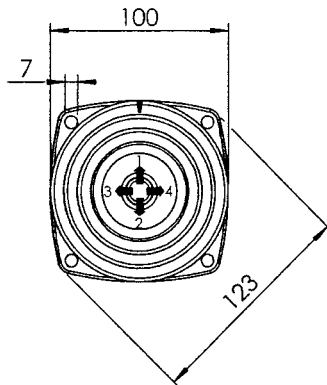

View A

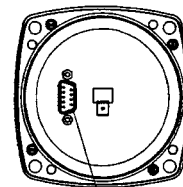

Plug in socket D-SUB9

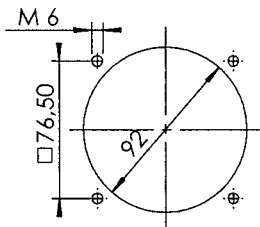
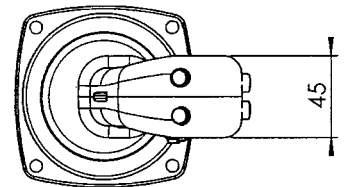

Hole pattern

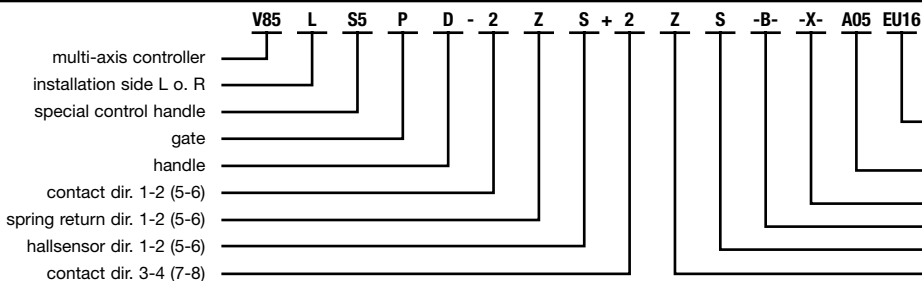

electronic description
dir. 1-2 (5-6) + dir. 3-4 (7-8)
see p. 1/240ff
Arrangement dir. 1-2 (5-6) +
dir. 3-4 (7-8) see p. 5/001
special please describe
housing
Hallsensor dir. 3-4 (7-8)
spring return dir. 3-4 (7-8)



Type V25LT-2ZS+2ZS-B...

The multi-axis controller V 25 is a rugged switching device according IEC 947-5-1 EN 60947 DIN VDE 0660-200 for electro-hydraulic applications. The modular design enables the switching device to be used universally. The V 25 is resistant to oil, maritime climate, ozone and UV radiation.

**Contact complement 0,5 A 110 V AC 15 res. 1,5 A 24 V DC 13
I min > 0,2 mA 2 V DC 12 Gold plated for max. load of 0,12 Watt (standard)**

Mechanical life V 25 8 million (operating cycles)
Permissible ambient temperature Operation -40° C to +60° C
Storage -50° C to +80° C
Climate resistance
Damp heat constant DIN IEC 68 part 2-3
Damp heat cyclic DIN IEC 68 part 2-30
Degree of protection front IP 54 IEC 529 DIN 40050
Technical data see catalog 5/100
Description data see catalog 5/002

Spindle block with schematic representation of the master controller installation and deflection directions.
Version shown for left-hand side installation (right-hand side installation is mirror image).

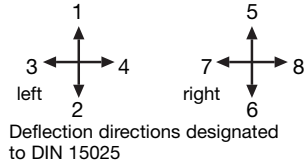

Pos.	V 25.1	V 25	Type expansion	Weight gramm	Type	Price EURO
1				500	V 25.1	
2						
3				500	V 25	
4						
5						
7.1	Multi-axis controller left	(dir. 1-2, 3-4)			L	
7.2	Multi-axis controller right	(dir. 5-6, 7-8)			R	
10	Gate cross-shaped	(prohibits diagonal shifting)		60	P	
11	Gate special-shaped	(e.g. H-gate)		60	PX	
20	Control-handle with knob solid					
21	Control-handle with latch for mechanical zero interlock by lifting			50	M	
22	Control-handle with dead man's button 1 NO			100	T	
23	Control-handle with signal button 1 NO			100	H	
24	Control-handle with push button 1 NO			110	D	
25	Control-handle with flat push button 1 NO			110	DV	
26	Control-handle with palm grip B 1			40	B 1	
27	Control-handle with palm grip B 1 with push button top 1 NO			60	B 1T	
28	Control-handle long or short					
28.1		+20 mm				
29	More knobs, grips and T-grips with and without signal devices see catalog 1/280...				S8	
30	Masterswitch (contact) switching sequenc -0-			No. of contacts 1	1	
31				2	2	
32	Direction 1-2 and 3-4 each 1 masterswitch					
33	Switching program according contact-arrangement MS... see catalog 5/001		A...			
34	or to your contact-arrangement					
38	Spring return in 0-position	(included in the spindle block)		30	Z	
40	Potentiometer e.t.c. each masterswitch with mounted Magnet KEM for redundant Hallsensors			70	S	
42	Voltage output impressed 0,5-2,5-4,5 Volt electronic for 1 axis		EU 15			
43	electronic for 2 axis		EU 16			
	Technical data: Power supply 4,6-5,5 Volt output 0,5-2,5-4,5 Volt + 5 mA, output characteristic Linear					
45	more Electronic (Amplifier, Profi-Bus, CAN-Bus) see catalog 3/510/...					
50	Cover housing		E...	300	B	
51	Filter plug M 20 for air-condition			20		
52	Cable entry M 20 with anti-kink protection and strain relief			30		
53	Plug in socket 9-pole female insert D-SUB9 wired			150		
54	Connector 9-pole male insert D-SUB9 unwired			150		
55	Wiring plug in socket or connector each wired-connection					
60	Indicating labels not engraved with 2 or 4 arrows					
61	Engraving, each 10 characters					



T = dead man's button
H = signal button
M = latch for mechanical zero interlock

Knob solid
D = -push button

Palm grip B 1
B 1T = dead man's button
see catalog 1/283

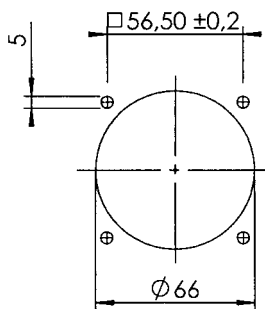
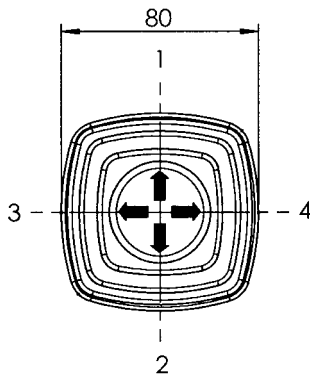
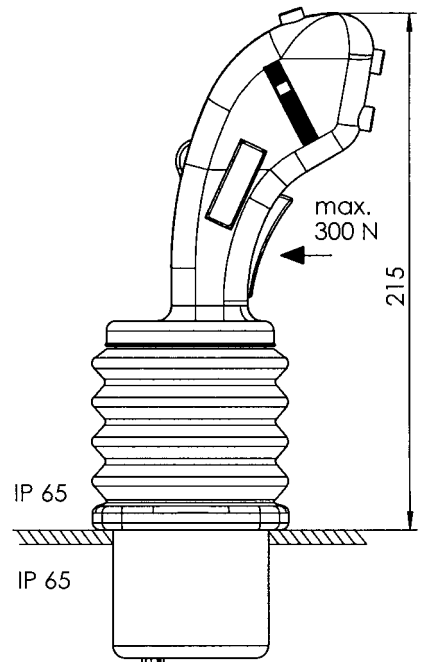
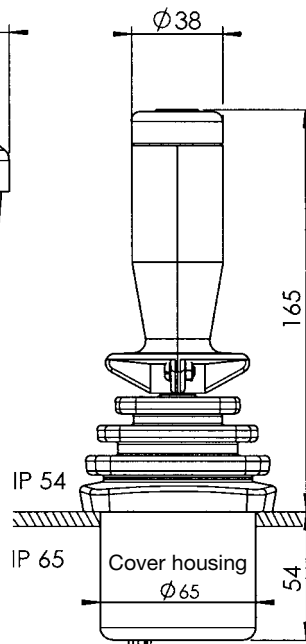
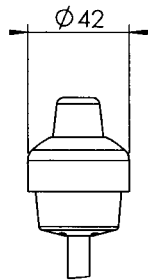
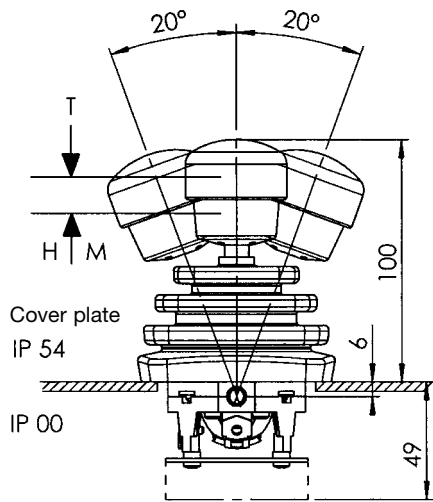

Hole pattern

↑
A

View A

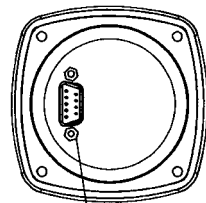

Plug in socket D-SUB9

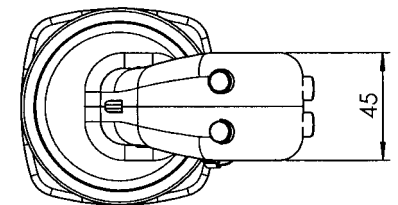

Palm grip B 3
see catalog 1/286
for the 3. direction 11-12
for the 4. direction 13-14

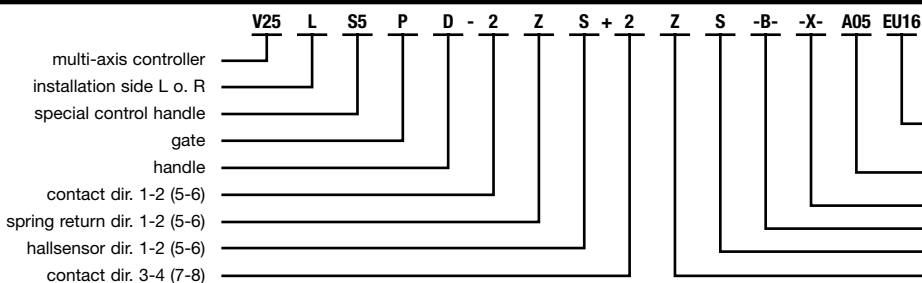

electronic description
dir. 1-2 (5-6) + dir. 3-4 (7-8)
see p. 1/240ff
Arrangement dir. 1-2 (5-6) +
dir. 3-4 (7-8) see p. 5/001
special please describe
housing
hallsensor dir. 3-4 (7-8)
spring return dir. 3-4 (7-8)



Type V10L-01ZP+01ZP-...

The multi-axis controller V 10 is a rugged switching device according IEC 947-5-1 EN 60947 DIN VDE 0660-200 for remote control and electro-hydraulic applications. The V 10 is resistant to oil, maritime climate, ozone and UV radiation.

Contact complement 0,5 A 110 V AC 15 res. 1,5 A 24 V DC 13
I min > 0,2 mA 2 V DC 12 Gold plated for max. load of 0,12 Watt (standard)

Mechanical life 8 million (operating cycles)
Permissible ambient temperature Operation -40° C to +60° C
Storage -50° C to +80° C

Climate resistance
Damp heat constant DIN IEC 68 part 2-3
Damp heat cyclic DIN IEC 68 part 2-30
Degree of protection front IP 54 IEC 529 DIN 40050
Technical data see catalog 5/100
Description data see catalog 5/002

Spindle block with schematic representation of the master controller installation and deflection directions. Version shown for left-hand side installation (right-hand side installation is mirror image).

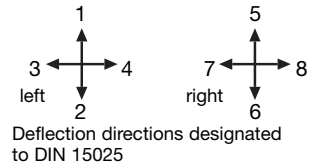

Pos.	V 10.1	V 10	Type expansion	Weight gramm	Type	Price EURO	
1				200	V 10.1		
2							
3					250	V 10	
4							
5							
7.1	Multi-axis controller left	(dir. 1-2, 3-4)			L		
7.2	Multi-axis controller right	(dir. 5-6, 7-8)			R		
10	Gate cross-shaped	(prohibits diagonal shifting)		20	P		
11	Gate special-shaped	(e.g. H-gate)		20	PX		
20	Control-handle with knob solid						
21	Control-handle with latch for mechanical zero interlock by lifting			50	M		
21.1				80	T		
22	Control-handle with dead man's button 1 NO						
23							
24							
25							
26	Control-handle with palm grip B 5			40	B 5		
27	Control-handle with palm grip B 5 with push button top 1 NO			60	B 5D		
28							
29	More knobs, grips and T-grips with and without signal devices see catalog 1/280...						
30	Masterswitch (contact) without switching sequence		No. of contacts	20	01		
31			4	40	02		
32	Direction 1-2 and 3-4 each 1 masterswitch		6	60	03		
33	Switching program according contact-arrangement MS... see catalog 5/001 or to your contact-arrangement		A...				
34							
35							
36	Switching sequence 4-0-4						
38	Spring return in 0-position	(included in the spindle block)			Z		
39	Friction brake adjustable	(for each direction)			R		
40	Potentiometer e.t.c. each masterswitch with mounted Conductive-plastic potentiometer T 320, with centre tap linear 0,5 Watt wiper current max. 1 mA resistance 2 x 1k \cong P252, 2 x 5k \cong P254		...P25 \square	20	P		
41							
42							
43	more Potentiometer e.t.c. see catalog 1/240...		P...				
45	Electronic (Amplifier, Profi-Bus, CAN-Bus) see catalog 3/510/...		E...				
50	Plastic housing I 122 x 120			350	I		
51							
52	More housing see catalog 1/350						
60	Indicating labels not engraved with 2 or 4 arrows						
61	Engraving, each 10 characters						
70	Command and indicating devices see catalog 1/360						



Knob solid

T = dead man's button

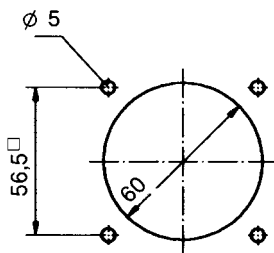
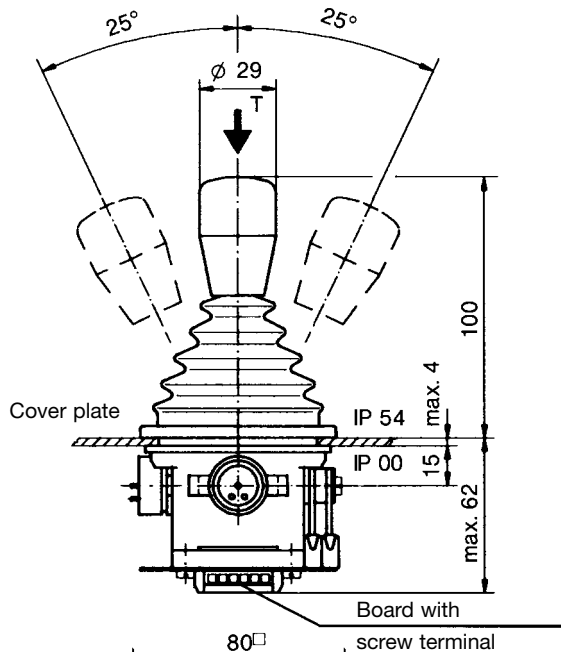

Hole pattern

Ball grip

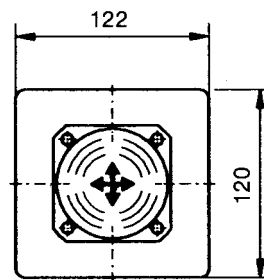
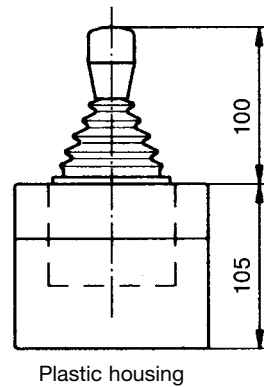
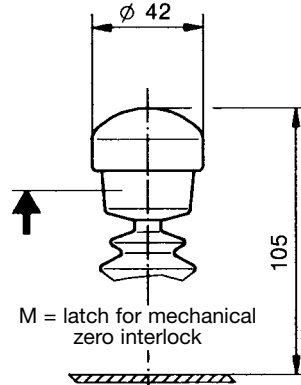

Palm grip B 5

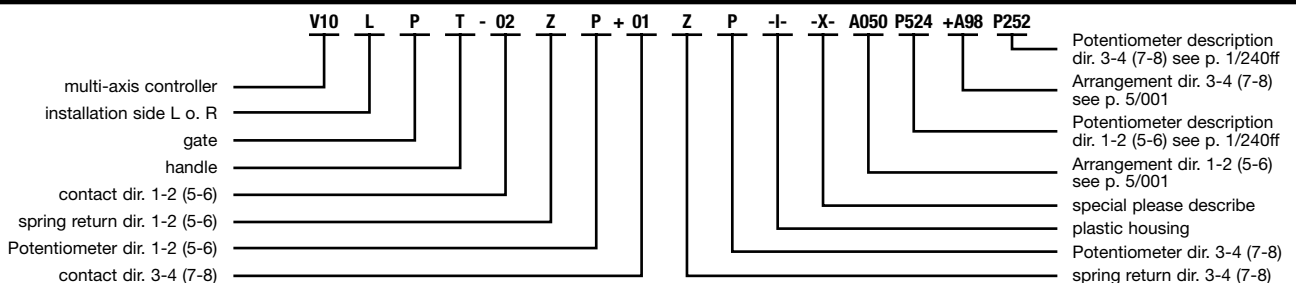
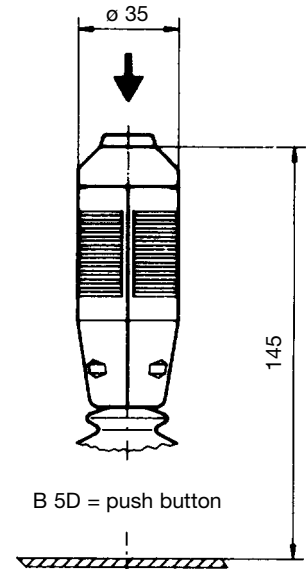



Type V14L-03Z+00CZ-...

The multi-axis controller V 14 is a rugged switching device according IEC 947-5-1 EN 60947 DIN VDE 0660-200 for remote control and hoisting applications.

The V 14 is resistant to oil, maritime climate, ozone and UV radiation.

Contact complement 2 A 250 V AC 15 res. 1 A 24 V DC 13

Mechanical life 6 million (operating cycles)
Permissible ambient temperature Operation -40° C to +60° C
Storage -50° C to +80° C

Climate resistance
Damp heat constant DIN IEC 68 part 2-3
Damp heat cyclic DIN IEC 68 part 2-30
Degree of protection front IP 65 IEC 529 DIN 40050
Description data see catalog 5/002

Spindle block with schematic representation of the master controller installation and deflection directions.
Version shown for left-hand side installation (right-hand side installation is mirror image).

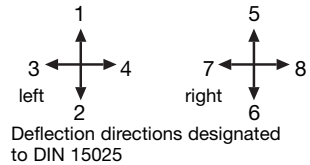

Pos.	V 14.1	V 14	Type expansion		Weight gramm	Type	Price EURO	
1					175	V 14.1		
2								
3						200	V 14	
4								
5								
7.1	Multi-axis controller left	(dir. 1-2, 3-4)				L		
7.2	Multi-axis controller right	(dir. 5-6, 7-8)				R		
10	Gate cross-shaped	(prohibits diagonal shifting)			20	P		
11	Gate special-shaped	(e.g. H-gate)			20	PX		
20	Control-handle with knob solid							
21	Control-handle with latch for mechanical zero interlock							
21.1	by lifting				50	M		
21.2	by lifting, interlocking the joint bracket				60	MP		
21.3	by pushing down				50	MN		
21.4	Mechanical zero interlock with command devices see catalog 1/282							
22	Control-handle with dead man's button 1 NO				80	T		
23	Control-handle with signal button 1 NO				80	H		
28	Control-handle long +20 mm					S8		
29	More knobs, grips and T-grips with and without signal devices see catalog 1/280...							
30	Masterswitch (contact set) switching sequenc 4-0-4 adjustable (with encoder 6-0-6)			No. of contacts	2	01		
31					4	02		
32	Direction 1-2 and 3-4 each 1 masterswitch				6	03		
33	Switching program according contact-arrangement MS... see catalog 5/001							
34	or to your contact-arrangement							
38	Spring return in 0-position	(included in the spindle block)	A...			Z		
39	Friction brake adjustable	(for each direction)				R		
44	Mechanical encoder with mounted direction 1-2 and 3-4 each 1 encoder life 5 x 106 switching cycles, 0,5 Watt wiper current max. 1 mA							
	Mechanical encoder MEC 1-2 male connector EA/02-10 contact-arrangement MS 26-0 see catalog 5/001				30	C		
	Conductive-plastic potentiometer with centre tap linear resistance 2 x 10 kOhm		C61					
45	Mechanical encoder MEC 1-7 male connector EA / 10-10 contact-arrangement MS 26-0-1 see catalog 5/001				20	C		
	Conductive-plastic potentiometer with centre tap linear resistance 2 x 5 kOhm		C62					
46	Mechanical encoder MEC 1-6 male connector EA / 09-10, 6 Bit Gray-Code				30	C		
47	Mechanical encoder MEC 1-6-5 male connector ER / 36-10 Power supply 24 V DC, output power impressed 4-20 mA				30	C		
			C63					
48	Mechanical encoder MEC 1-6-8 male connector ER / 36-12 Power supply 24 V DC, output power impressed 0-20 mA				30	C		
			C64					
49	Mechanical encoder MEC 1-10 male connector EA / 17-10 contact-arrangement MS21-0 + MS21 see catalog 5/001				30	C		
	Conductive-plastic potentiometer with centre tap Linear resistance 2 x 1,5 kOhm		C66					
52	Housing see catalog 1/350							
60	Indicating labels not engraved with 2 or 4 arrows							
61	Engraving, each 10 characters							
70	Command and indicating devices see catalog 1/360							



T = dead man's button
H = signal button
M = latch for mechanical zero interlock

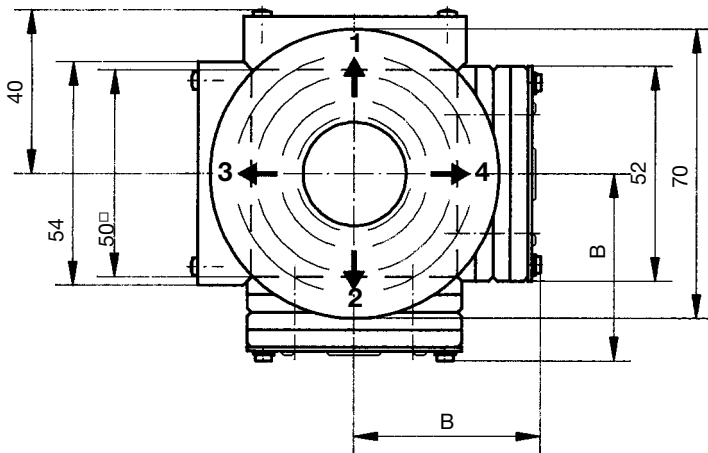
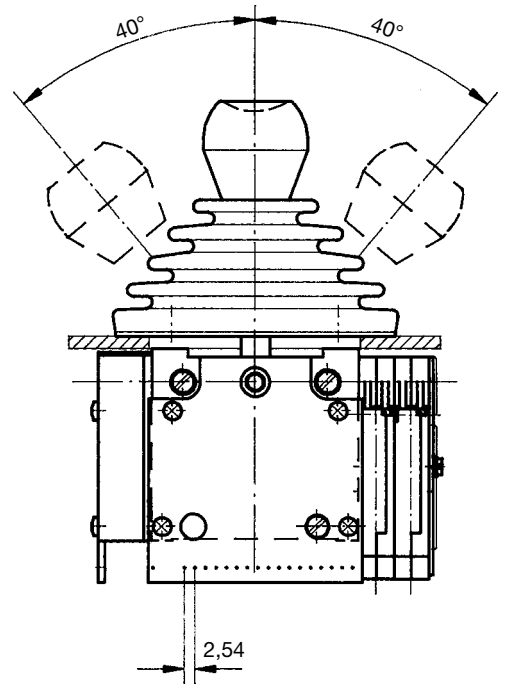
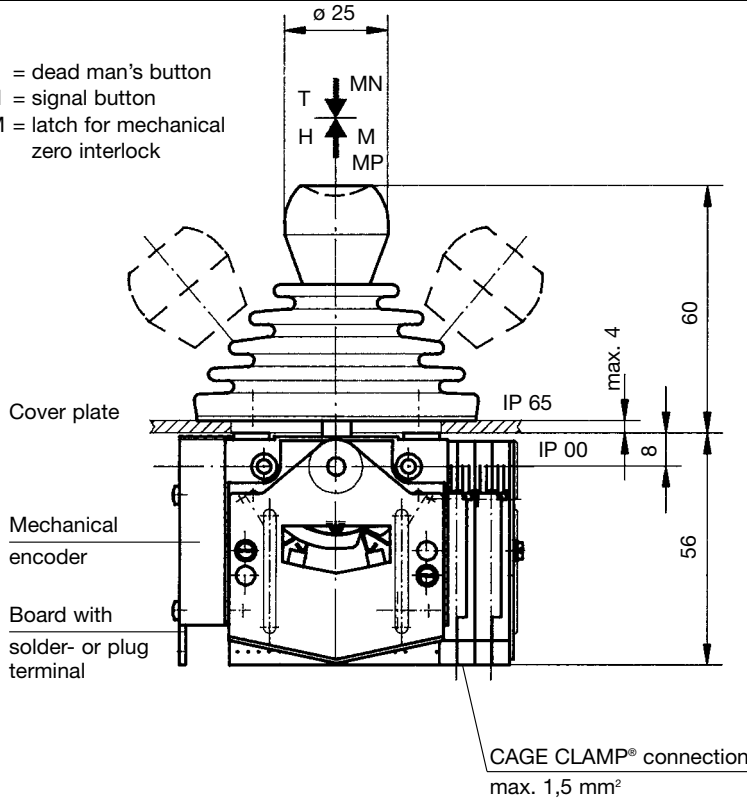

Type	No. of contacts	Dimen. B
01	2	36
02	4	45
03	6	54

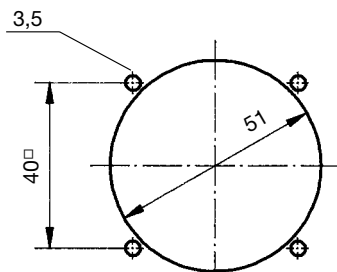

Hole pattern

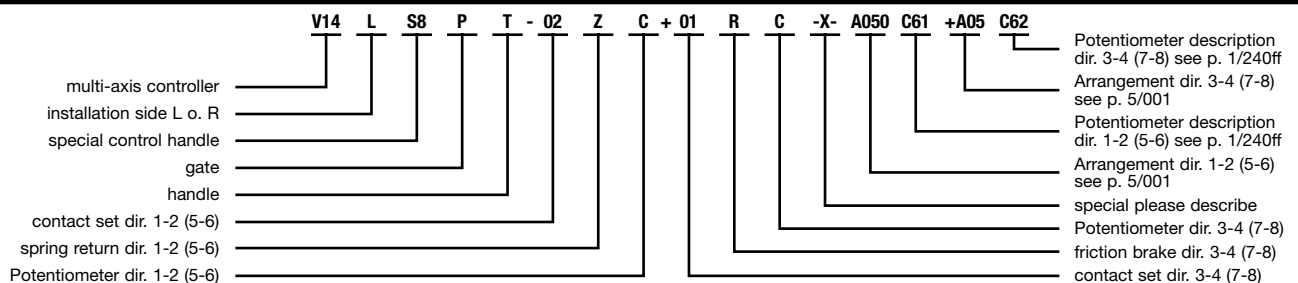

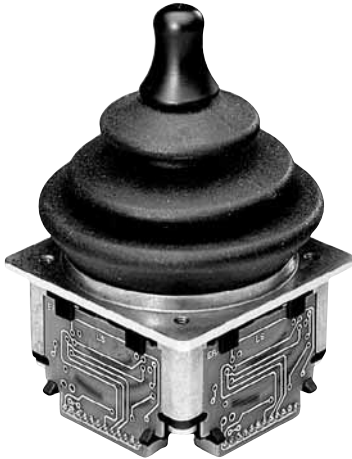

Type V20L-0ZC+0ZC-...

The multi-axis controller V 20 is a rugged switching device according IEC 947-5-1 EN 60947 DIN VDE 0660-200 for remote control and other applications.

The V 20 is resistant to oil, maritime climate, ozone and UV radiation.

Mechanical life 3 million (operating cycles)
Permissible ambient temperature Operation -30° C to +70° C
Storage -50° C to +80° C

Climate resistance
Damp heat constant DIN IEC 68 part 2-3
Damp heat cyclic DIN IEC 68 part 2-30
Degree of protection front IP 65 IEC 529 DIN 40050

Description data see catalog 5/002

Spindle block with schematic representation of the master controller installation and deflection directions.

Version shown for left-hand side installation (right-hand side installation is mirror image).

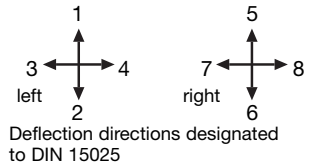

Pos.	V 20.1	V 20	Type expansion	Weight gramm	Type	Price EURO	
1				80	V 20.1		
2							
3					90	V 20	
4							
5							
6	Degree of Protection, front IP67 by bellow						
7.1	Multi-axis controller left	(dir. 1-2, 3-4)			L		
7.2	Multi-axis controller right	(dir. 5-6, 7-8)			R		
9	Gate open-shaped	for open shifting switching sequence 1-0-1 to 3-0-3			P		
10	Gate cross-shaped	(prohibits diagonal shifting)			PX		
11	Gate special-shaped	(e.g. H-gate)					
20	Control-handle with knob solid						
21							
22							
23							
24	Control-handle with push-button			50	D		
25							
30	without switching sequence						
31							
32							
33							
34							
35							
36	switching sequence 4-0-4						
38	Spring return in 0-position (included in the spindle block)				Z		
40	Mechanical encoder with mounted direction 1-2 and 3-4 each 1 encoder life 3 x 10 ⁶ switching cycles 0,5 Watt wiper current max. 1 mA with solder or plug terminal						
44	Mechanical encoder MEC 2-1 male connector EA/15-10 contact-arrangement MS 224-0 see catalog 5/001 Conductive-plastic potentiometer with centre tap linear resistance 2 x 5 kOhm		C 70	15	C		
45	Mechanical encoder MEC 2-2 male connector EA / 11-10 contact-arrangement MS 24-0 see catalog 5/001 Conductive-plastic potentiometer with centre tap linear resistance 2 x 5 kOhm		C 71	15	C		
50	Cover housing KBQ 905 (IP65)						
52	Housing see catalog 1/350						
60	Indicating labels not engraved with 2 or 4 arrows						
61	Engraving, each 10 characters						
70	Command and indicating devices see catalog 1/360						



Degree of Protection front IP 65

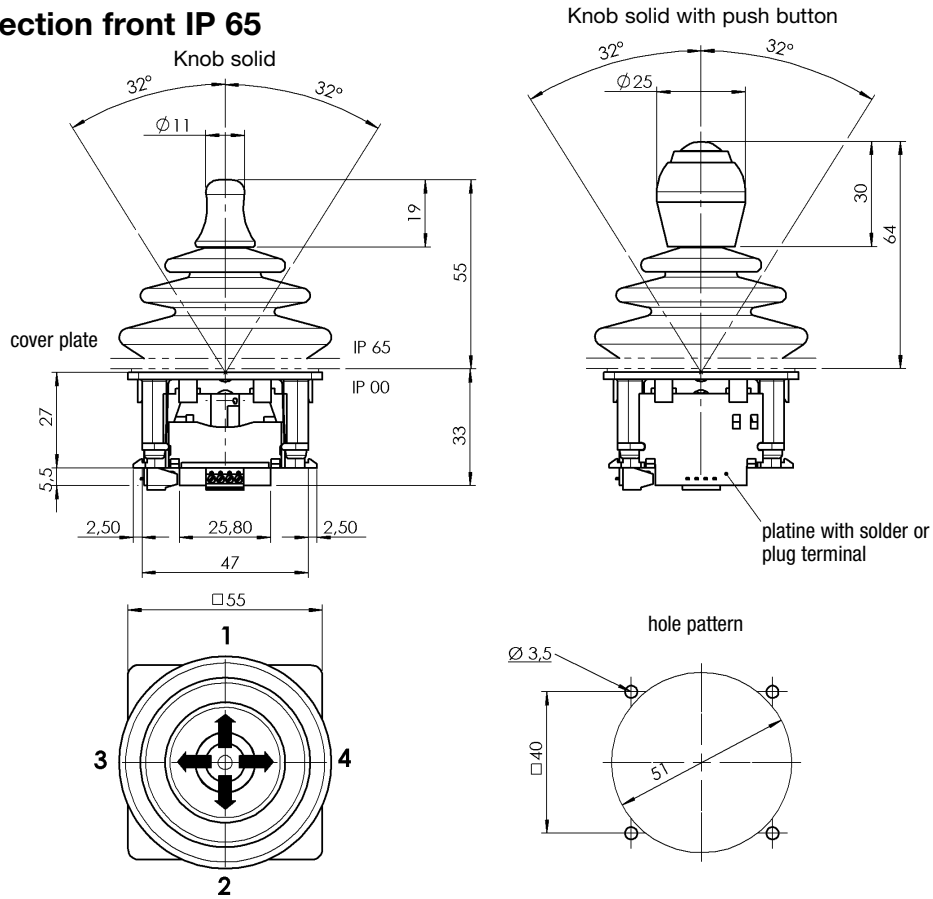

Degree of Protection front IP 67

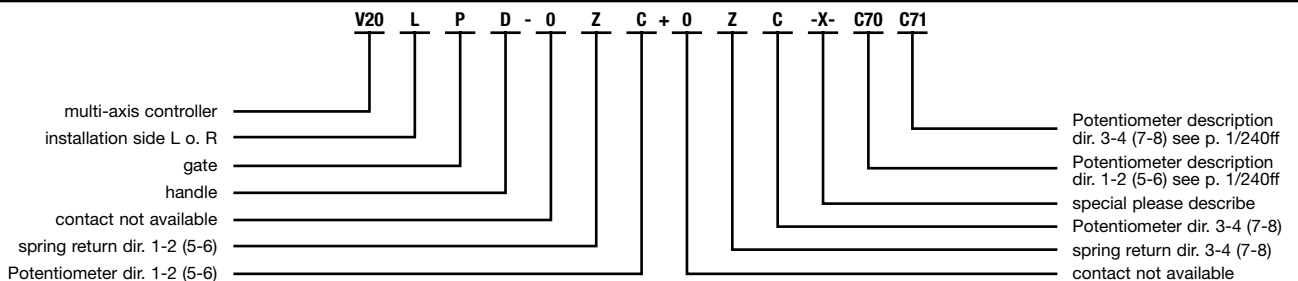
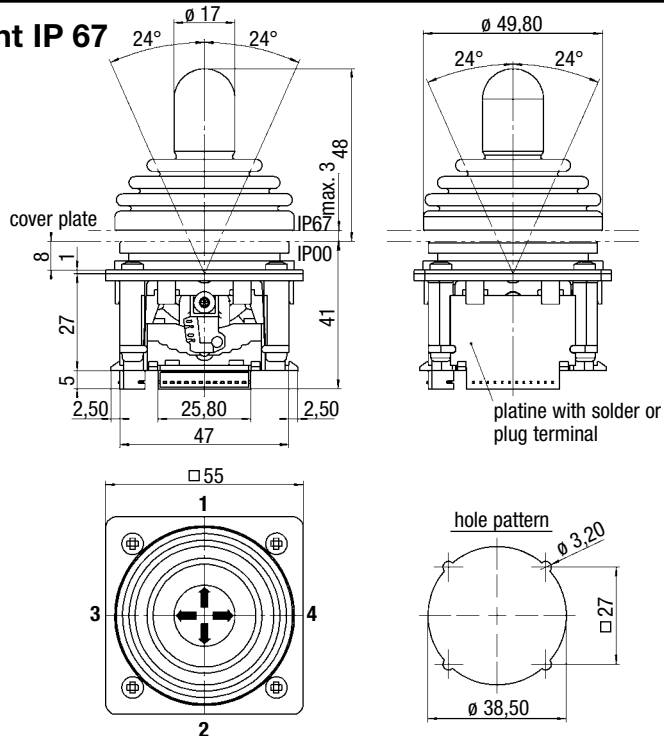



Type V21

The Multi-axis controller V 21 is a rugged switching device according IEC 947-5-1 EN 60947 DIN VDE 0660-200 for electro-hydraulic applications. The V 21 is resistant to oil, maritime climate, ozone and UV radiation. The V 21 has a highly flexible single wire 0,1 mm² x 450 mm long.

Mechanical life 6 millionen operating cycles
permissible ambient temperature operation -40° C bis +60° C
storage -50° C bis +80° C

climate resistance
damp heat constant/cyclic DIN IEC 68 part 2-3/30
degree of protection fron IP 67 IEC 529 DIN 40050

spindle block with schematic representation of the controller installation and deflection directions. Version shown for left-hand side installation (right-hand side installation is mirror image)

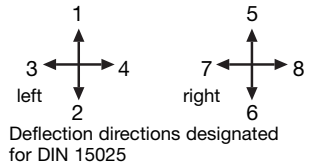

Pos.	V 21.1	V 21	Type-expansion	weight gramm	Type	Price EURO
1				350	V 21.1	
2						
3				350	V 21	
4						
5						
7.1	Multi-axis controller left	(dir. 1-2, 3-4)			L	
7.2	Multi-axis controller right	(dir. 5-6, 7-8)			R	
8	mounting from the top with hexagonal nut (standard)					
8.1	mounting from the top with flange				A	
8.2	mounting from the bottom with flange				B	
10	Gate cross-shaped	(prohibits diagonal shifting)			P	
11	Gate special-shaped				PX	
36	switching sequence 4-0-4					
38	spring return in 0-position	(included in the spindle block)			Z	
40	Setpoint device Magnet for redundant hall sensors	(included in the spindle block)			S	
41	Voltage output impressed 0,5-2,5-4,5 Volt electronic for 1 axis redundante	(counter rotate)	EU 16			
42	electronic for 1 axis redundante	(unidirectional)	EU 18			
42	electronic for 2 axis redundante	(counter rotate)	EO 16			
44	electronic for 2 axis redundante	(unidirectional)	EO 18			
45	Technical data: power supply 4,6-5,5 Volt output 0,5-2,5-4,5 Volt +5 mA output characteristic linear more electronics (Amplifier, Profi-Bus, CAN-Bus) see Catalog 3/150/...		E ...			
52	Housing see Catalog 1/350					
60	Indicating labels not engraved with 2 or 4 arrows					
61	Engraving, each 10 characters					
70	Command and indicating devices see Catalog 1/360					



Standard mounting from the top

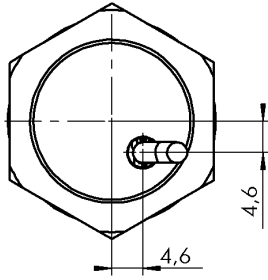

Version A with flange mounting from the top

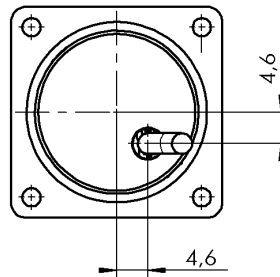

Version B with flange mounting from below

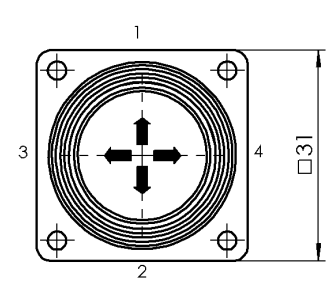
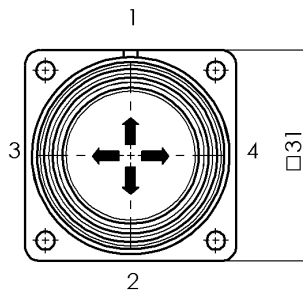
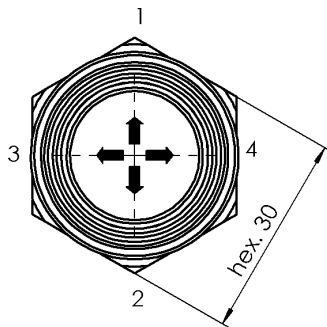
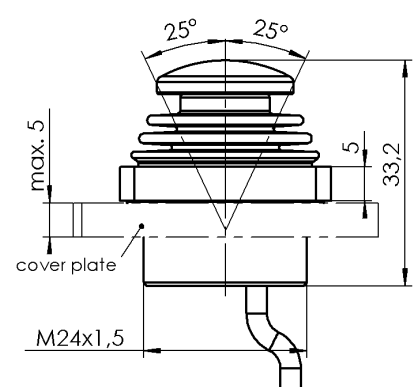
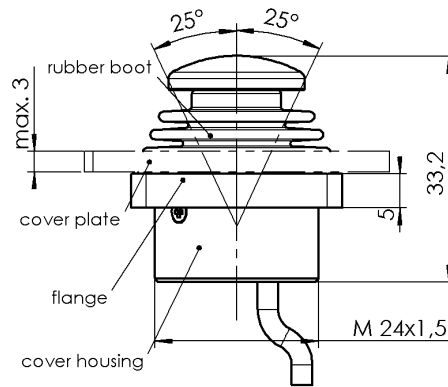
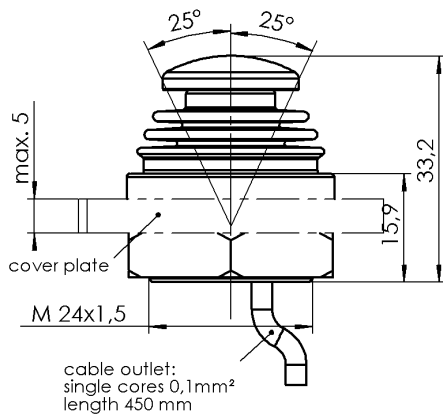
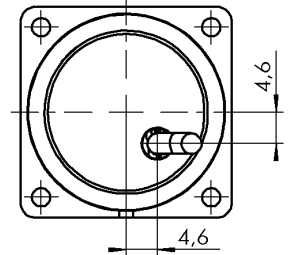

hole pattern

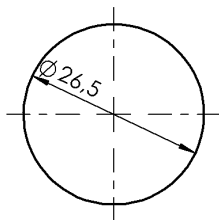

hole pattern

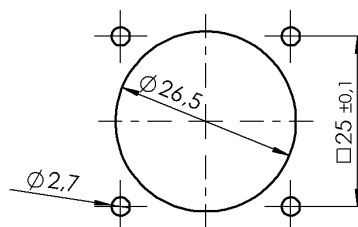

hole pattern

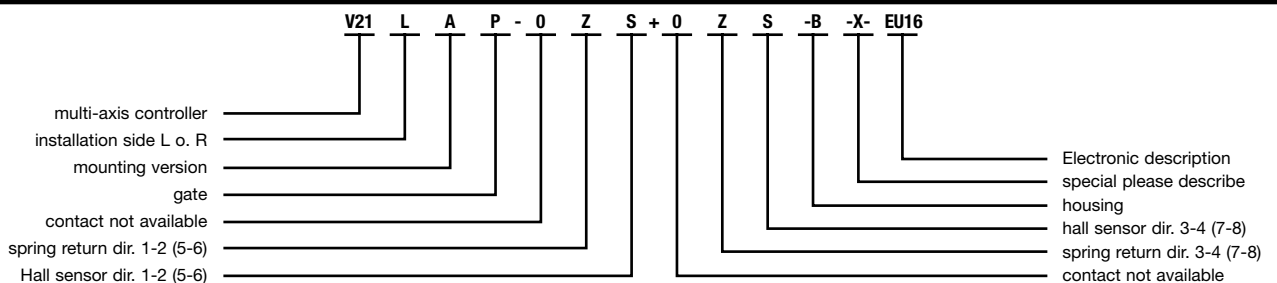
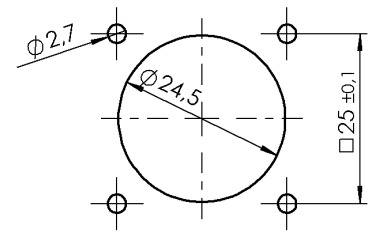



Type V3LT-02Z+02ZP-...

The multi-axis controller V 3 is a rugged switching device according IEC 947-5-1 EN 60947 DIN VDE 0660-200 for hoisting applications. The modular design enables the switching device to be used universally. The V 3 is resistant to oil, maritime climate, ozone and UV radiation.

Contact complement 4 A 250 V AC 15 res. 1 A 24 V DC 13

Mechanical life 6 million (operating cycles)
Permissible ambient temperature Operation -40° C to +60° C
Storage -50° C to +80° C

Climate resistance
Damp heat constant DIN IEC 68 part 2-3
Damp heat cyclic DIN IEC 68 part 2-30
Degree of protection front IP 54 IEC 529 DIN 40050
Technical data see catalog 5/100
Description data see catalog 5/002

Spindle block with schematic representation of the master controller installation and deflection directions.

Version shown for left-hand side installation (right-hand side installation is mirror image).

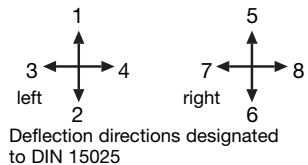

Pos.	V 31	V 3	Type expansion		Weight gramm	Type	Price EURO	
1					940	V 31		
2								
3						1000	V 3	
4								
5								
7.1	Multi-axis controller left	(dir. 1-2, 3-4)				L		
7.2	Multi-axis controller right	(dir. 5-6, 7-8)				R		
10	Gate cross-shaped	(prohibits diagonal shifting)			100	P		
11	Gate special-shaped	(e.g. H-gate)			110	PX		
20	Control-handle with knob solid							
21	Control-handle with latch for mechanical zero interlock by lifting				50	M		
21.1								
21.4	Mechanical zero interlock with command devices see catalog 1/282							
22	Control-handle with dead man's button 1 NO				100	T		
23	Control-handle with signal button 1 NO				100	H		
24	Control-handle with push button 1 NO				110	D		
25	Control-handle with flat push button 1 NO				110	DV		
26	Control-handle with palm grip B 1				40	B 1		
27	Control-handle with palm grip B 1 with push button top 1 NO				60	B 1T		
28	Control-handle long or short							
28.1		-20 mm				S5		
28.2		+20 mm				S8		
29	More knobs, grips and T-grips with and without signal devices see catalog 1/280...							
30	Masterswitch (contact) switching sequenc 4-0-4			No. of contacts 2	290	01		
31				4	350	02		
32	Direction 1-2 and 3-4 each 1 masterswitch			6	410	03		
33	Switching program according contact-arrangement MS... see catalog 5/001 or to your contact-arrangement		A...	8	470	04		
34				10	530	05		
35				12	590	06		
36	Switching sequence 5-0-5							
38	Spring return in 0-position (for each direction)				110	Z		
39	Friction brake adjustable (for each direction)				50	R		
40	Potentiometer e.t.c. each masterswitch with mounted Wire-wound potentiometer T 130, with centre tap, 1,5 Watt wiper current max. 10 mA resistance 2 x 0,5k \cong P021, 2 x 1k \cong P022, 2 x 2k \cong P023, 2 x 5k \cong P024, 2 x 10k \cong P025		...P02 \square		70	P		
41	Prepared for mounting potentiometer shaft 6 mm adjusting-angle 2 x 150°		P...			(P)		
42	Prepared for mounting potentiometer e.t.c. adjusting-angle variable.					(P)		
43	more Potentiometer e.t.c. see catalog 1/240...							
50	Steel sheet housing B 200 masterswitch max. size 04				1300	B		
51	Steel sheet housing B 230 masterswitch max. size 06				1400	B		
52	More housing see catalog 1/350							
60	Indicating labels not engraved with 2 or 4 arrows							
61	Engraving, each 10 characters							
70	Command and indicating devices see catalog 1/360							



T = dead man's button
H = signal button
M = latch for mechanical zero interlock

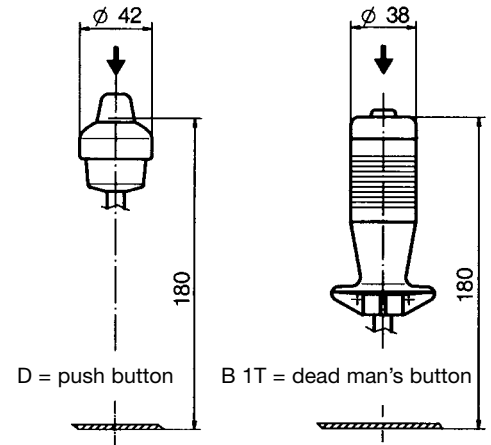
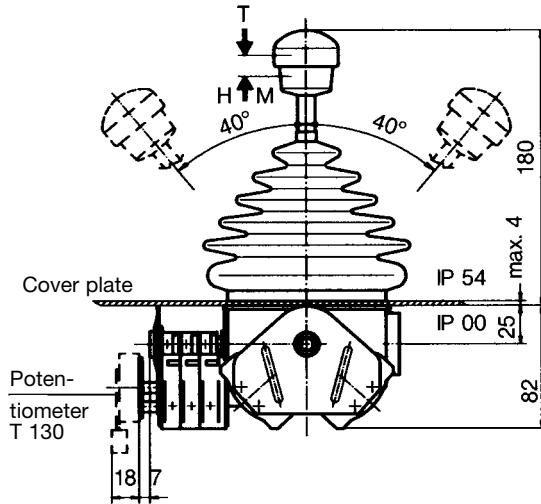

Type	No. of contacts	Dimension B
01	2	77
02	4	89
03	6	102
04	8	114
05	10	127
06	12	139

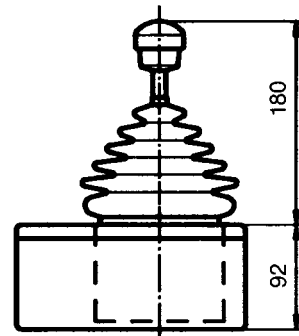
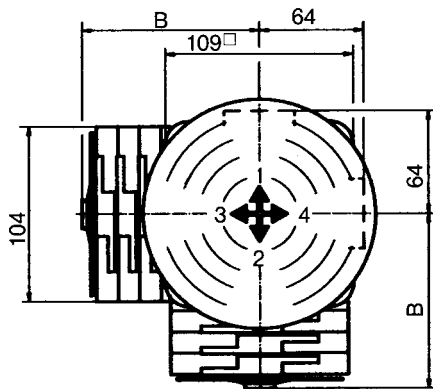

Steel sheet housing

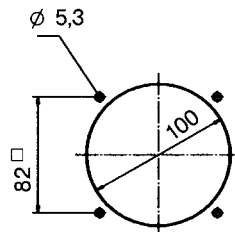

Hole pattern

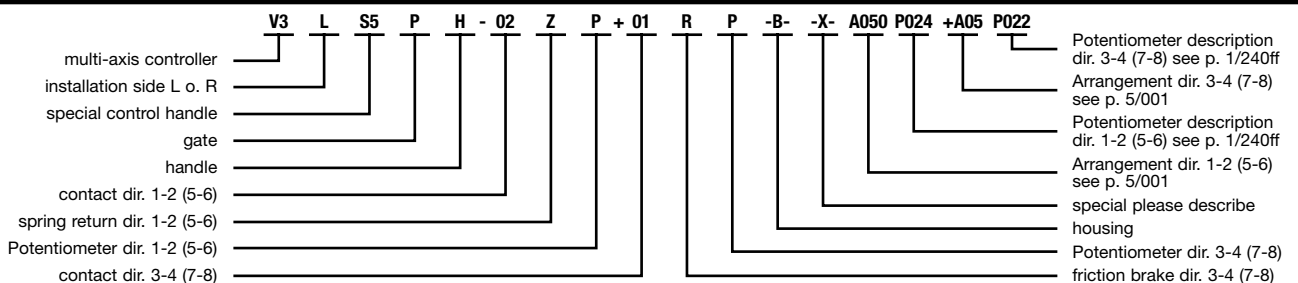
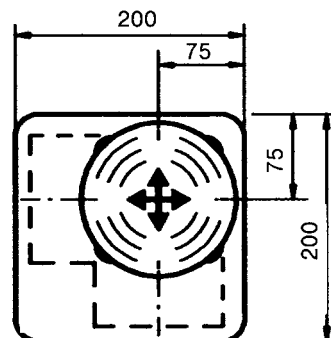



Type V18L-02ZC+02ZC-...

The multi-axis controller V 18 is a rugged switching device according IEC 947-5-1 EN 60947 DIN VDE 0660-200 for hoisting applications. The modular design enables the switching device to be used universally. The V 18 is resistant to oil, maritime climate, ozone and UV radiation. The modular micro changeover contacts are positive opening to VDE 0113.

Contact complement 2 A 250 V AC 15 res. 3 A 24 V DC 13

Mechanical life 20 million (operating cycles)
Permissible ambient temperature Operation -40° C to +60° C
Storage -50° C to +80° C

Climate resistance
Damp heat constant DIN IEC 68 part 2-3
Damp heat cyclic DIN IEC 68 part 2-30
Degree of protection front IP 54 IEC 529 DIN 40050
Technical data see catalog 5/100
Description data see catalog 5/002

Spindle block with schematic representation of the master controller installation and deflection directions.
Version shown for left-hand side installation (right-hand side installation is mirror image).

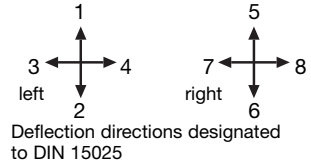

Pos.	V 181	V 18	Type expansion		Weight gramm	Type	Price EURO	
1					2800	V 181		
2								
3					3500	V 18		
4								
5								
7.1	Multi-axis controller left	(dir. 1-2, 3-4)				L		
7.2	Multi-axis controller right	(dir. 5-6, 7-8)				R		
10								
11								
12								
13								
20	Control-handle							
21								
22								
23								
30	Masterswitch (contact) switching sequenc 2-0-2			No. of contacts 2	290	01		
31				4	350	02		
32	Direction 1-2 and 3-4 each 1 masterswitch			6	410	03		
33	Switching program according contact-arrangement MS... see catalog 5/001		A...					
34	or to your contact-arrangement							
35								
36								
37								
38	Spring return in 0-position	(for each direction)			110	Z		
39	Friction brake adjustable	(for each direction)			30	R		
40	Potentiometer e.t.c. each masterswitch with mounted Wire-wound potentiometer T 130, with centre tap, 1,5 Watt wiper current max. 10 mA resistance 2 x 0,5k ≙ P021, 2 x 1k ≙ P022, 2 x 2k ≙ P023, 2 x 5k ≙ P024, 2 x 10k ≙ P025		...P02 □		70	P		
41	Prepared for mounting potentiometer shaft 6 mm adjusting-angle 2 x 150°				300	(P)		
42	Prepared for mounting potentiometer e.t.c. adjusting-angle variable.				300	(P)		
43	more Potentiometer e.t.c. see catalog 1/240...		C..., P...					
50								
51								
52								
53								
60	Indicating labels not engraved with 2 or 4 arrows							
61	Engraving, each 10 characters							
62								
70								

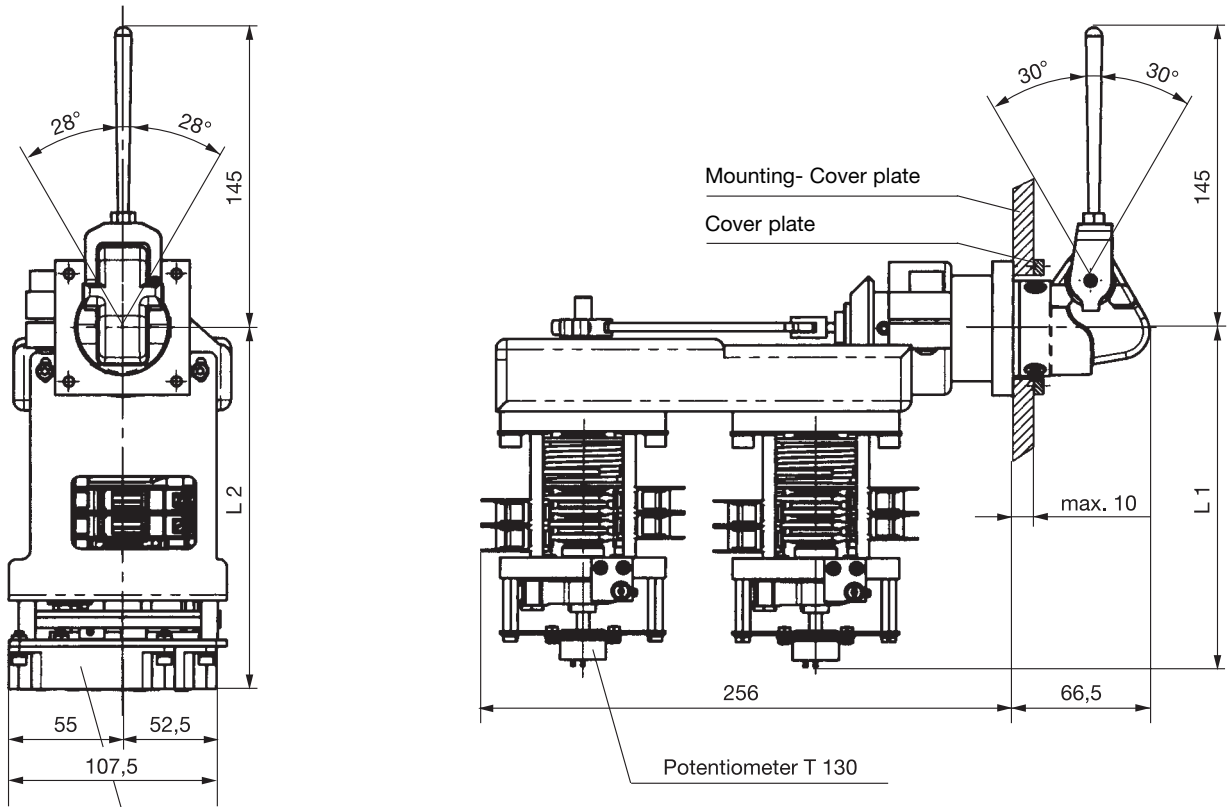

Opto-electronic encoder OEC 2

Type	No. of contacts	Dimension L1	Dimension L2
01	2	151,0	163,0
02	4	163,5	175,5
03	6	176,0	188,0

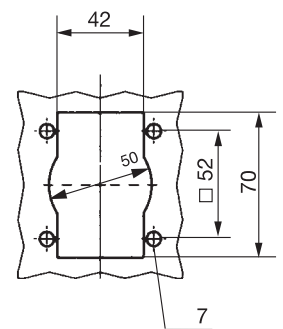

Hole pattern

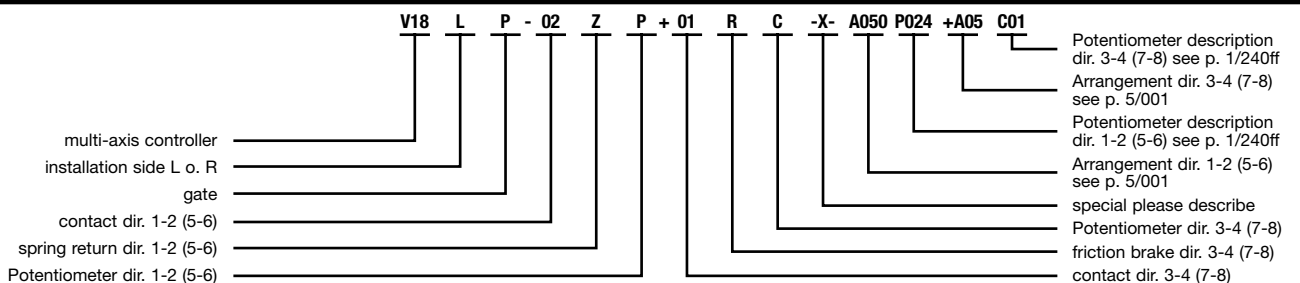

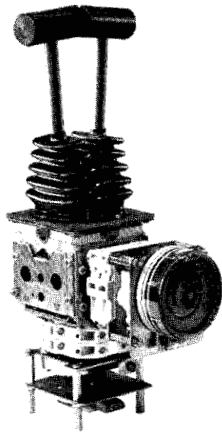

Type D64LQQ-02ZP+02ZP-...

The double-handle controller is a rugged switching device according IEC 947-5-1 EN 60947 DIN VDE 0660-200 for hoisting applications. The modular design enables the switching device to be used universally. The D 64 is resistant to oil, maritime climate, ozone and UV radiation.

**Contact complement 2 A 250 V AC 15 res. 1 A 24 V DC 13 (standard)
or 4 A 250 V AC 15 (special)**

Mechanical life D 64 10 million (operating cycles)
Mechanical life DD 64 20 million (operating cycles)
Permissible ambient temperature Operation -40° C to +60° C
Storage -50° C to +80° C

Climate resistance
Damp heat constant DIN IEC 68 part 2-3
Damp heat cyclic DIN IEC 68 part 2-30
Degree of protection front IP 54 IEC 529 DIN 40050
Technical data see catalog 5/100
Description data see catalog 5/002

Spindle block with schematic representation of the master controller installation and deflection directions.
Version shown for left-hand side installation (right-hand side installation is mirror image).

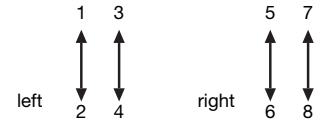

Deflection directions designated to DIN 15025

Pos.	D 64	DD 64	Type expansion		Weight gramm	Type	Price EURO	
1								
2								
3						1100	D 64	
4						1100	DD64	
5								
7.1	Double-handle controller left	(dir. 1-2, 3-4)				L		
7.2	Double-handle controller right	(dir. 5-6, 7-8)				R		
10								
20	Control-handle with knob solid			(for each direction for Pos. 20-28)				
21	Control-handle with latch for mechanical zero interlock							
21.1	by lifting				50	M		
21.2	by lifting, interlocking the gate or the joint bracket				60	MP		
21.3	by pushing down				50	MN		
21.4	Mechanical zero interlock with command devices see catalog 1/282							
22	Control-handle with dead man's button 1 NO				100	T		
23	Control-handle with signal button 1 NO				100	H		
24	Control-handle with push button 1 NO				110	D		
25	Control-handle with flat push button 1 NO				110	DV		
26	Control-handle with T-grip			40	Q			
27	Control-handle with T-grip and push button side 1 NO			60	QD			
28	Control-handle long or short							
28.1		-20 mm				S5		
28.2		+20 mm				S8		
29	More knobs, grips and T-grips with and without signal devices see catalog 1/280...							
30	Masterswitch (contact set) switching sequenc 4-0-4			No. of contacts	2	01		
31					4	02		
32	Direction 1-2 and 3-4 each 1 masterswitch				6	03		
33	Switching program according contact-arrangement MS... see catalog 5/001		A...		8	04		
34	or to your contact-arrangement				10	05		
35					12	06		
36	Switching sequence 5-0-5 or 6-0-6							
38	Spring return in 0-position (for each direction)				110	Z		
39	Friction brake adjustable (for each direction)				30	R		
40	Potentiometer e.t.c. each masterswitch with mounted Wire-wound potentiometer T 130, with centre tap, 1,5 Watt wiper current max. 10 mA resistance 2 x 0,5k \triangle P021, 2 x 1k \triangle P022, 2 x 2k \triangle P023, 2 x 5k \triangle P024, 2 x 10k \triangle P025		...P02 \square		70	P		
41	Prepared for mounting potentiometer shaft 6 mm adjusting-angle 2 x 150°					(P)		
42	Prepared for mounting potentiometer e.t.c. adjusting-angle variable.					(P)		
43	more Potentiometer e.t.c. see catalog 1/240...		C..., P...					
52	More housing see catalog 1/350							
60	Indicating labels not engraved with 2 or 4 arrows							
61	Engraving, each 10 characters							
70	Command and indicating devices see catalog 1/360							



T = dead man's button
H = signal button
M = latch for mechanical zero interlock

Knob solid
D = -push button

T-grip
D = -push button

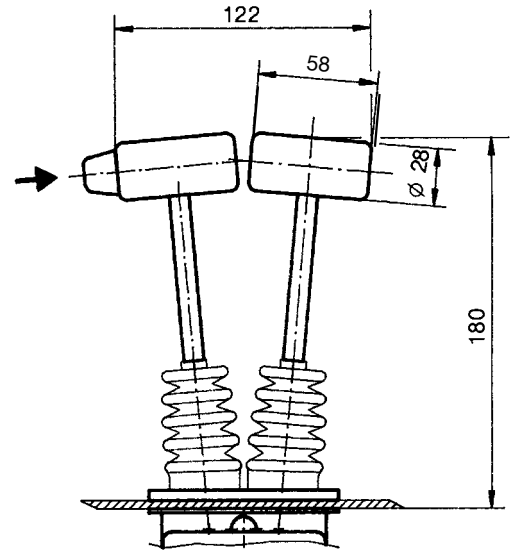
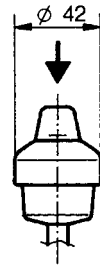
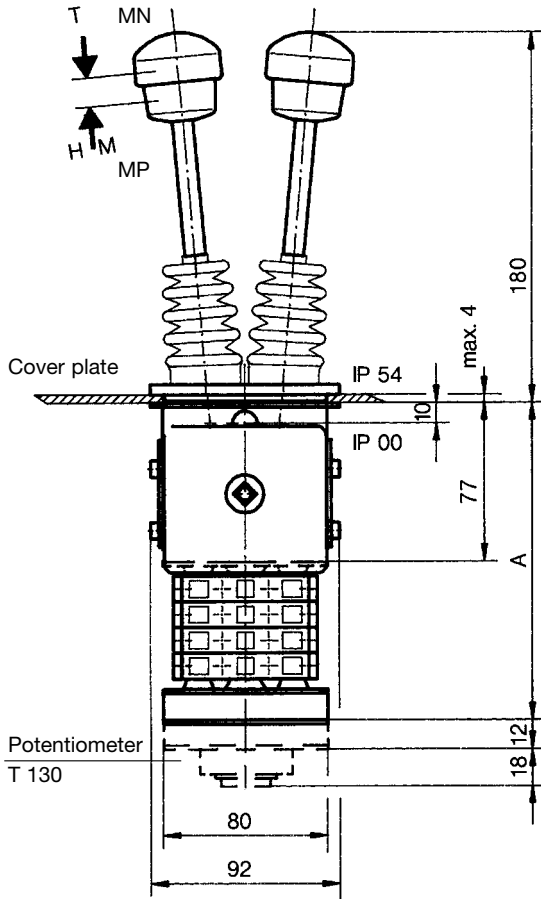

To build in:
direction 1-2
direction 3-4

Type	No. of contacts	Dimension A	Dimension B
01	2	119	82
02	4	131	94
03	6	144	107
04	8	156	119
05	10	169	132
06	12	181	144

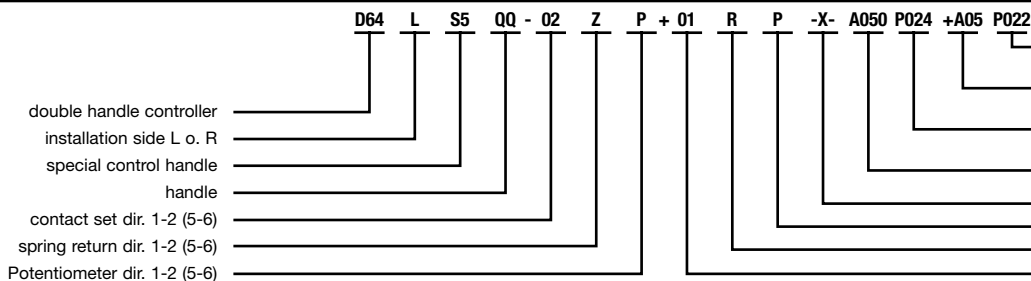
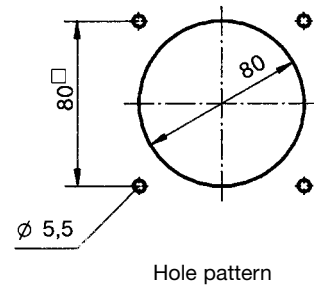
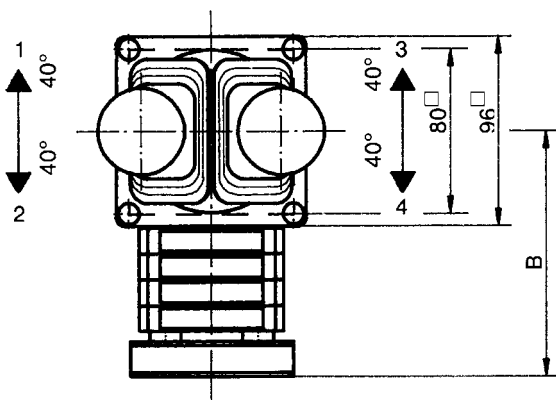

Potentiometer description dir. 3-4 (7-8) see p. 1/240ff
Arrangement dir. 3-4 (7-8) see p. 5/001
Potentiometer description dir. 1-2 (5-6) see p. 1/240ff
Arrangement dir. 1-2 (5-6) see p. 5/001
special please describe
Potentiometer dir. 3-4 (7-8)
friction brake dir. 3-4 (7-8)
contact set dir. 3-4 (7-8)

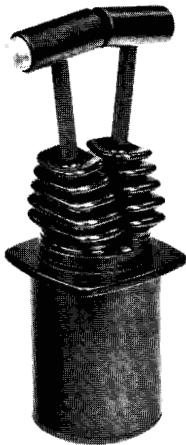

Type D8LQQD-2ZP+2ZP-B...

The double-handle controller D 8 is a rugged switching device according IEC 947-5-1 EN 60947 DIN VDE 0660-200 for electro-hydraulic applications. The modular design enables the switching device to be used universally. The D 8 is resistant to oil, maritime climate, ozone and UV radiation.

Contact complement 0,5 A 110 V AC 15 res. 1,5 A 24 V DC 13
I min > 0,2 mA 2 V DC 12 Gold plated for max. load of 0,12 Watt (standard)
or I max < 300 mA 0,4 V DC 12 max. capacity 0,12 Watt do not exceed!
I min >0,2 mA 2 V DC 12 max. contact reliability for very low current (special)

Mechanical life 8 million (operating cycles)
 Permissible ambient temperature Operation -40° C to +60° C
 Storage -50° C to +80° C

Climate resistance
 Damp heat constant DIN IEC 68 part 2-3
 Damp heat cyclic DIN IEC 68 part 2-30
 Degree of protection front IP 54 IEC 529 DIN 40050
 Technical data see catalog 5/100
 Description data see catalog 5/002

Spindle block with schematic representation of the master controller installation and deflection directions.
 Version shown for left-hand side installation (right-hand side installation is mirror image).



Deflection directions designated to DIN 15025

Pos.	D 8	Type expansion	Weight gramm	Type	Price EURO
1					
2					
3			1000	D 8	
4					
5					
7.1	Double-handle controller left (dir. 1-2, 3-4)			L	
7.2	Double-handle controller right (dir. 5-6, 7-8)			R	
10					
20	Control-handle with knob solid	(for each direction for Pos. 20-28)			
21	Control-handle with latch for mechanical zero interlock by lifting		50	M	
22	Control-handle with dead man's button 1 NO		100	T	
23	Control-handle with signal button 1 NO		100	H	
24	Control-handle with push button 1 NO		110	D	
25	Control-handle with flat push button 1 NO		110	DV	
26	Control-handle with T-grip		40	Q	
27	Control-handle with T-grip and push button side 1 NO		60	QD	
28	Control-handle long or short				
28.1	-20 mm			S5	
28.2	+20 mm		S8		
29	More knobs, grips and T-grips with and without signal devices see catalog 1/280...				
30	Masterswitch (contact) switching sequenc -0-	A...	No. of contacts 1	20	1
31			2	40	2
32	Direction 1-2 and 3-4 each 1 masterswitch		3	60	3
33	Switching program according contact-arrangement MS... see catalog 5/001				
34	or to your contact-arrangement				
36	Switching sequence 3-0-3				
38	Spring return in 0-position (for each direction)		30	Z	
39	Friction brake adjustable (for each direction)		30	R	
40	Potentiometer e.t.c. each masterswitch with mounted Conductive-plastic potentiometer T 301, with centre tap linear 0,5 Watt wiper current max. 1 mA resistance 2 x 1k \pm P182, 2 x 5k \pm P184	...P18 \square	70	P	
41	Prepared for mounting potentiometer shaft 6 mm adjusting-angle 2 x 120°	P...		(P)	
42	Prepared for mounting potentiometer e.t.c. adjusting-angle variable.			(P)	
43	more Potentiometer e.t.c. see catalog 1/240...				
45	Electronic (Amplifier, Profi-Bus, CAN-Bus) see catalog 3/510/...	E...			
50	Cover housing		300	B	
51	Filter plug M 20 for air-condition		20		
52	Cable entry M 20 with anti-kink protection and strain relief		30		
53	Plug in socket 14-pole female insert CPC 17 wired		150		
54	Connector 14-pole male insert CPC 17 unwired		150		
55	Wiring plug in socket or connector each wired-connection				
60	Indicating labels not engraved with 2 or 4 arrows				
61	Engraving, each 10 characters				



T = dead man's button
H = signal button
M = latch for mechanical zero interlock

Knob solid

D = push button

T-grip

D = push button

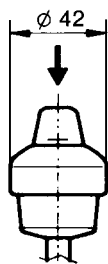
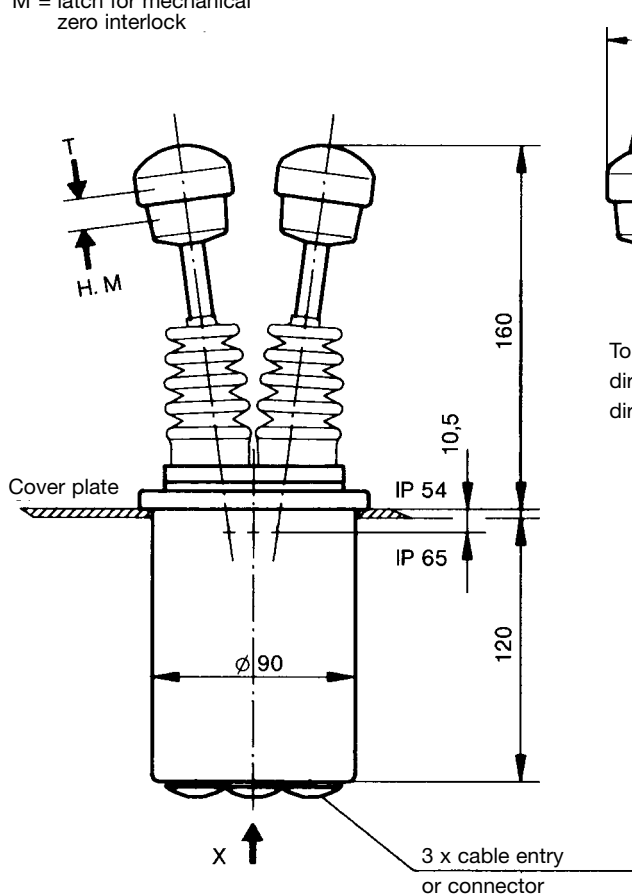

To build in:
direction 1-2
direction 3-4

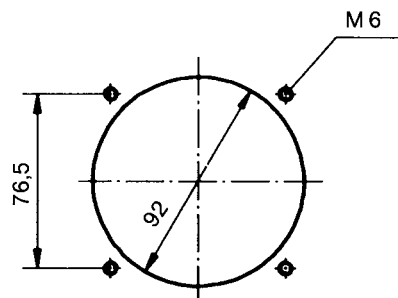
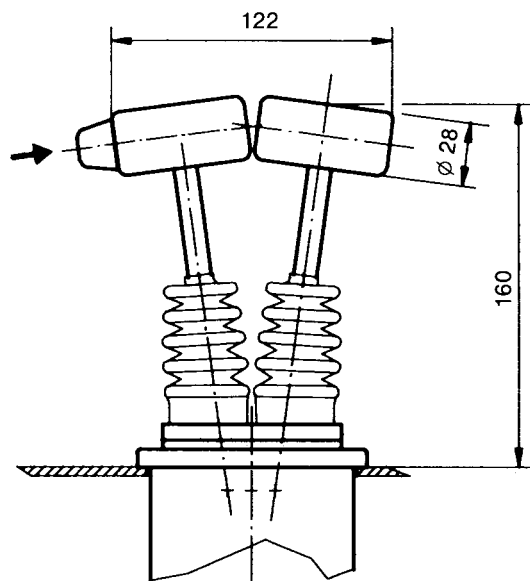

Hole pattern

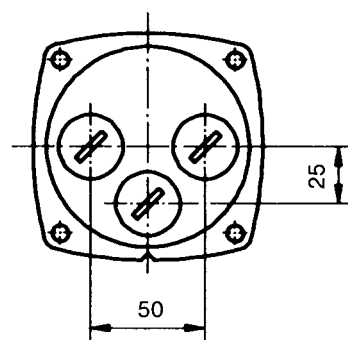
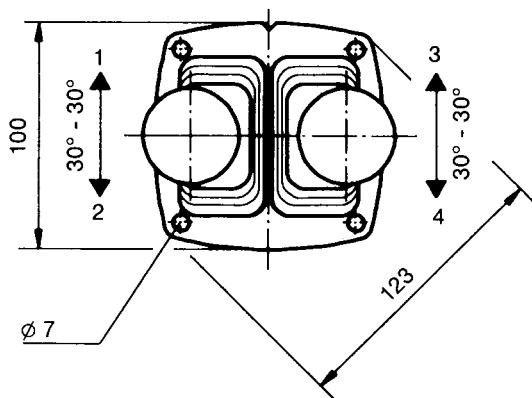

View x

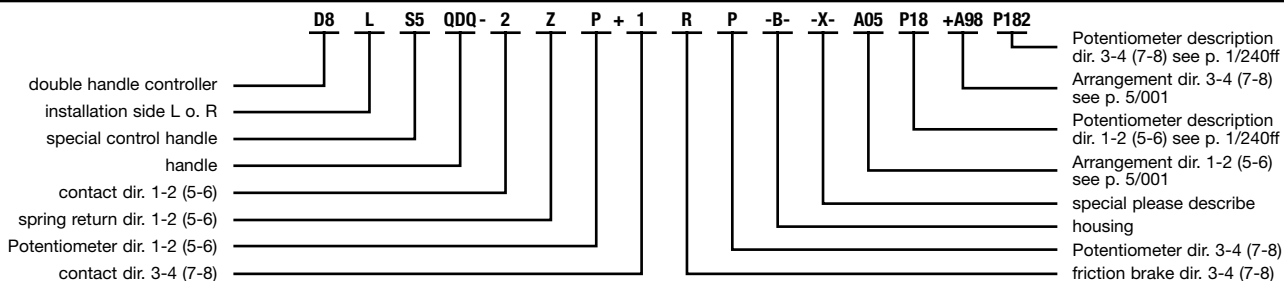



Type D3LQQ-2ZP+2ZP-B...

The double-handle controller D 3 is a rugged switching device according IEC 947-5-1 EN 60947 DIN VDE 0660-200 for nautical navigation applications. The modular design enables the switching device to be used universally. The D 3 is resistant to oil, maritime climate, ozone and UV radiation.

Contact complement 0,5 A 110 V AC 15 res. 1,5 A 24 V DC 13
I min > 0,2 mA 2 V DC 12 Gold plated for max. load of 0,12 Watt (standard)

Mechanical life	12 million (operating cycles)
Permissible ambient temperature	Operation -40° C to +60° C Storage -50° C to +80° C
Climate resistance	
Damp heat constant	DIN IEC 68 part 2-3
Damp heat cyclic	DIN IEC 68 part 2-30
Degree of protection front	IP 66 IEC 529 DIN 40050
Technical data see catalog 5/100	
Description data see catalog 5/002	

Spindle block with schematic representation of the master controller installation and deflection directions.
Version shown for left-hand side installation (right-hand side installation is mirror image).



Deflection directions designated to DIN 15025

Pos.	D 3	Type expansion		Weight gramm	Type	Price EURO
1						
2						
3				4000	D 3	
4						
5						
7.1	Double-handle controller left (dir. 1-2, 3-4)				L	
7.2	Double-handle controller right (dir. 5-6, 7-8)				R	
10						
20	Control-handle with knob solid					
21						
22						
23						
24	Control-handle with push button 1 NO			110	D	
25						
26	Control-handle with T-grip			40	Q	
27	Control-handle with T-grip and push button side 1 NO			60	QD	
28	Control-handle long or short					
28.1	-20 mm				S5	
28.2	+20 mm				S8	
29						
30	Masterswitch (contact) switching sequenc -0-		No. of contacts	20	1	
31			1	40	2	
32	Direction 1-2 and 3-4 each 1 masterswitch		2	60	3	
33	Switching program according contact-arrangement MS... see catalog 5/001	A...	3			
34	or to your contact-arrangement					
35						
36	Switching sequence special					
38	Spring return in 0-position (for each direction)			30	Z	
39	Friction brake adjustable (for each direction)			30	R	
40	Potentiometer e.t.c. each masterswitch with mounted Conductive-plastic potentiometer T 246, with centre tap linear 0,5 Watt wiper current max. 1 mA, resistance 2 x 5k \cong P214	...P21 \square		70	P	
41	Prepared for mounting potentiometer shaft 6 mm adjusting-angle 2 x 75°				(P)	
42	Prepared for mounting potentiometer e.t.c. adjusting-angle variable.				(P)	
43	more Potentiometer e.t.c. see catalog 1/240...	P...				
50	Cover housing			300	B	
51	Filter plug M 20 for air-condition			20		
52	Cable entry M 32 with anti-kink protection			30		
60	Indicating label eloxal aluminium plate silvery (included in the spindle block)					
61	Engraving, each 10 characters					



T-grip

D = push button

Direction 1-2 Direction 3-4

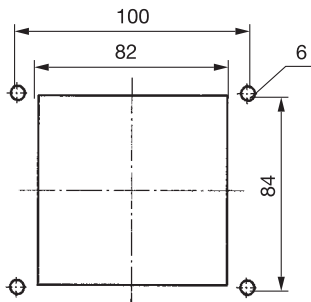
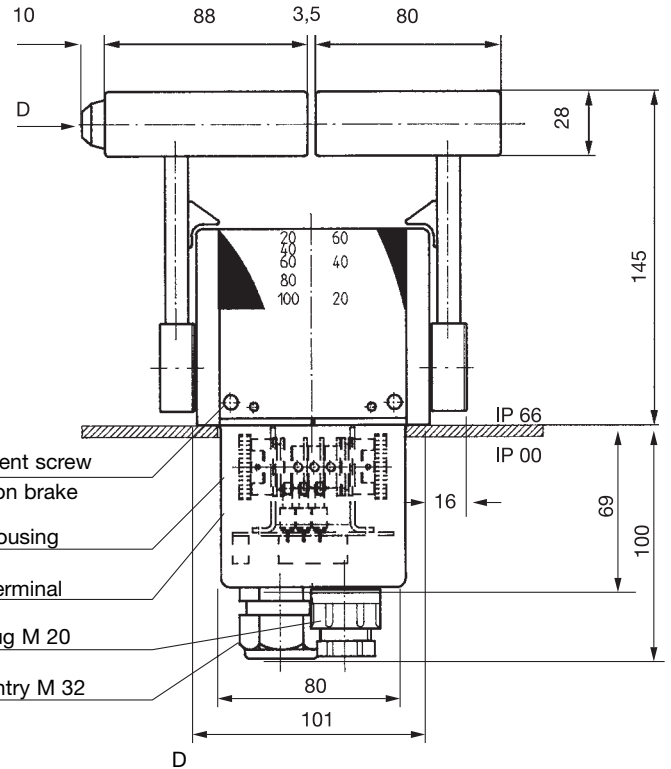
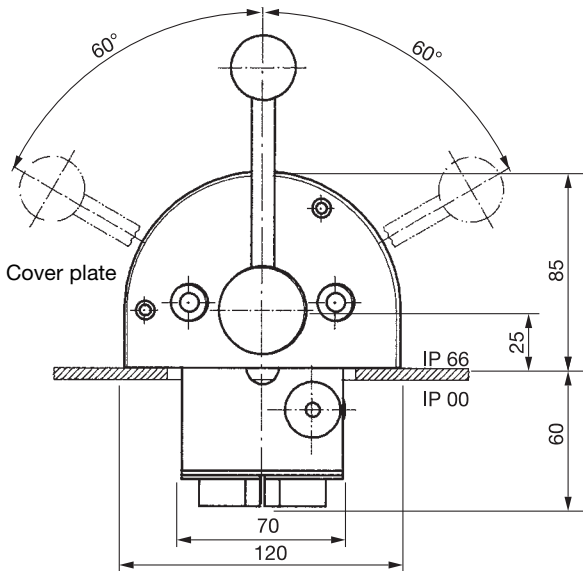

Hole pattern

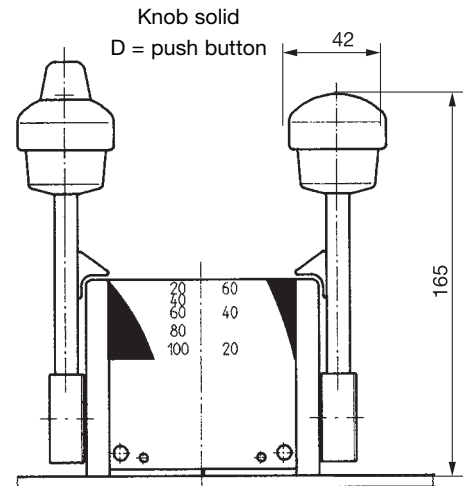

Knob solid

D = push button

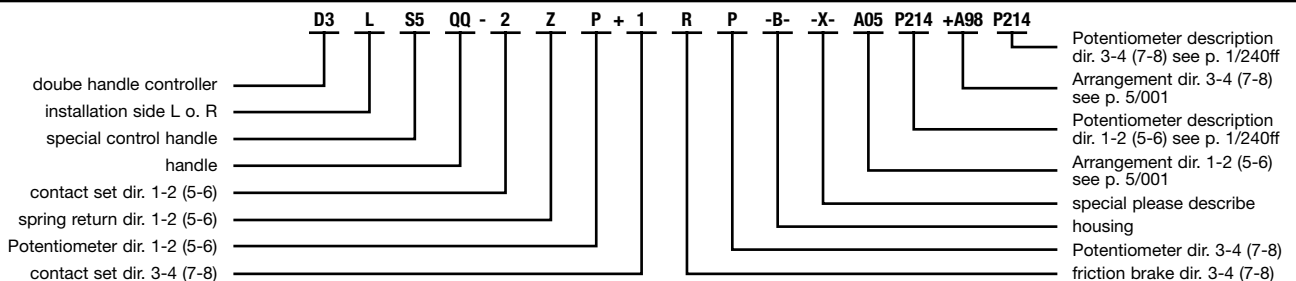



Type S1LGS8-00ZP-...

Type S1LGK4-00ZP-...

The single-axis controller S 1 is a rugged switching device according IEC 947-5-1 EN 60947 DIN VDE 0660-200 for remote control and electro-hydraulic applications. The S 1 is resistant to oil, maritime climate, ozone and UV radiation.

Contact complement 0,5 A 110 V AC 15 res. 1,5 A 24 V DC 13
I min > 0,2 mA 2 V DC 12 Gold plated for max. load of 0,12 Watt (standard)

Mechanical life 6 million (operating cycles)
Permissible ambient temperature Operation -40° C to +60° C
Storage -50° C to +80° C

Climate resistance
Damp heat constant DIN IEC 68 part 2-3
Damp heat cyclic DIN IEC 68 part 2-30
Degree of protection front IP 65 IEC 529 DIN 40050
Technical data see catalog 5/100
Description data see catalog 5/002

Spindle block with schematic representation of the master controller installation and deflection directions.

Version shown for left-hand side installation (right-hand side installation is mirror image).

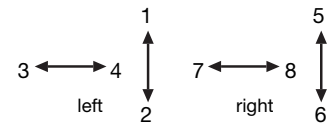

Deflection directions designated to DIN 15025

Pos.	S 1	Type expansion		Weight gramm	Type	Price EURO
1				150	S 1	
2						
3						
4						
5						
7.1	Single-axis controller left (dir. 1-2, 3-4)				L	
7.2	Single-axis controller right (dir. 5-6, 7-8)				R	
10						
20	Control-handle with knob solid GK 4					
21	Control-handle with latch for mechanical zero interlock by lifting			50	M	
22	Control-handle with dead man's button 1 NO			80	T	
23						
24	Control-handle with push button 1 NO				D	
25						
26	Control-handle with knob GS 8				GS 8	
30	Masterswitch (contact) switching sequenc -0- Switching program according contact-arrangement MS see catalog 5/001 or to your contact-arrangement	A...	No. of contacts 2 4	20 40	01 02	
36	switching sequence 2-0-2					
38	Spring return in 0-position (for each direction)				Z	
39	Friction brake adjustable (for each direction)				R	
44	Potentiometer e.t.c. each masterswitch with mounted Conductive-plastic potentiometer T 375, with centre tap linear life 10 ⁷ switching cycles resistance 2 x 5 kOhm 0,5 Watt wiper current max. 1 mA	...P37 □		20	P	
45	Conductive-plastic potentiometer T 430 with centre tap linear life 10 ⁷ switching cycles resistance 2 x 5 kOhm 2 conductive-plastic-contact way arrangement MSP 21 (catalog 5/001) 0,5 Watt wiper current max. 1 mA	...P27 □		25	P	
52	Housing see catalog 1/350					
60	Indicating labels not engraved with 2 arrows					
61	Engraving, each 10 characters					
70	Command and indicating devices see catalog 1/360					



S 1 with knob solid GK 4

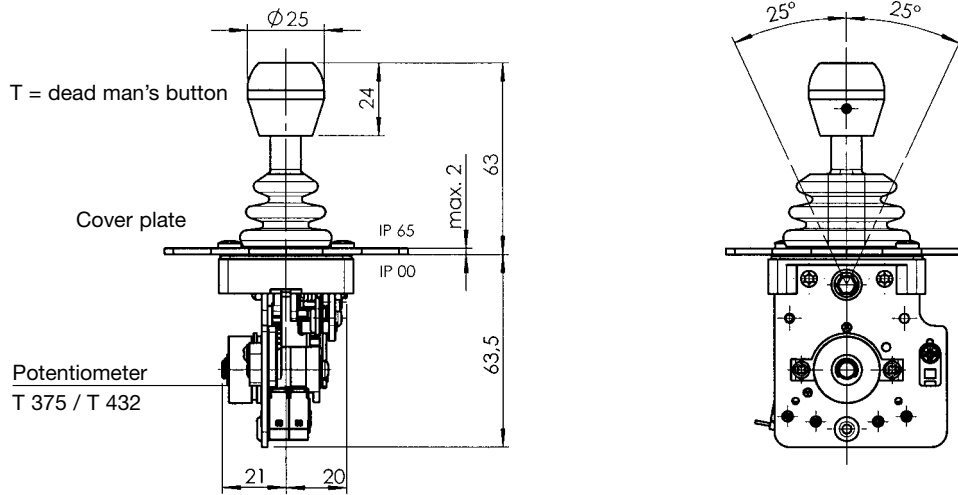

S 1 with knob GS 8

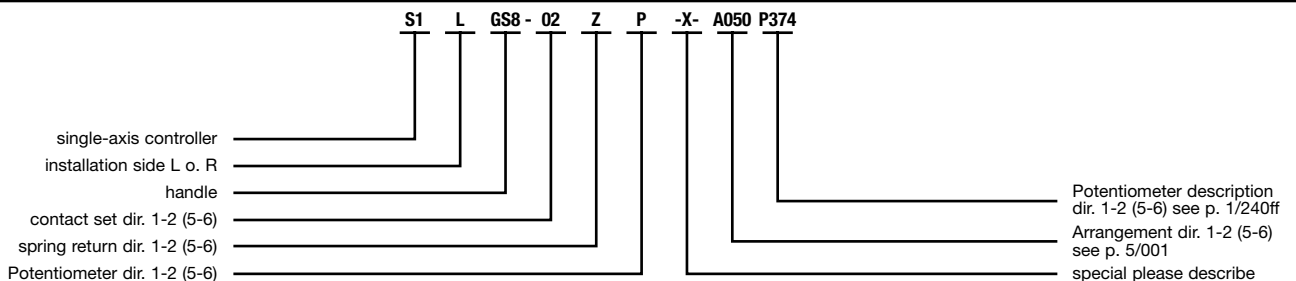
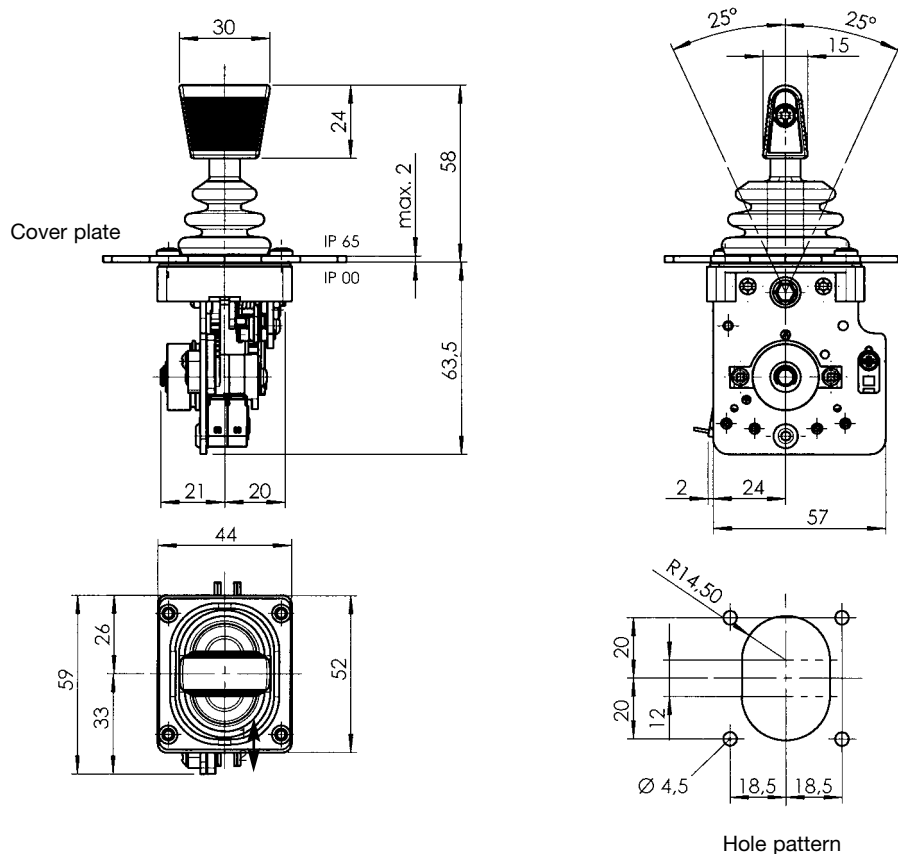



Type S14L-01ZP-...

The single-axis controller S 14 is a rugged switching device according IEC 947-5-1 EN 60947 DIN VDE 0660-200 for remote control and hoisting applications. The S 14 is resistant to oil, maritime climate, ozone and UV radiation.

Contact complement 2 A 250 V AC 15 res. 1 A 24 V DC 13

Mechanical life 6 million (operating cycles)
Permissible ambient temperature Operation -40° C to +60° C
Storage -50° C to +80° C

Climate resistance
Damp heat constant DIN IEC 68 part 2-3
Damp heat cyclic DIN IEC 68 part 2-30
Degree of protection front IP 65 IEC 529 DIN 40050
Technical data see catalog 5/100
Description data see catalog 5/002

Spindle block with schematic representation of the master controller installation and deflection directions. Version shown for left-hand side installation (right-hand side installation is mirror image).

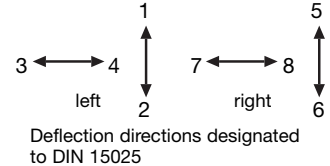

Pos.	S 14	Type expansion		Weight gramm	Type	Price EURO
1				150	S 14	
2						
3						
4						
5						
7.1	Single-axis controller left (dir. 1-2, 3-4)				L	
7.2	Single-axis controller right (dir. 5-6, 7-8)				R	
10						
20	Control-handle with knob solid					
21	Control-handle with latch for mechanical zero interlock					
21.1	by lifting			50	M	
21.2	by lifting, interlocking in the joint bracket			60	MP	
21.3	by pushing down			50	MN	
21.4	Mechanical zero interlock with command devices see catalog 1/282					
22	Control-handle with dead man's button 1 NO			80	T	
23	Control-handle with signal button 1 NO			80	H	
28	Control-handle long +20 mm				S8	
29	More knobs, grips and T-grips with and without signal devices see catalog 1/280...					
30	Masterswitch (contact set) switching sequenc 4-0-4 adjustable (with encoder 6-0-6)		No. of contacts 2	70	01	
31			4	130	02	
32	Direction 1-2 or 3-4		6	190	03	
33	Switching program according contact-arrangement MS... see catalog 5/001	A...				
34	or to your contact-arrangement					
38	Spring return in 0-position (for each direction)				Z	
39	Friction brake adjustable (for each direction)				R	
44	Mechanical encoder with mounted direction 1-2 or 3-4 life 5 x 10 ⁸ switching cycles, 0,5 Watt wiper current max. 1 mA Mechanical encoder MEC 1-2 male connector EA/02-10 contact-arrangement MS 26-0 see catalog 5/001 Conductive-plastic potentiometer with centre tap linear resistance 2 x 10 kOhm	C 61		30	C	
45	Mechanical encoder MEC 1-7 male connector EA / 10-10 contact-arrangement MS 26-0-1 see catalog 5/001 Conductive-plastic potentiometer with centre tap linear resistance 2 x 5 kOhm	C 62		20	C	
46	Mechanical encoder MEC 1-6 male connector EA / 09-10, 6 Bit Gray-Code	C 63		30	C	
47	Mechanical encoder MEC 1-6-5 male connector ER / 36-10 Power supply 24 V DC, output power impressed 4-20 mA	C 64		30	C	
48	Mechanical encoder MEC 1-6-8 male connector ER / 36-12 Power supply 24 V DC, output power impressed 0-20 mA	C 65		30	C	
49	Mechanical encoder MEC 1-10 male connector EA / 17-10 contact-arrangement MS21-0 + MS21 see catalog 5/001 Conductive-plastic potentiometer with centre tap Linear resistance 2 x 1,5 kOhm	C 66		30	C	
52	Housing see catalog 1/350					
60	Indicating labels not engraved with 2 arrows					
61	Engraving, each 10 characters					
70	Command and indicating devices see catalog 1/360					



T = dead man's button
H = signal button
M = latch for mechanical zero interlock

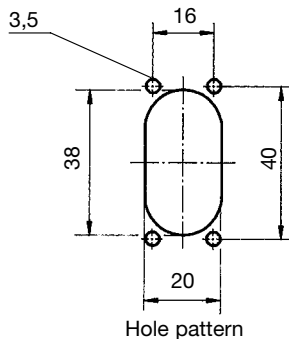
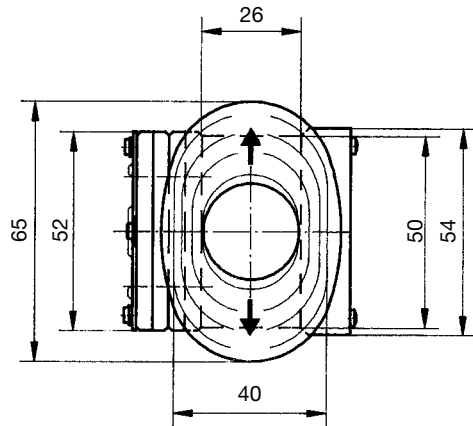
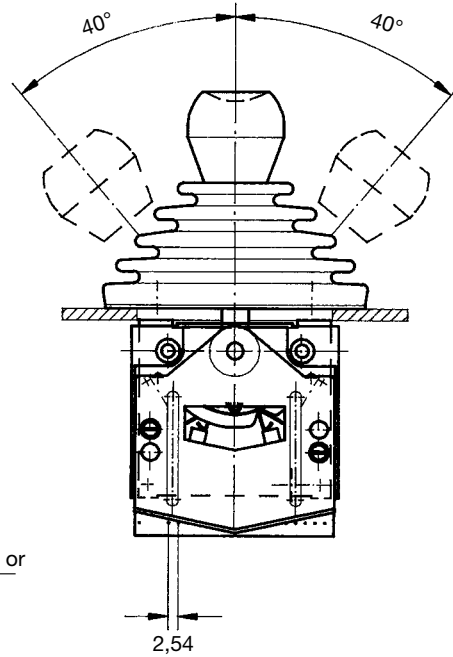
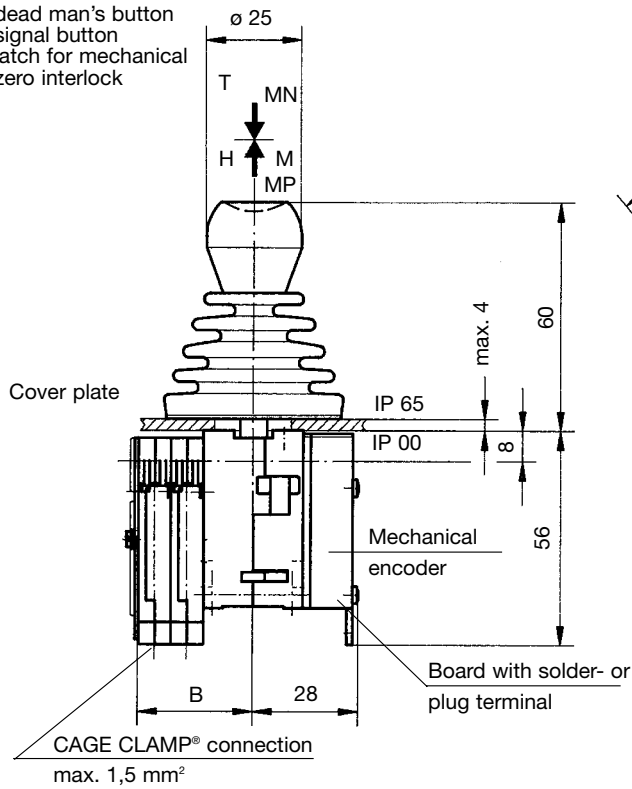

Type	No. of contacts	Dimension B
01	2	24
02	4	33
03	6	42

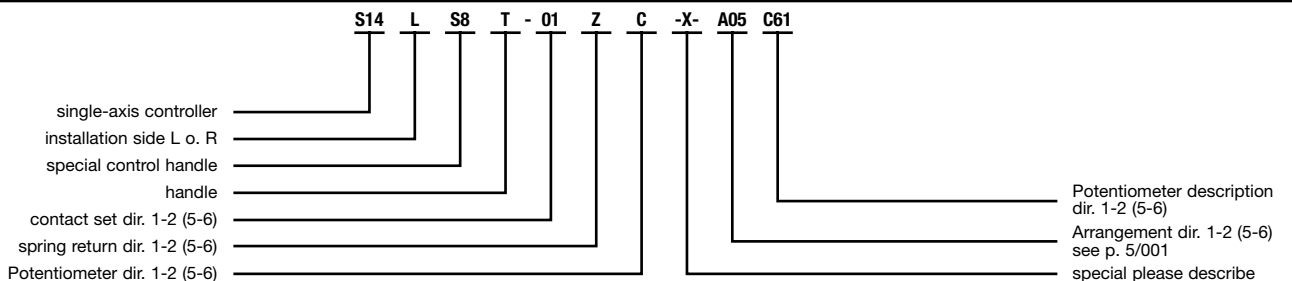

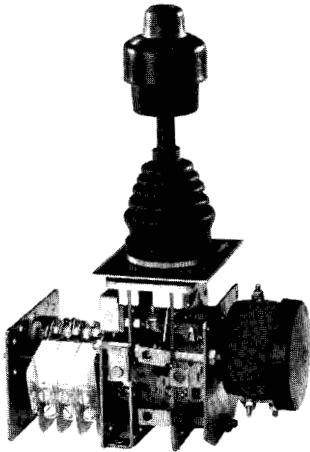

Type S2LD-03ZP-...

The single-axis controller S 2 is a rugged switching device according IEC 947-5-1 EN 60947 DIN VDE 0660-200 for electro-hydraulic applications. The modular design enables the switching device to be used universally. The S 2 is resistant to oil, maritime climate, ozone and UV radiation.

Contact complement 2 A 250 V AC 15 res. 3 A 24 V DC 13

Mechanical life S 2 6 million (operating cycles)
 Mechanical life SS 2 10 million (operating cycles)
 Permissible ambient temperature Operation -40° C to +60° C
 Storage -50° C to +80° C

Climate resistance
 Damp heat constant DIN IEC 68 part 2-3
 Damp heat cyclic DIN IEC 68 part 2-30
 Degree of protection front IP 54 IEC 529 DIN 40050
 Technical data see catalog 5/100
 Description data see catalog 5/002

Spindle block with schematic representation of the master controller installation and deflection directions. Version shown for left-hand side installation (right-hand side installation is mirror image).

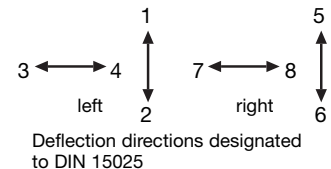

Pos.	S 2	Type expansion	Weight gramm	Type	Price EURO	
1			600	S 2		
2			650	SS 2		
3						
4						
5						
7.1	Single-axis controller left (dir. 1-2, 3-4)			L		
7.2	Single-axis controller right (dir. 5-6, 7-8)			R		
11	Gate special-shaped (for position view) M 1699		60	P		
20	Control-handle with knob solid					
21	Control-handle with latch for mechanical zero interlock					
21.1	by lifting		50	M		
21.3	by pushing down		50	MN		
21.4	Mechanical zero interlock with command devices see catalog 1/282					
22	Control-handle with dead man's button 1 NO		50	T		
23	Control-handle with signal button 1 NO		50	H		
24	Control-handle with push button 1 NO		60	D		
25	Control-handle with flat push button 1 NO		60	DV		
26	Control-handle with palm grip B 5		40	B 5		
27	Control-handle with palm grip B 5 with push button top 1 NO		60	B 5T		
28	Control-handle long or short					
28.1	-20 mm			S5		
28.2	+20 mm			S8		
29	More knobs, grips and T-grips with and without signal devices see catalog 1/280...					
30	Masterswitch (contact) switching sequenc 5-0-5		No. of contacts 3	02		
31			5	03		
32			7	04		
33	Switching program according contact-arrangement MS... see catalog 5/001	A...	9	05		
34	or to your contact-arrangement					
35						
37	Micro change over contact (MZT1) positive opening (additional price)		1			
38	Spring return in 0-position (for each direction)			Z		
39	Friction brake adjustable (for each direction)			R		
40	Potentiometer e.t.c. each masterswitch with mounted Wire-wound potentiometer T 130, with centre tap, 1,5 Watt wiper current max. 10 mA resistance 2 x 0,5k \triangleq P021, 2 x 1k \triangleq P022, 2 x 2k \triangleq P023, 2 x 5k \triangleq P024, 2 x 10k \triangleq P025	...P02 \square		70	P	
41	Prepared for mounting potentiometer shaft 6 mm adjusting-angle 2 x 150°				(P)	
42	Prepared for mounting potentiometer e.t.c. adjusting-angle variable.				(P)	
43	more Potentiometer e.t.c. see catalog 1/240...	C..., P...				
50	Steel sheet housing B 200 masterswitch Gr. 05			1300	B	
52	More housing see catalog 1/350					
60	Indicating labels not engraved with 2 arrows					
61	Engraving, each 10 characters					
70	Command and indicating devices see catalog 1/360					



T = dead man's button
H = signal button
M = latch for mechanical zero interlock

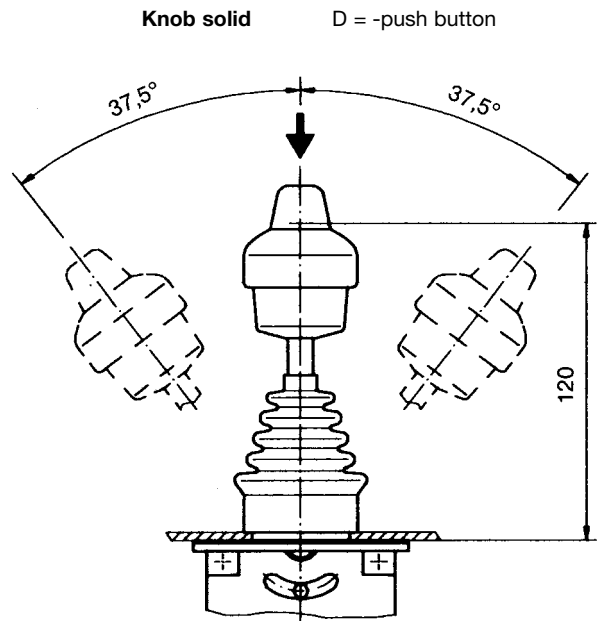
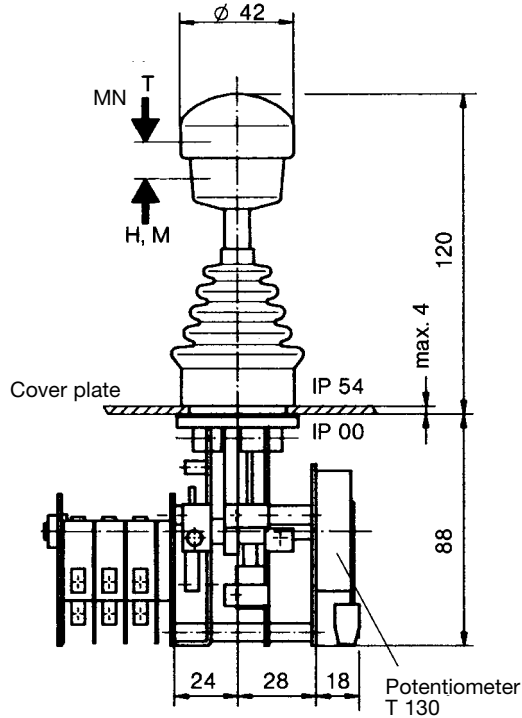

Type	No. of contacts	Dimension B
02	3	62
03	5	72
04	7	83
05	9	93

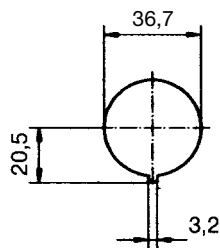
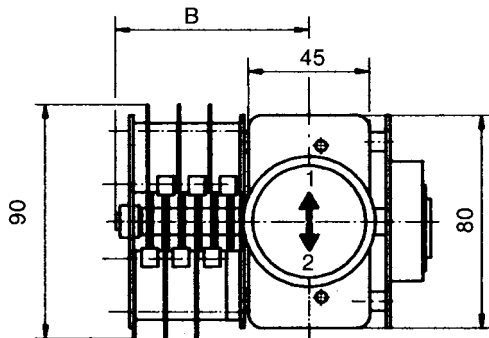

Hole pattern

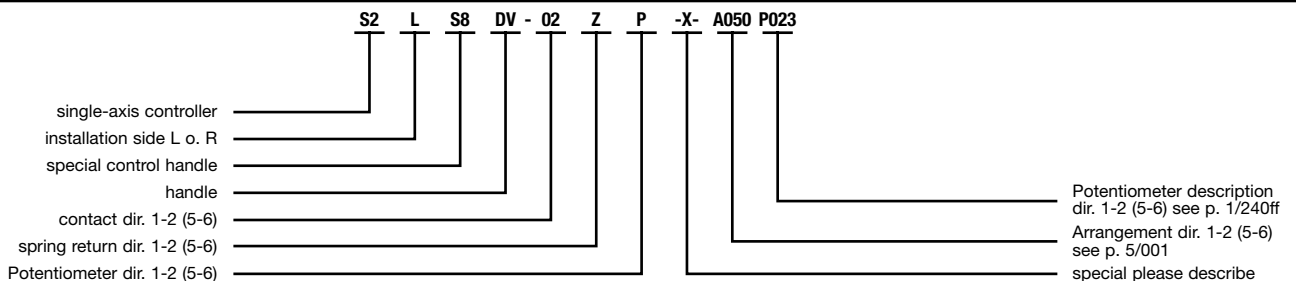
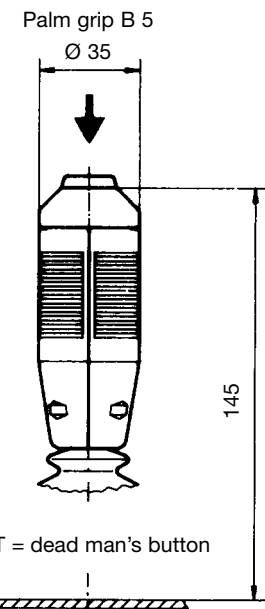

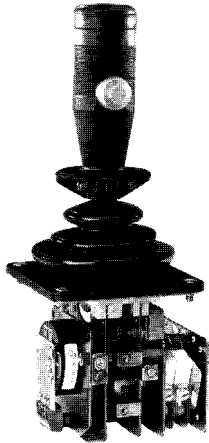

Type S21LB12D-02ZP-...

The single-axis controller S 21 is a rugged switching device according IEC 947-5-1 EN 60947 DIN VDE 0660-200 for electro-hydraulic applications. The modular design enables the switching device to be used universally. The S 21 is resistant to oil, maritime climate, ozone and UV radiation.

Contact complement 2 A 250 V AC 15 res. 3 A 24 V DC 13

Mechanical life S 21 6 million (operating cycles)
 Mechanical life SS 21 10 million (operating cycles)
 Permissible ambient temperature Operation -40° C to +60° C
 Storage -50° C to +80° C

Climate resistance
 Damp heat constant DIN IEC 68 part 2-3
 Damp heat cyclic DIN IEC 68 part 2-30
 Degree of protection front IP 54 IEC 529 DIN 40050
 Technical data see catalog 5/100
 Description data see catalog 5/002

Spindle block with schematic representation of the master controller installation and deflection directions. Version shown for left-hand side installation (right-hand side installation is mirror image).

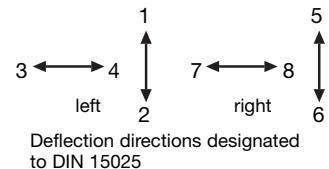

Pos.	S 21	Type expansion		Weight gramm	Type	Price EURO
1				650	S 21	
2				650	SS 21	
3						
4						
5						
7.1	Single-axis controller left (dir. 1-2, 3-4)				L	
7.2	Single-axis controller right (dir. 5-6, 7-8)				R	
20	Control-handle with knob solid					
21	Control-handle with latch for mechanical zero interlock					
21.1	by lifting			50	M	
21.3	by pushing down			50	MN	
21.4	Mechanical zero interlock with command devices see catalog 1/282					
22	Control-handle with dead man's button 1 NO			100	T	
23	Control-handle with signal button 1 NO			100	H	
24	Control-handle with push button 1 NO			110	D	
25	Control-handle with flat push button 1 NO			110	DV	
26	Control-handle with palm grip B 1			40	B 1	
27	Control-handle with palm grip B 1 with push button top 1 NO			60	B 1T	
28	Control-handle long or short					
28.1	-20 mm				S5	
28.2	+20 mm				S8	
29	More knobs, grips and T-grips with and without signal devices see catalog 1/280...					
30	Masterswitch (contact) switching sequenc 5-0-5		No. of contacts 3	300	02	
31			5	330	03	
32			7	360	04	
33	Switching program according contact-arrangement MS... see catalog 5/001		9	390	05	
34	or to your contact-arrangement	A...				
35						
36						
38	Spring return in 0-position (for each direction)			20	Z	
39	Friction brake adjustable (for each direction)			20	R	
40	Potentiometer e.t.c. each masterswitch with mounted Wire-wound potentiometer T 130, with centre tap, 1,5 Watt wiper current max. 10 mA resistance 2 x 0,5k \triangle P021, 2 x 1k \triangle P022, 2 x 2k \triangle P023, 2 x 5k \triangle P024, 2 x 10k \triangle P025	...P02 \square		70	P	
41	Prepared for mounting potentiometer shaft 6 mm adjusting-angle 2 x 150°				(P)	
42	Prepared for mounting potentiometer e.t.c. adjusting-angle variable.				(P)	
43	more Potentiometer e.t.c. see catalog 1/240...	C..., P...				
50	Steel sheet housing B 200 masterswitch Gr. 05			1300	B	
51						
52	More housing see catalog 1/350					
60	Indicating labels not engraved with 2 arrows					
61	Engraving, each 10 characters					
70	Command and indicating devices see catalog 1/360					



T = dead man's button
H = signal button
M = latch for mechanical zero interlock

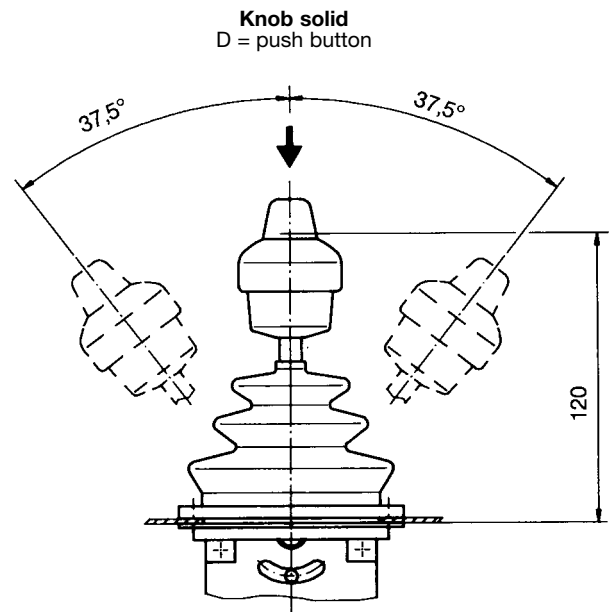
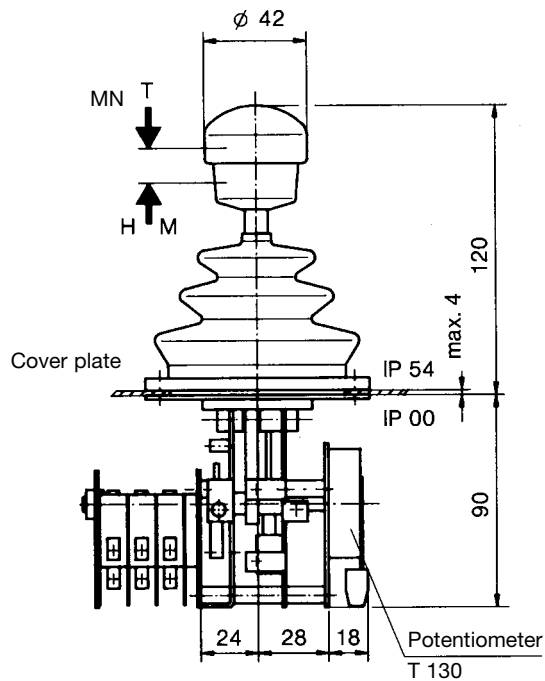

Palm grip B 1

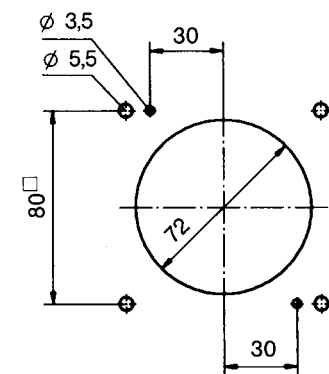
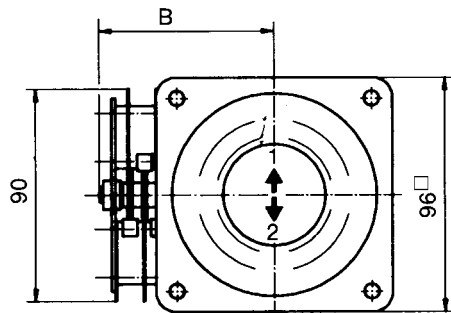
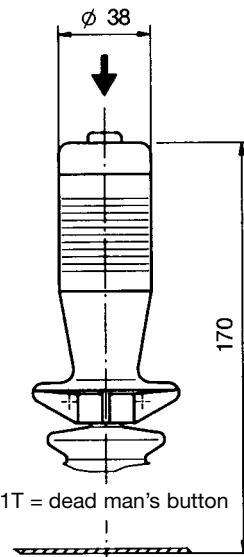

Hole pattern

Type	No. of contacts	Dimension B
02	3	62
03	5	72
04	7	83
05	9	93

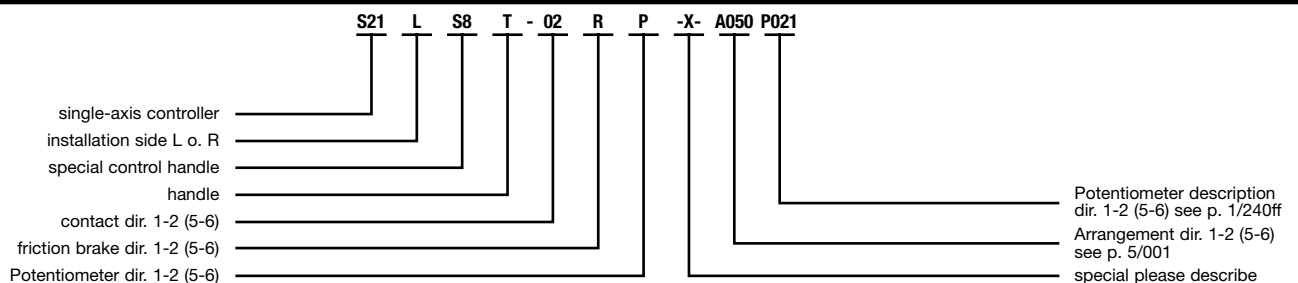

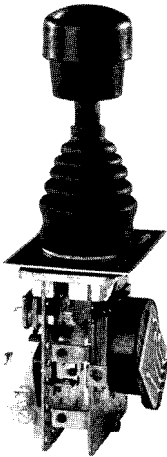

Type S22LT-2ZP-...

The single-axis controller S 22 is a rugged switching device according IEC 947-5-1 EN 60947 DIN VDE 0660-200 for electro-hydraulic applications. The modular design enables the switching device to be used universally. The S 21 is resistant to oil, maritime climate, ozone and UV radiation.

Contact complement 2 A 250 V AC 15 res. 3 A 24 V DC 13

Mechanical life S 22 6 million (operating cycles)
 Mechanical life SS 22 10 million (operating cycles)
 Permissible ambient temperature Operation -40° C to +60° C
 Storage -50° C to +80° C

Climate resistance
 Damp heat constant DIN IEC 68 part 2-3
 Damp heat cyclic DIN IEC 68 part 2-30
 Degree of protection front IP 54 IEC 529 DIN 40050
 Technical data see catalog 5/100
 Description data see catalog 5/002

Spindle block with schematic representation of the master controller installation and deflection directions.
 Version shown for left-hand side installation (right-hand side installation is mirror image).

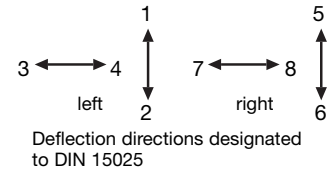

Pos.	S 22	Type expansion		Weight gramm	Type	Price EURO
1				600	S 22	
2				650	SS 22	
3						
4						
5						
7.1	Single-axis controller left (dir. 1-2, 3-4)				L	
7.2	Single-axis controller right (dir. 5-6, 7-8)				R	
20	Control-handle with knob solid					
21	Control-handle with latch for mechanical zero interlock					
21.1	by lifting			50	M	
21.3	by pushing down			50	MN	
21.4	Mechanical zero interlock with command devices see catalog 1/282					
22	Control-handle with dead man's button 1 NO			50	T	
23	Control-handle with signal button 1 NO			50	H	
24	Control-handle with push button 1 NO			60	D	
25	Control-handle with flat push button 1 NO			60	DV	
26	Control-handle with palm grip B 1			40	B 5	
27	Control-handle with palm grip B 1 with push button top 1 NO			60	B 5T	
28	Control-handle long or short					
28.1	-20 mm				S5	
28.2	+20 mm				S8	
29	More knobs, grips and T-grips with and without signal devices see catalog 1/280...					
30	Masterswitch (contact) switching sequenc -0-		No. of contacts 1	150	1	
31			2	170	2	
32			3	190	3	
33	Switching program according contact-arrangement MS... see catalog 5/001	A...	4	210	4	
34	or to your contact-arrangement					
35						
36	Switching sequence 2-0-2					
38	Spring return in 0-position (for each direction)			20	Z	
39	Friction brake adjustable (for each direction)			20	R	
40	Potentiometer e.t.c. each masterswitch with mounted Wire-wound potentiometer T 130, with centre tap, 1,5 Watt wiper current max. 10 mA resistance 2 x 0,5k \triangle P021, 2 x 1k \triangle P022, 2 x 2k \triangle P023, 2 x 5k \triangle P024, 2 x 10k \triangle P025	...P02 \square		70	P	
41	Prepared for mounting potentiometer shaft 6 mm adjusting-angle 2 x 150°				(P)	
42	Prepared for mounting potentiometer e.t.c. adjusting-angle variable.				(P)	
43	more Potentiometer e.t.c. see catalog 1/240...	C..., P...				
50	Steel sheet housing B 200 masterswitch Gr. 4			1300	B	
51						
52	More housing see catalog 1/350					
60	Indicating labels not engraved with 2 arrows					
61	Engraving, each 10 characters					
70	Command and indicating devices see catalog 1/360					



T = dead man's button
H = signal button
M = latch for mechanical zero interlock

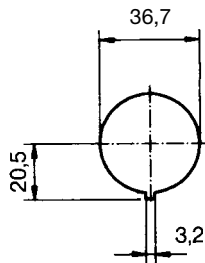
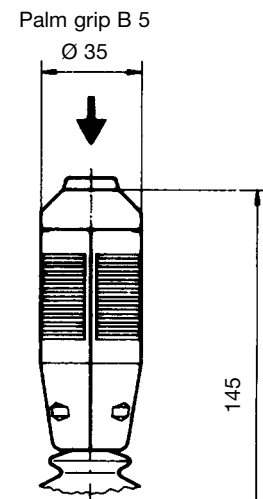
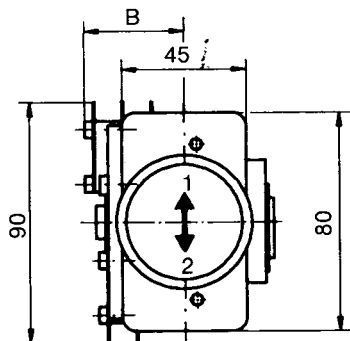
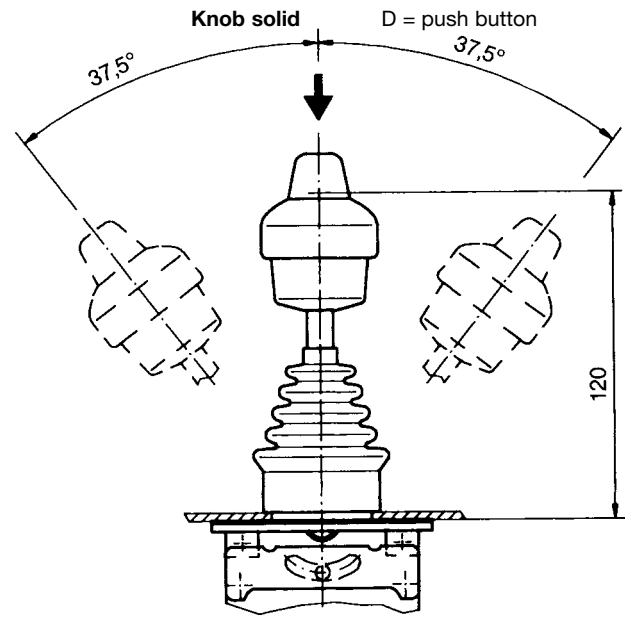
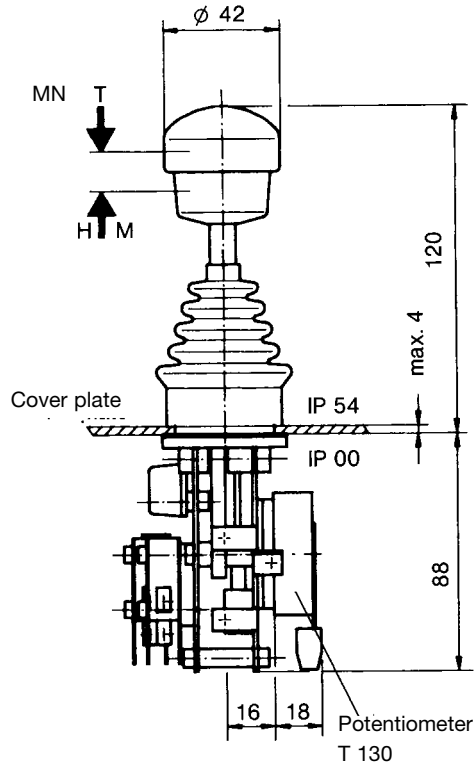

B 5T = dead man's button

Type	No. of contacts	Dimension B
1	1	25
2	2	31
3	3	36
4	4	42

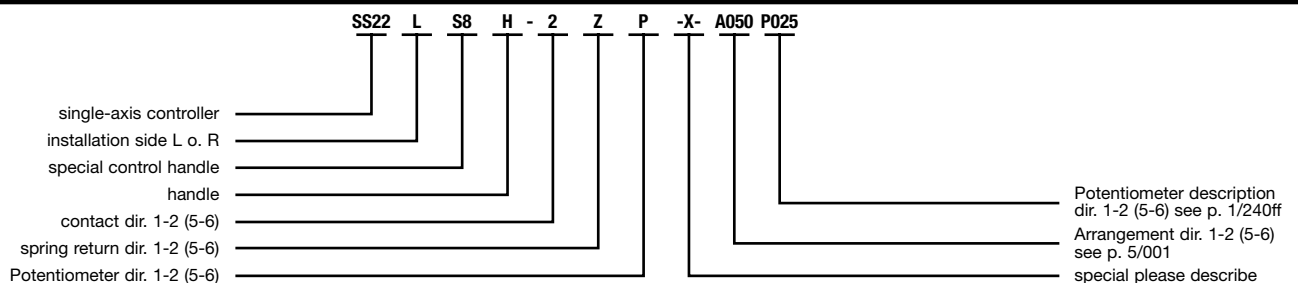

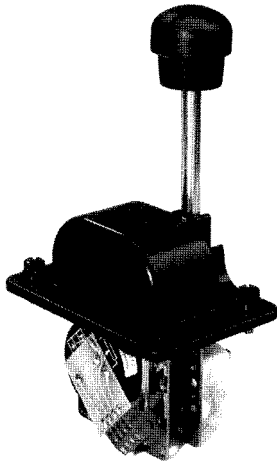

Type S23L-2ZP-...

The single-axis controller S 23 is a rugged switching device according IEC 947-5-1 EN 60947 DIN VDE 0660-200 for electro-hydraulic applications and offshore. The modular design enables the switching device to be used universally. The S 23 is resistant to oil, maritime climate, ozone and UV radiation.

Contact complement 2 A 250 V AC 15 res. 3 A 24 V DC 13

Mechanical life 6 million (operating cycles)
Permissible ambient temperature Operation -40° C to +60° C
Storage -50° C to +80° C

Climate resistance
Damp heat constant DIN IEC 68 part 2-3
Damp heat cyclic DIN IEC 68 part 2-30
Degree of protection front IP 65 IEC 529 DIN 40050
Technical data see catalog 5/100
Description data see catalog 5/002

Spindle block with schematic representation of the master controller installation and deflection directions. Version shown for left-hand side installation (right-hand side installation is mirror image).

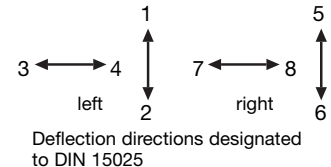

Pos.	S 23	Type expansion	Weight gramm	Type	Price EURO
1			700	S 23	
2					
3					
4					
5					
7.1	Single-axis controller left (dir. 1-2, 3-4)			L	
7.2	Single-axis controller right (dir. 5-6, 7-8)			R	
10					
20	Control-handle with knob solid				
21	Control-handle with latch for mechanical zero interlock by lifting		50	M	
21.1					
22					
23					
24					
25					
26	Control-handle with T-grip		40	Q	
27					
28	Control-handle long or short				
28.1	-20 mm			S5	
28.2	+20 mm			S8	
29					
30	Masterswitch (contact) switching sequenc -0-		No. of contacts 1	1	
31			2	2	
32			3	3	
33	Switching program according contact-arrangement MS... see catalog 5/001	A...	4	4	
34	or to your contact-arrangement				
35					
36	Switching sequence 2-0-2				
38	Spring return in 0-position (for each direction)		20	Z	
39	Friction brake adjustable (for each direction)		20	R	
40	Potentiometer e.t.c. each masterswitch with mounted Wire-wound potentiometer T 130, with centre tap, 1,5 Watt wiper current max. 10 mA resistance 2 x 0,5k \pm P021, 2 x 1k \pm P022, 2 x 2k \pm P023, 2 x 5k \pm P024, 2 x 10k \pm P025	...P02 \square	70	P	
41	Prepared for mounting potentiometer shaft 6 mm adjusting-angle 2 x 150°			(P)	
42	Prepared for mounting potentiometer e.t.c. adjusting-angle variable.			(P)	
43	more Potentiometer e.t.c. see catalog 1/240...	P...			
50	Steel sheet housing B 200 masterswitch Gr. 4		1300	B	
51					
52	More housing see catalog 1/350				
60	Indicating labels not engraved with 2 arrows				
61	Engraving, each 10 characters				
62					
70	Command and indicating devices see catalog 1/360				

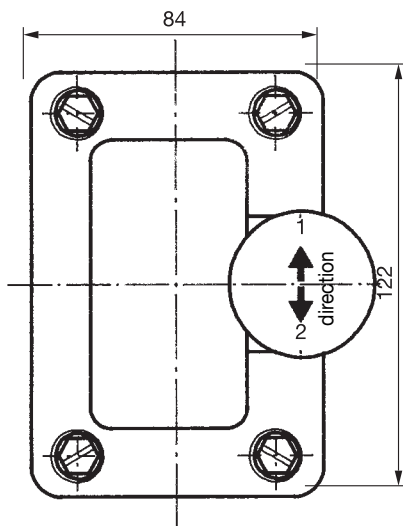
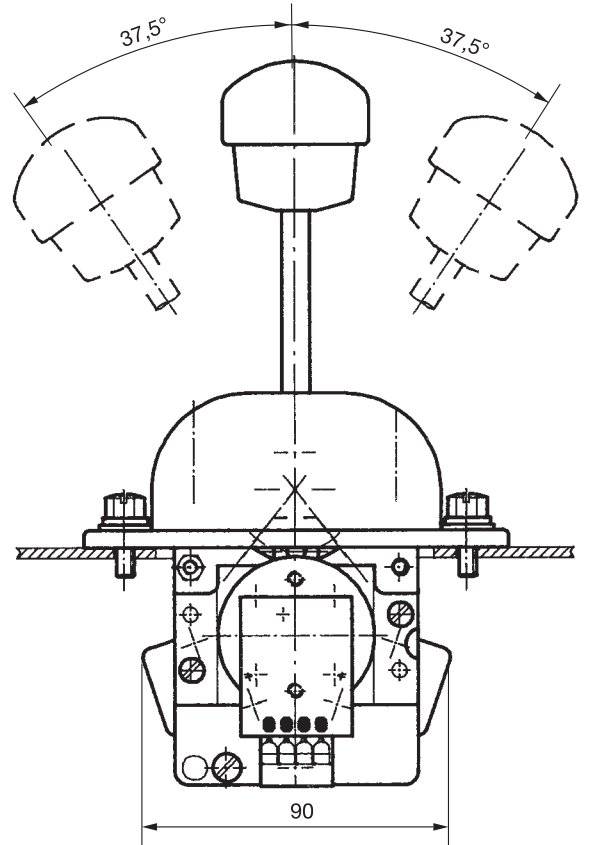
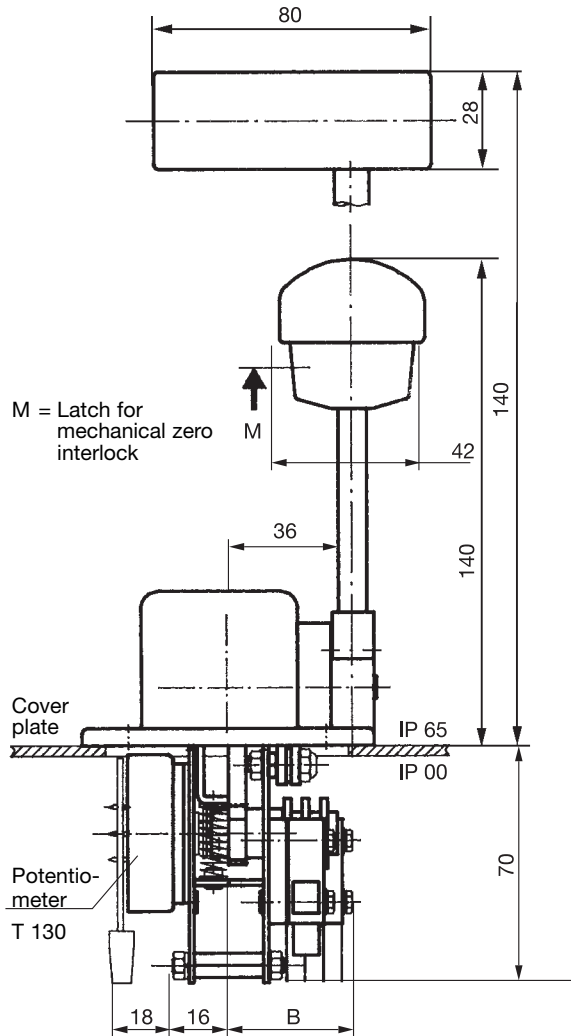

Type	No. of contacts	Dimension B
1	1	25
2	2	31
3	3	36
4	4	42

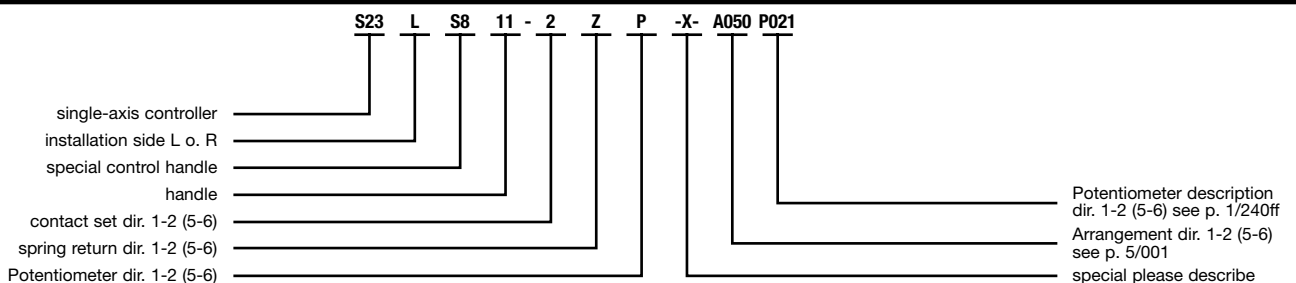
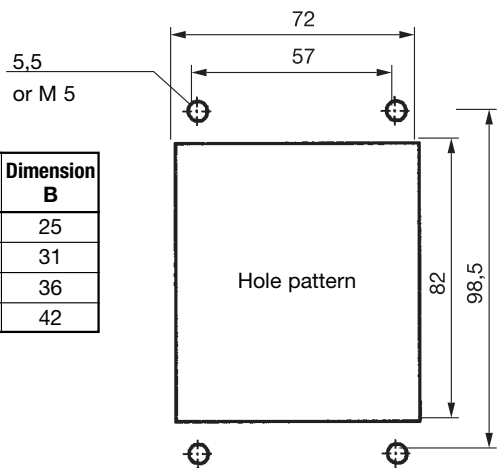



Type S3LQ-2ZP-B...

The single-axis controller S 3 is a rugged switching device according IEC 947-5-1 EN 60947 DIN VDE 0660-200 for nautical navigation applications. The modular design enables the switching device to be used universally. The S 3 is resistant to oil, maritime climate, ozone and UV radiation.

Contact complement 0,5 A 110 V AC 15 res. 1,5 A 24 V DC 13
I min > 0,2 mA 2 V DC 12 Gold plated for max. load of 0,12 Watt (standard)

Mechanical life 12 million (operating cycles)
Permissible ambient temperature Operation -40° C to +60° C
Storage -50° C to +80° C

Climate resistance
Damp heat constant DIN IEC 68 part 2-3
Damp heat cyclic DIN IEC 68 part 2-30
Degree of protection front IP 66 IEC 529 DIN 40050
Technical data see catalog 5/100
Description data see catalog 5/002

Spindle block with schematic representation of the master controller installation and deflection directions.
Version shown for left-hand side installation (right-hand side installation is mirror image).

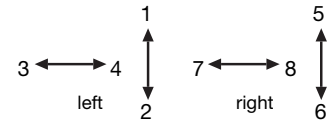

Deflection directions designated to DIN 15025

Pos.	S 3	Type expansion		Weight gramm	Type	Price EURO
1				2700	S 3	
2						
3						
4						
5						
7.1	Single-axis controller left (dir. 1-2, 3-4)				L	
7.2	Single-axis controller right (dir. 5-6, 7-8)				R	
10						
20	Control-handle with knob solid					
21						
22						
23						
24	Control-handle with push button 1 NO			110	D	
25						
26	Control-handle with T-grip			40	Q	
27	Control-handle with T-grip and push button side 1 NO			60	QD	
28	Control-handle long or short					
28.1	-20 mm				S5	
28.2	+20 mm				S8	
30	Masterswitch (contact) switching sequenc -0-		No. of contacts 1	20	1	
31			2	40	2	
32	Direction 1-2 or 3-4		3	60	3	
33	Switching program according contact-arrangement MS... see catalog 5/001	A...				
34	or to your contact-arrangement					
35						
36	Switching sequence special					
38	Spring return in 0-position (for each direction)			30	Z	
39	Friction brake adjustable (for each direction)			30	R	
40	Potentiometer e.t.c. each masterswitch with mounted Conductive-plastic potentiometer T 246, with centre tap linear Life 10 ⁷ switching cycles resistance 2 x 5 kOhm, 0,5 Watt wiper current max. 1 mA	...P214		70	P	
41	Prepared for mounting potentiometer shaft 6 mm adjusting-angle 2 x 75°				(P)	
42	Prepared for mounting potentiometer e.t.c. adjusting-angle variable.				(P)	
43	more Potentiometer e.t.c. see catalog 1/240...	P...				
50	Cover housing			300	B	
51	Filter plug M 20 for air-condition			20		
52	Cable entry M 32 with anti-kink protection			30		
60	Indicating label eloxal aluminium plate silvery (included in the spindle block)					
61	Engraving, each 10 characters					

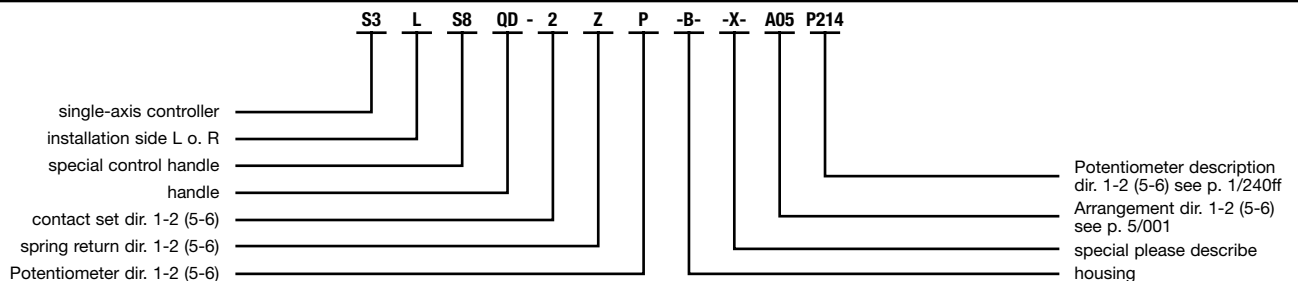
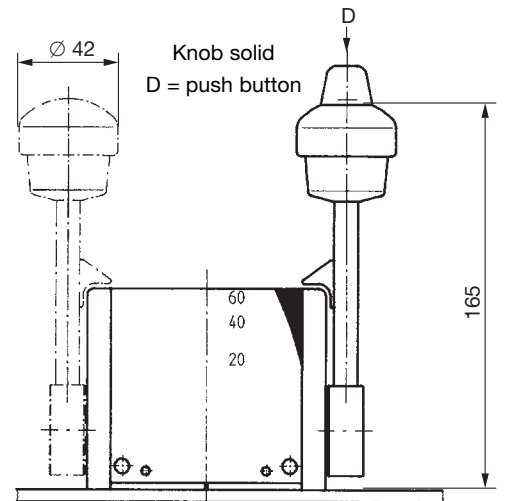
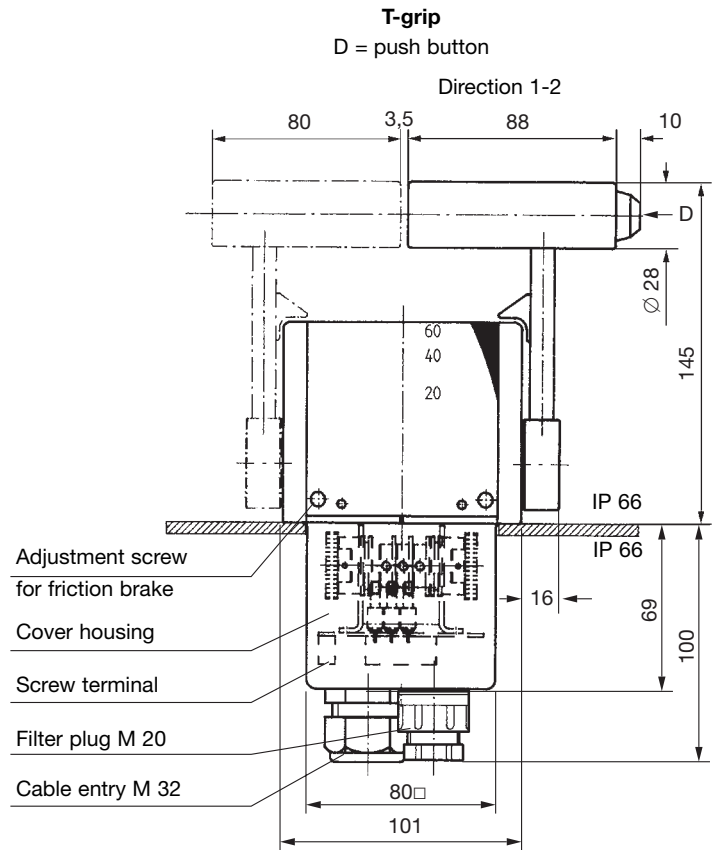
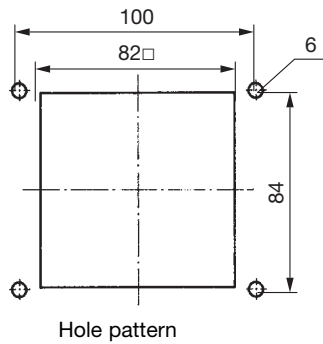
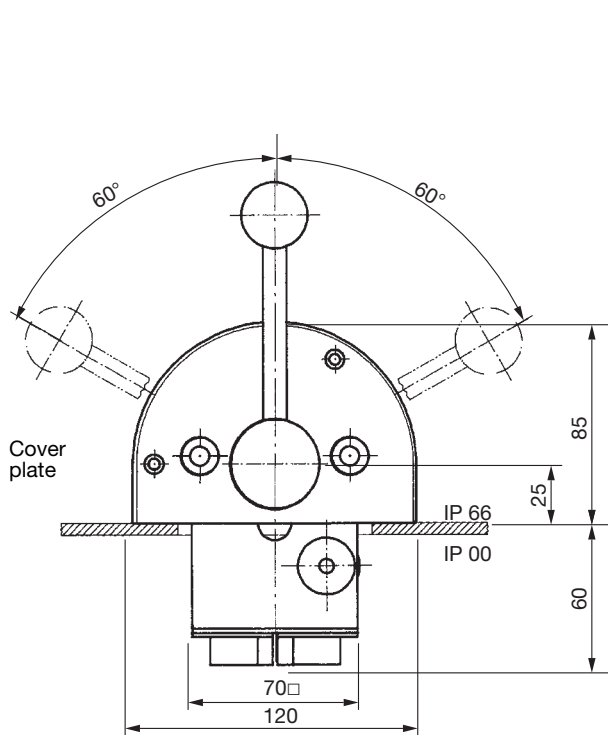

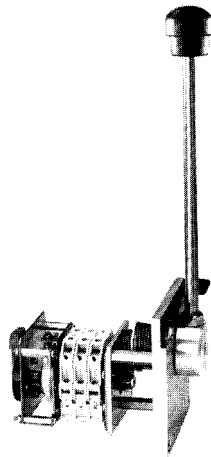

Type S6L-03ZP-...

The single-axis controller S 6 is a rugged switching device according IEC 947-5-1 EN 60947 DIN VDE 0660-200 for hoisting applications. The modular design enables the switching device to be used universally. The S 6 is resistant to oil, maritime climate, ozone and UV radiation.

Contact complement 2 A 250 V AC 15 res. 1 A 24 V DC 13 (standard) or 4 A 250 V AC 15 (special)

Mechanical life 10 million (operating cycles)
Permissible ambient temperature Operation -40° C to +60° C
Storage -50° C to +80° C

Climate resistance
Damp heat constant DIN IEC 68 part 2-3
Damp heat cyclic DIN IEC 68 part 2-30
Degree of protection front IP 54 IEC 529 DIN 40050

Technical data see catalog 5/100
Description data see catalog 5/002

Spindle block with schematic representation of the master controller installation and deflection directions.

Version shown for left-hand side installation (right-hand side installation is mirror image).

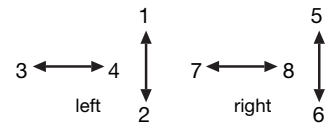

Deflection directions designated to DIN 15025

Pos.	S 6	Type expansion		Weight gramm	Type	Price EURO
1				960	S 6	
2						
3						
4						
5						
7.1	Single-axis controller left (dir. 1-2, 3-4)				L	
7.2	Single-axis controller right (dir. 5-6, 7-8)				R	
10						
20						
21						
22						
23						
24	Control-handle with push button 1 NO with flexible cable			110	D	
25						
26	Control-handle with palm grip B 1			40	B 1	
27	Control-handle with palm grip B 1 with push button top 1 NO			60	B 1D	
28	Control-handle long or short					
28.1	-20 mm				S5	
28.2	+20 mm				S8	
30	Masterswitch (contact set) switching sequenc 4-0-4		No. of contacts 2	290	01	
31			4	350	02	
32	Direction 1-2 or 3-4		6	410	03	
33	Switching program according contact-arrangement MS... see catalog 5/001	A...	8	470	04	
34	or to your contact-arrangement		10	530	05	
35			12	590	06	
36	Switching sequence 5-0-5 or 6-0-6					
38	Spring return in 0-position (for each direction)			110	Z	
39	Friction brake adjustable (for each direction)			30	R	
40	Potentiometer e.t.c. each masterswitch with mounted Wire-wound potentiometer T 130, with centre tap, 1,5 Watt wiper current max. 10 mA resistance 2 x 0,5k \cong P021, 2 x 1k \cong P022, 2 x 2k \cong P023, 2 x 5k \cong P024, 2 x 10k \cong P025	...P02 \square		70	P	
41	Prepared for mounting potentiometer shaft 6 mm adjusting-angle 2 x 150°				(P)	
42	Prepared for mounting potentiometer e.t.c. adjusting-angle variable.				(P)	
43	more Potentiometer e.t.c. see catalog 1/240...	C..., P...			(P)	
50						
51						
52	More housing see catalog 1/350					
60	Indicating labels not engraved with 2 arrows					
61	Engraving, each 10 characters					
70	Command and indicating devices see catalog 1/360					

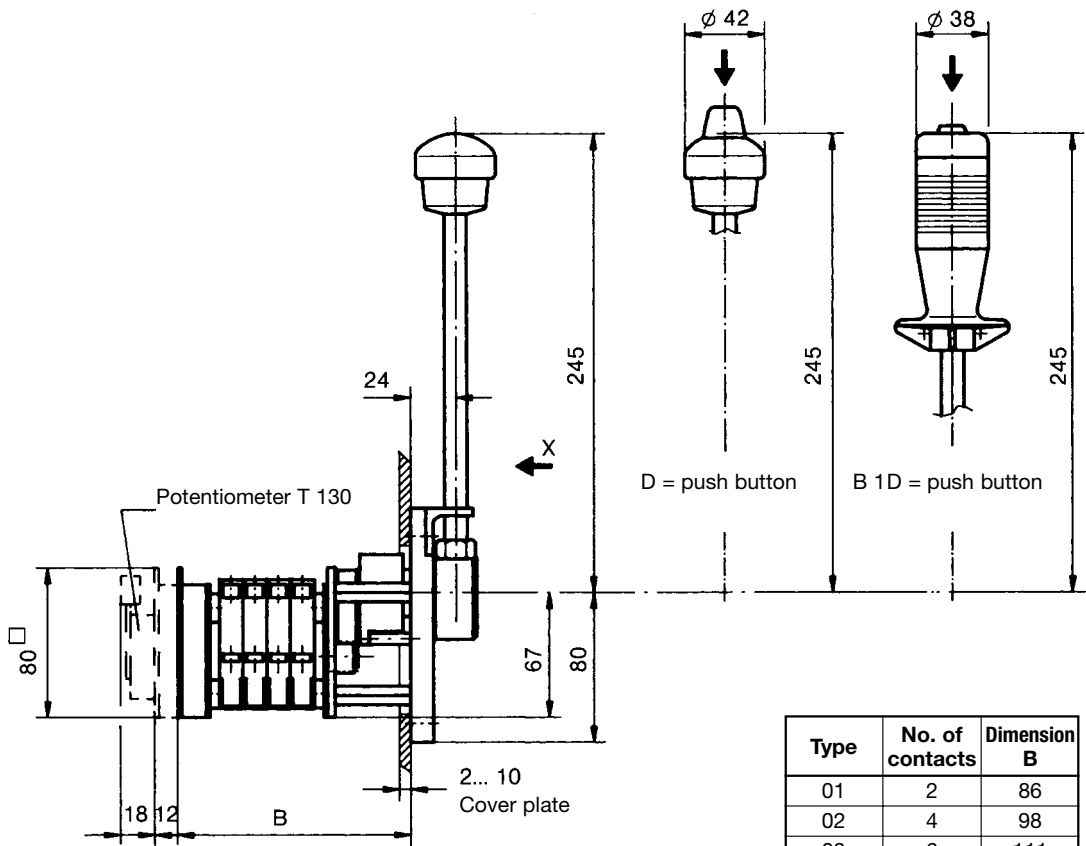

Type	No. of contacts	Dimension B
01	2	86
02	4	98
03	6	111
04	8	123
05	10	136
06	12	148

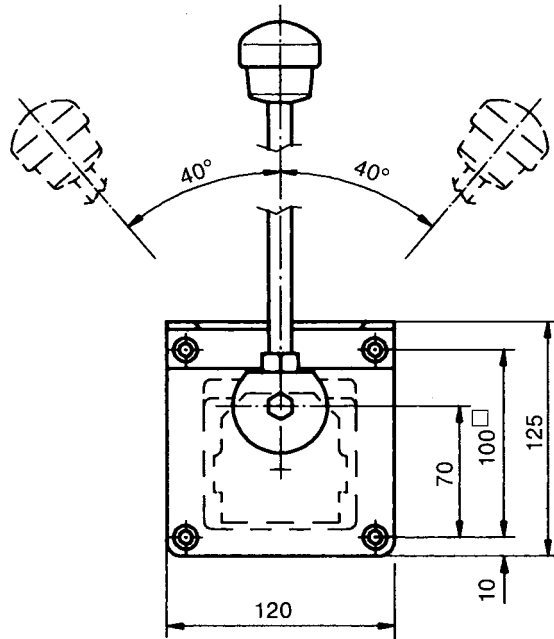

View X

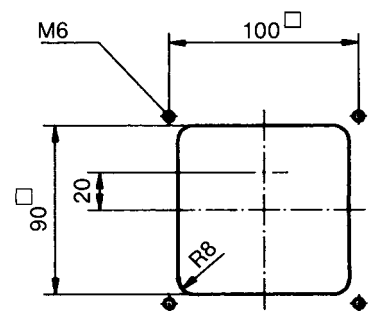

Hole pattern

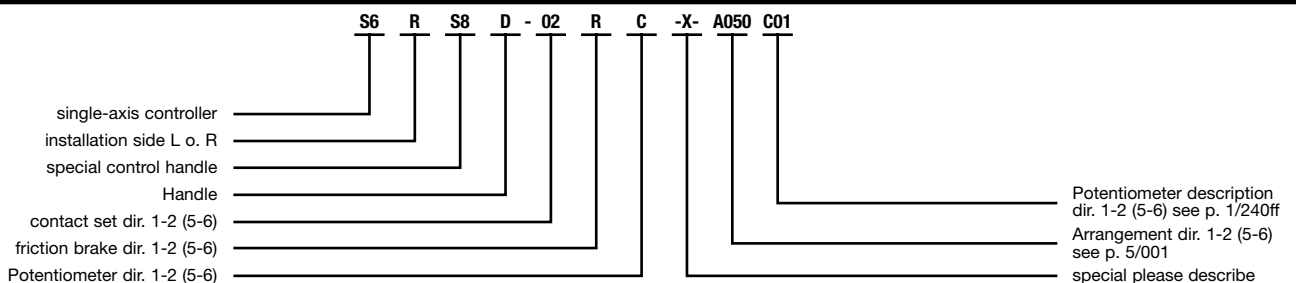

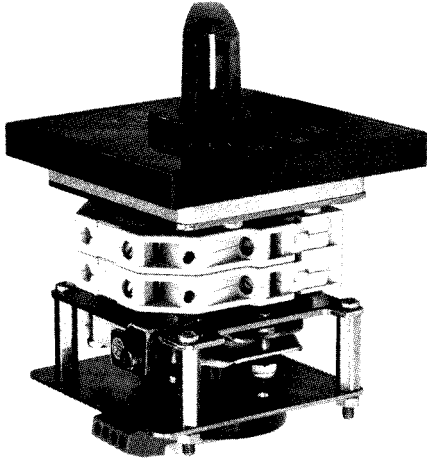

Form N6-KN-02RP...

The control-switch N 6 is a rugged switching device according IEC 947-5-1 EN 60947 DIN VDE 0660-200 for hoisting and electro-hydraulic applications.

The modular design enables the switching device to be used universally. The N 6 is resistant to oil, maritime climate, ozone and UV radiation.

Contact complement 2 A 250 V AC 15 res. 1 A 24 V DC 13 (standard) or 4 A 250 V AC 15 (special)

Mechanical life 10 million (operating cycles)
Permissible ambient temperature Operation -40° C to +60° C
Storage -50° C to +80° C

Climate resistance
Damp heat constant DIN IEC 68 part 2-3
Damp heat cyclic DIN IEC 68 part 2-30
Degree of protection front IP 54 IEC 529 DIN 40050

Technical data see catalog 5/100
Description data see catalog 5/002

Pos.		Type expansion		Weight gramm	Type	Price EURO
1	Drive with free shaft end with front plate 88x88 mm				N6	
2	Knob			30	KN	
3	Ball-handle			50	HG	
4	Rotary mechanism			30	DG	
5						
6	Degree of protection, front IP 65 by seal ring					
30	Control-switch insert (contact set)		No. of contacts 2	290	01	
31	with free shaft end		4	350	02	
32	Switching sequence 4-0-4		6	410	03	
33	Switching program according contact-arrangement MS see catalog 5/001	A...	8	470	04	
34	or to your contact-arrangement		10	530	05	
35			12	590	06	
36	Switching sequence 5-0-5 or 6-0-6 or 0-18					
37	Micro changeover contact (MZT1) positive opening (additional price)		2			
38	Spring return in 0-position max. 100 Grad (2 x 70°)			110	Z	
39	Friction brake adjustable max. 260 Grad (2 x 130°)			30	R	
40	Potentiometer e.t.c. with mounted Wire-wound potentiometer T 130 with centre tap linear 1,5 Watt wiper current max. 10 mA resistance 2 x 0,5k \triangleq P021, 2 x 1k \triangleq P022, 2 x 2k \triangleq P023, 2 x 5k \triangleq P024, 2 x 10k \triangleq P025	...P02 \square		70	P	
41	Prepared for mounting potentiometer shaft 6 mm adjusting-angle 2 x 150°				(P)	
42	Prepared for mounting potentiometer e.t.c. adjusting-angle variable.				(P)	
43	more Potentiometer e.t.c. see catalog 1/240...	C..., P...				
52	Housing see catalog 1/350					
60	Indicating labels not engraved					
61	Engraving, each 10 characters					
70	Command and indicating devices see catalog 1/360					

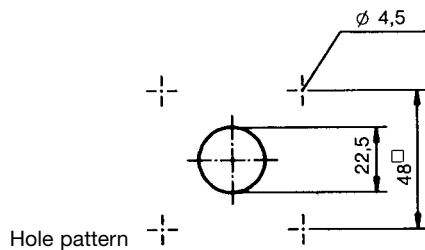
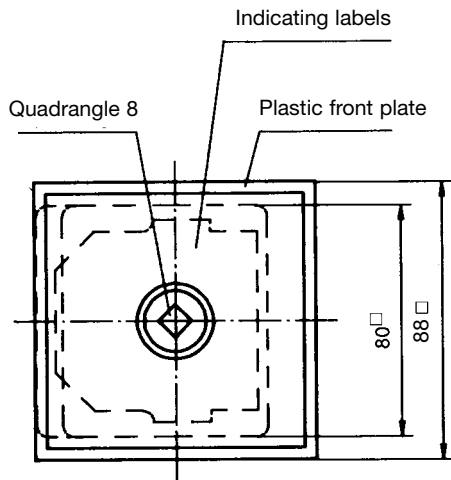
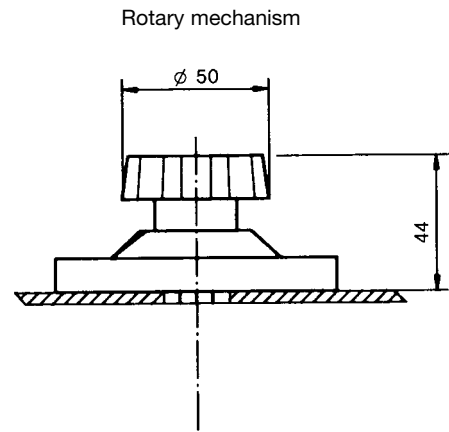
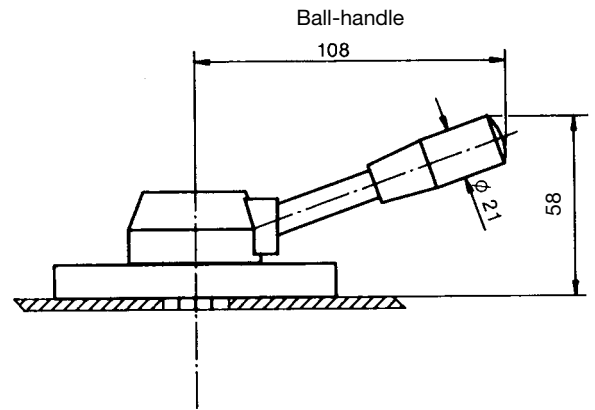
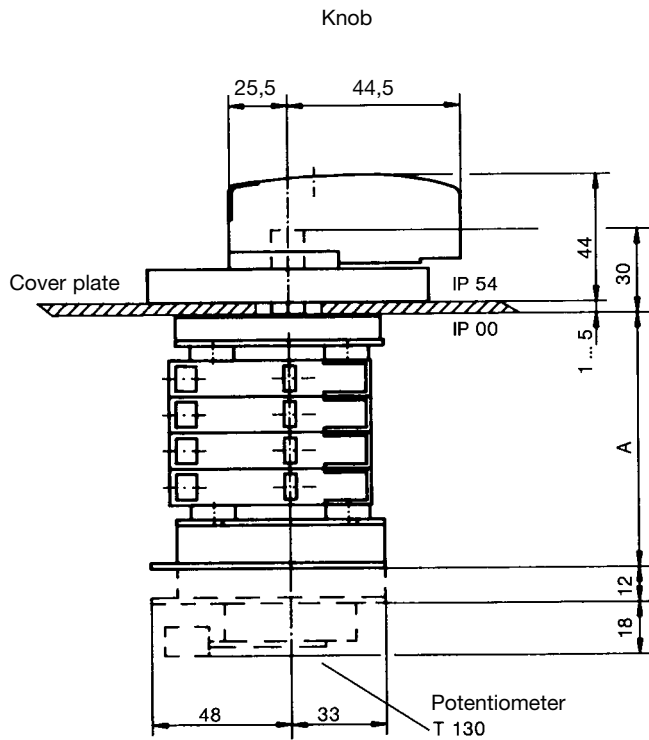

Type	No. of contacts	Dimension A	Spring return
01	2	51	+25
02	4	63	
03	6	76	
04	8	88	
05	10	101	
06	12	113	

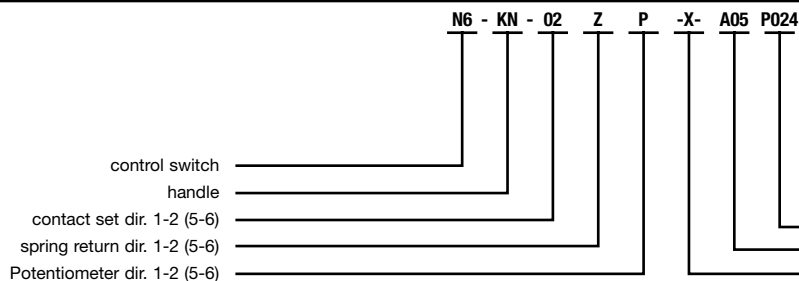

Potentiometer description dir. 1-2 (5-6) see p. 1/240ff
Arrangement dir. 1-2 (5-6) see p. 5/001
special please describe



□ = resistance value linear and part number \triangle $\left\{ \begin{array}{ll} 1 = 0.5 \text{ kOhm, with centre tap} & 2 \times 0.5 \text{ kOhm} \\ 2 = 1.0 \text{ kOhm, with centre tap} & 2 \times 1.0 \text{ kOhm} \\ 3 = 2.0 \text{ kOhm, with centre tap} & 2 \times 2.0 \text{ kOhm} \\ 4 = 5.0 \text{ kOhm, with centre tap} & 2 \times 5.0 \text{ kOhm} \\ 5 = 10.0 \text{ kOhm, with centre tap} & 2 \times 10.0 \text{ kOhm} \end{array} \right.$

Pos.	for mounting on: V 6 / D 64 / V 5 / V 3 / S 2 / S 6 / N 6 / P 7 / P 8	Type	Weight gramm	Part No. 5240...	Type	Price EURO
1	Wire-wound potentiometer linear life 10 ⁷ switching cycles 1,5 Watt max. wiper current 10 mA	T 129	60	...00100 □	P01 □	
2	Wire-wound potentiometer linear with centre tap life 10 ⁷ switching cycles 1,5 Watt max. wiper current 10 mA	T 130	60	...00200 □	P02 □	
3	Wire-wound potentiometer linear life 10 ⁷ switching cycles 2,5 Watt max. wiper current 10 mA	T 131	70	...00300 k	P03 □	
4	like T 131 but with oil-filling protection for corrossion	T 131-Oel	80	...00400 □	P04 □	
5	Wire-wound potentiometer linear with centre tap life 10 ⁷ switching cycles 2,5 Watt max. wiper current 10 mA	T 132	70	...00500 □	P05 □	
6	like T 132 but with oil-filling protection for corrossion	T 132-Oel	80	...00600 □	P06 □	
7	Wire-wound potentiometer characteristic progressive with centre tap life 10 ⁷ switching cycles 1,5 Watt max. wiper current 10 mA	T 178	70	...00700 □	P07 □	
8	Wire-wound potentiometer linear with centre tap life 5 x 10 ⁸ switching cycles 1Watt max. wiper current 10 mA	T 238	20	...00800 □	P08 □	
9	Wire-wound potentiometer linear life 5 x 10 ⁸ switching cycles 1 Watt max. wiper current 10 mA	T 237	20	...00900 □	P09 □	
10	Wire-wound potentiometer linear with centre tap life 10 ⁸ switching cycles 60 Watt	T 133	150	...01000 □	P10 □	
11	Wire-wound potentiometer linear life 10 ⁸ switching cycles 60 Watt	T 134	150	...01100 □	P11 □	
12	Conductive-plastic potentiometer linear life 10 ⁷ switching cycles 0,5 Watt max. wiper current 1 mA	T 374	20	...01200 □	P12 □	
13	Conductive-plastic potentiometer linear with centre tap life 10 ⁷ switching cycles 0,5 Watt max. wiper current 1 mA	T 396	20	...01300 □	P13 □	
14						
15						
16						
	for mounting on: V 8 / D 8 / P 10 / P 12					
17	Wire-wound potentiometer linear with centre tap life 5 x 10 ⁸ switching cycles 1 Watt max. wiper current 10 mA	T 239	20	...01700 □	P17 □	
18	Conductive-plastic potentiometer linear with centre tap life 10 ⁷ switching cycles 0,5 Watt max. wiper current 1 mA	T 301	20	...01800 □	P18 □	
19	Conductive-plastic potentiometer linear with centre tap life 10 ⁷ switching cycles; 3 conductive-plastic contact way arrangement MSP 21-0 (catalog 5/001) 0,5 Watt max.wiper current 1 mA	T 426	25	...01900 □	P19 □	
20	Conductive-plastic potentiometer double linear with centre tap life 10 ⁷ switching cycles; 0,5 Watt max. wiper current 1 mA	T 432	25	...02000 □	P20 □	
21	Conductive-plastic potentiometer with centre tap life 10 ⁷ switching cycles	T 246	20	...02100 □	P21 □	
22	Conductive-plastic potentiometer with centre tap life 10 ⁷ switching cycles	T 362	20	...02200 □	P22 □	
23						
	for mounting on: V 10					
24	Wire-wound potentiometer linear with centre tap life 5 x 10 ⁸ switching cycles 1 Watt max. wiper current 10 mA	T 321	20	...02400 □	P24 □	
25	Conductive-plastic potentiometer linear with centre tap life 10 ⁷ switching cycles 0,5 Watt max. wiper current 1 mA	T 320	20	...02500 □	P25 □	
26	Conductive-plastic potentiometer linear life 10 ⁷ switching cycles 0,5 Watt max. wiper current 1 mA	T 337	20	...02600 □	P26 □	
27	Conductive-plastic potentiometer linear with centre tap life 10 ⁷ switching cycles; 2 conductive-plastic contact way arrangement MSP 21 (catalog 5/001) 0,5 Watt max. wiper current 1 mA	T 430	25	...02700 □	P27 □	
28						
29						
30						
	for mounting on: V 11					
31	Wire-wound potentiometer linear with centre tap life 5 x 10 ⁸ switching cycles 1 Watt max. wiper current 10 mA	T 316	20	...03100 □	P31 □	
32	Conductive-plastic potentiometer linear with centre tap life 10 ⁷ switching cycles 0,5 Watt max. wiper current 1 mA	T 365	20	...03200 □	P32 □	
40	Special potentiometer				P99 □	
41	Prepared for mounting potentiometer adjusting-angle switching device \triangle potentiometer			...04100		
42	Prepared for mounting potentiometer adjusting-angle variable			...04200		



Pos.	for mounting on: V 6 / D 64 / V 11 / S 2 / S 6 / N 6		Type-expansion	Weight gramm	Type	Price EURO
10	Opto-electronic encoder	8 Bit Gray-Code T 359	OEC 2-1-1	410	C01	
11		8 Bit Binary-Code T 359	OEC 2-2-1	410	C02	
12		6 Bit Gray-Code T 359	OEC 2-3-□	410	C03□	
13		6 Bit Binary-Code T 359	OEC 2-4-□	410	C04□	
14		9 Bit Gray-Code T 384	OEC 2-5-□	410	C05□	
15		9 Bit Binary-Code T 384	OEC 2-6-□	410	C06□	
16						
17						
18						
19						

- = Output characteristic
- 1 = Linear
- 2 = Quadratic
- 3 = Progressive
- 4 = Linear one sided right turn
- 5 = Linear one sided left turn

Technical data
 Power supply 18-30 V DC
 Output PNP 24 V DC 10 mA
 Scanning Gray-Code
 Rotation angle max. ± 150° (360°)

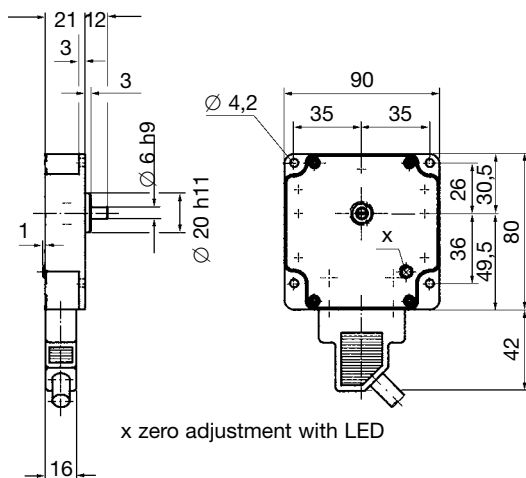
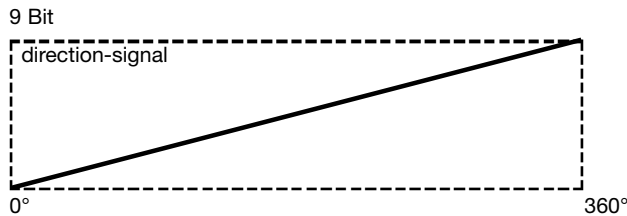
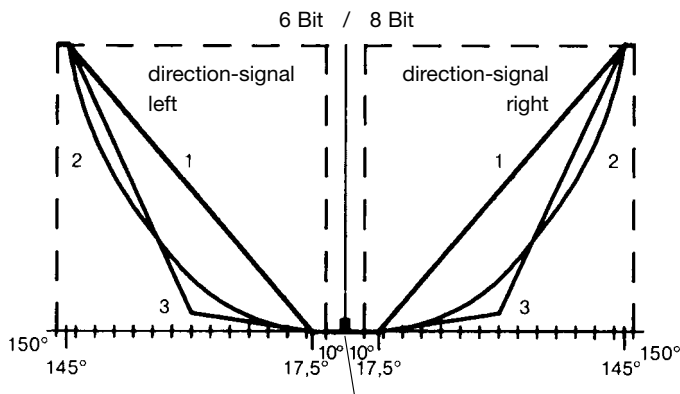

40	Cable Llycy 14 x 0,25 mm ² 2000 mm long wired on connector DA 15 with end splice					
41	Prepared for mounting encoder adjusting-angle switching-gear Δ encoder				(C)	
42	Prepared for mounting encoder adjusting-angle variable.				(C)	
43	Additional price per metre cable Llycy 14 x 0,25 mm ²					



Pos.	for mounting on: V 6 / D 64 / V 11 / S 2 / S 6 / N 6	Type-expansion	Weight gramm	Type	Price EURO
1	Opto-electronic encoder T 366 Output voltage impressed 0 – 10 Volt	OEC 2-3-□-1		C11□	
2					
3					
4	<p>□ = Output characteristic 1 = Linear 2 = Quadratic 3 = Progressive</p> <p>Technical data Power supply 18-30 V DC Output 0–10 V (+5 mA) Scanning 6 bit Gray-Code Rotation angle max. ± 150°</p>				
5	Opto-electronic encoder T 367 Output voltage impressed ± 10 Volt	OEC 2-3-□-2		C15□	
6					
7					
8	<p>□ = Output characteristic 1 = Linear 2 = Quadratic 3 = Progressive</p> <p>Technical data Power supply 18-30 V DC Output ±10 V (±5 mA) Scanning 6 bit Gray-Code Rotation angle max. ± 150°</p>				
40	Cable Llycy 14 x 0,25 mm ² 2000 mm long wired on connector DA 15 with end splice				
41	Prepared for mounting encoder adjusting-angle switching-gear Δ encoder			(C)	
42	Prepared for mounting encoder adjusting-angle variable			(C)	
43	Additional price per metre cable Llycy 14 x 0,25 mm ²				



Pos.	for mounting on: V 6 / D 64 / V 11 / S 2 / S 6 / N 6	Type-expansion	Weight gramm	Type	Price EURO
1	Opto-electronic encoder Output power impressed 4 – 20 mA T 368	OEC 2-3-□-5	410	C19□	
2	Opto-electronic encoder Output power impressed 0 – 20 mA T 368	OEC 2-3-□-8	410	C20□	
3					
4					
	<p>□ = Output characteristic 1 = Linear 2 = Quadratic 3 = Progressive</p> <p>Technical data Power supply 18-30 V DC Output 4/0–20 mA Scanning 6 bit Gray-Code Rotation angle max. ± 150°</p>				
5	Opto-electronic encoder T 369 Output power impressed ± 20 mA	OEC 2-3-□-6	410	C23□	
6					
7					
8					
	<p>□ = Output characteristic 1 = Linear 2 = Quadratic 3 = Progressive</p> <p>Technical data Power supply 18-30 V DC Output ±20 mA Scanning 6 bit Gray-Code Rotation angle max. ± 150°</p>				
40	Cable Llcy 14 x 0,25 mm² 2000 mm long wired on connector DA 15 with end splice				
41	Prepared for mounting encoder adjusting-angle switching-gear $\hat{=}$ encoder			(C)	
42	Prepared for mounting encoder adjusting-angle variable.			(C)	
43	Additional price per metre cable Llcy 14 x 0,25 mm²				



Pos.	for mounting on: V 6 / D 64 / V 11 / S 2 / S 6 / N 6		Type-expansion	Weight gramm	Type	Price EURO
1	Opto-electronic encoder	8 Bit Gray-Code T 496	OEC 4-1-1-2	820		
2		8 Bit Binary-Code T 496	OEC 4-2-1-2	820		
3		6 Bit Gray-Code T 496	OEC 4-3-□-2	820		
4		6 Bit Binary-Code T 496	OEC 4-4-□-2	820		
5		9 Bit Gray-Code T 497	OEC 4-5-□-2	820		
6		9 Bit Binary-Code T 497	OEC 4-6-□-2	820		

Technical data

Power supply 18-30 V DC, Output 6, 8 or 9 Bit, Scanning Gray-Code
Communication Profibus DP (DIN 19245 Part 3)
Ident.-No. 045 CH address 0-99 adjustable above selector-switch
Rotation angle max. ± 150° (360°), with connection for OEC 2
see catalog 1/241

□ = Output characteristic

- 1 = Linear
- 2 = Quadratic
- 3 = Progressive
- 4 = Linear one sided right turn
- 5 = Linear one sided left turn

for 1 axis-controller 1 PC.OEC4... is required

for 2 axis-controller 1 PC.OEC4... and 1PC.OEC2... see catalog 1/241 are required

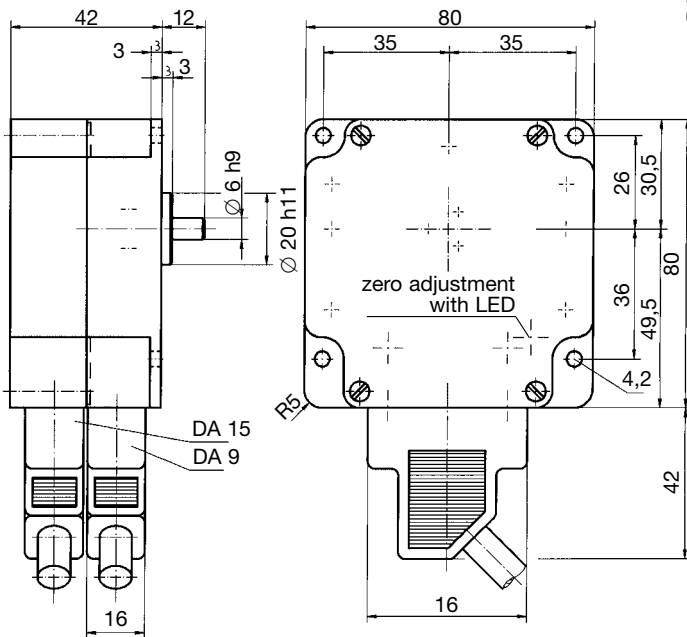
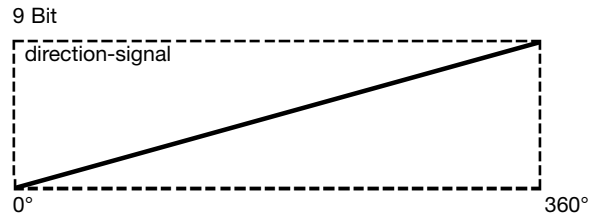
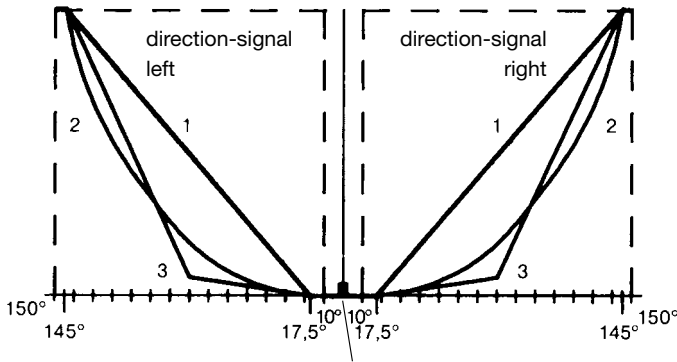









38	Profibus-cable FDPL2/F/P 1x 2 x 0,64mm ² 2000mm long wired on 2 connectors DE9					
39	Cable (power supply) for 1 axis-controller Llycy 2 x 0,25mm ² 2000mm long wired on connector DA15 with end splice					
40	Cable for 2 axis-controller Llycy 16 x 0,25mm ² x 450mm lang wired on 2 connectors DA15 for OEC4/OEC2 with cable (power supply) 2 x 0,25mm ² 2000mm long wired with end splice					
41	Prepared for mounting encoder adjusting-angle switching-gear Δ encoder					
42	Prepared for mounting encoder adjusting-angle variable					
43	Additional price per metre cable Llycy 14 x 0,25 mm ²					
44	Additional price per metre Profibus-cable FDPL2/F/P 1 x 2 x 0,64mm ²					

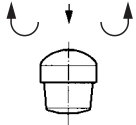

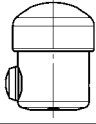
Pos.	for mounting on: V 6 / V 11 / D 64 / S 2 / S 6 / N 6	Type-expansion	Weight gramm	Type	Price EURO
2	Inductive transducer IG 1 T 440		850	I	
	<p>Technical data Mechanical life 2×10^7 switching cycles Input voltage AC 110 V, 50 Hz Output voltage AC 74 V, 50 Hz Transfer power max. 3 VA Rotation angle, max. $\pm 90^\circ$</p>				
3	Inductive transducer IG 1 with matching electronic Ey / 55 ± 10 V DC T 434			I	
20	Transformer with capacitor 4 mF for connection 220 V 50 Hz	MTD			
41	Prepared for mounting transducer adjusting-angle switching-gear $\hat{=}$ transducer			(I)	
42	Prepared for mounting transducer adjusting-angle variable.			(I)	

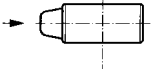
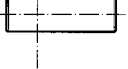
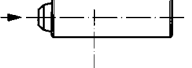
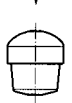

Pos.				Contact-complement	Weight gramm	Type	Price EURO
1		Knob solid 42 mm Ø	KBAD 66		35	GK1	
2		Knob 42 mm Ø with push button top	KHS/177	1 change over contact 0,5 A 250 V AC 15 1,5 A 24 V DC 13	25	GK2	
3		Knob 42 mm Ø with 3 push down button operated by twisting the upper knob half	KBAD/230	3 change over contact 0,5 A 250 V AC 15 1,5 A 24 V DC 13	170	GK3	
4		Knob 25 mm Ø with M 6	KBAD 271		10	GK4	
5		Knob 27 mm Ø with M 8	KBAD 302		15	GK5	
6		Knob 42 mm Ø with 1 push button top 1NO+1NC 1 push button side 1NO	KBAD/605	0,5 A 250 V AC 15 0,1 A 24 V DC 13	170	GK6	
7		Knob solid 29 mm Ø	KBAD/141		70	GS6	
8		Knob 29 mm Ø with push button top	KBAD/210	1 change over contact 0,5 A 250 V AC 15 1,5 A 24 V DC 13	60	GS7	
9		T-grip solid 28 mm Ø x 58 mm	KBAD 148		50	Q8	
10		T-grip 28 mm Ø x 58 mm with push button side	KBAD 147	1 change over contact 0,5 A 250 V AC 15 1,5 A 24 V DC 13	60	Q9	
11		T-grip solid 28 mm Ø x 80 mm	KBAD 355		50	Q10	
12		T-grip 28 mm Ø x 98 mm with push button side	KBAD 329	1 change over contact 0,5 A 250 V AC 15 1,5 A 24 V DC 13	60	Q11	
13		Knob 42 mm Ø with sensorbutton regulator electronic board EY/92 1NO	KBAD/4 76		150	GSE	
21		Cable 4 x 0,25 mm ² x 450 mm long, wired included Pos. 1 – 12 Additional price per metre cable 4-pole					



Type → operator handles

switch devices ↓

	GK 1	GK2	GK3	GK4	GK5	GK6	GS6	GS7	Q8	Q9	Q10	Q11	GSE	B1	B2	B3	B4	B5	B6	B7/8	B9	B10	B 20
V 6	X		X			X			X	X			X	X		X		X		X	X		X
VV 6	X		X			X			X	X			X	X		X		X		X	X		X
V 11	X		X			X			X	X			X	X			X	X	X				
V 5	X								X					X				X					
VV 5	X		X			X			X	X			X	X		X		X	X	X	X		
V 8/ VV 8	X	X	X			X			X	X			X	X	X	X		X		X	X		X
V 85/ VV 85	X	X	X						X	X			X	X	X	X		X		X	X		X
V 10	X				X	X	X	X					X				X	X	X				
V 14	X	X	X	X		X	X						X				X	X					
V 3	X								X					X				X					
D/ DD 64	X								X	X												X	
D 8	X								X	X												X	
D 3	X											X	X										
S 2/ SS 2	X		X				X	X	X	X			X	X				X	X				
S 21/ SS 21	X		X			X	X	X	X	X			X	X				X	X				
S 22/ SS 22	X		X				X	X	X	X			X	X				X	X				
S 23	X											X											
S 3	X											X	X										
S 14	X	X	X	X		X	X						X				X	X					
S 6	X	X	X						X	X				X				X					



Type → **Mechanical zero interlock with command devices**
T=dead man's button, H=signal button, D=push button, DV=flat push button, DR=push button operated by twisting

switch devices ↓	Type																		
	MN T	M H	MP H	M D	MP D	M DV	MP DV	MP DR											
V 6	X	X	X		X		X	X											
V 61 V 62	X	X	X	X	X	X	X	X											
VV 6	X	X	X		X		X	X											
VV 61 VV 62	X	X	X	X	X	X	X	X											
V 11	X		X		X		X	X											
V 5 VV 5		X	X	X	X	X	X												
V 8 VV 8	X	X	X		X		X	X											
V 85 VV 85																			
V 25																			
V 10																			
V 14	X	X	X	X	X	X	X	X											
D 64 DD 64	X	X	X	X	X	X	X	X											
D 8																			
S 14	X	X	X	X	X	X	X	X											
S 2 SS 2		X		X		X													
S 21 SS 21		X		X		X													
S 22 SS 22		X		X		X													
S 23		X		X		X													

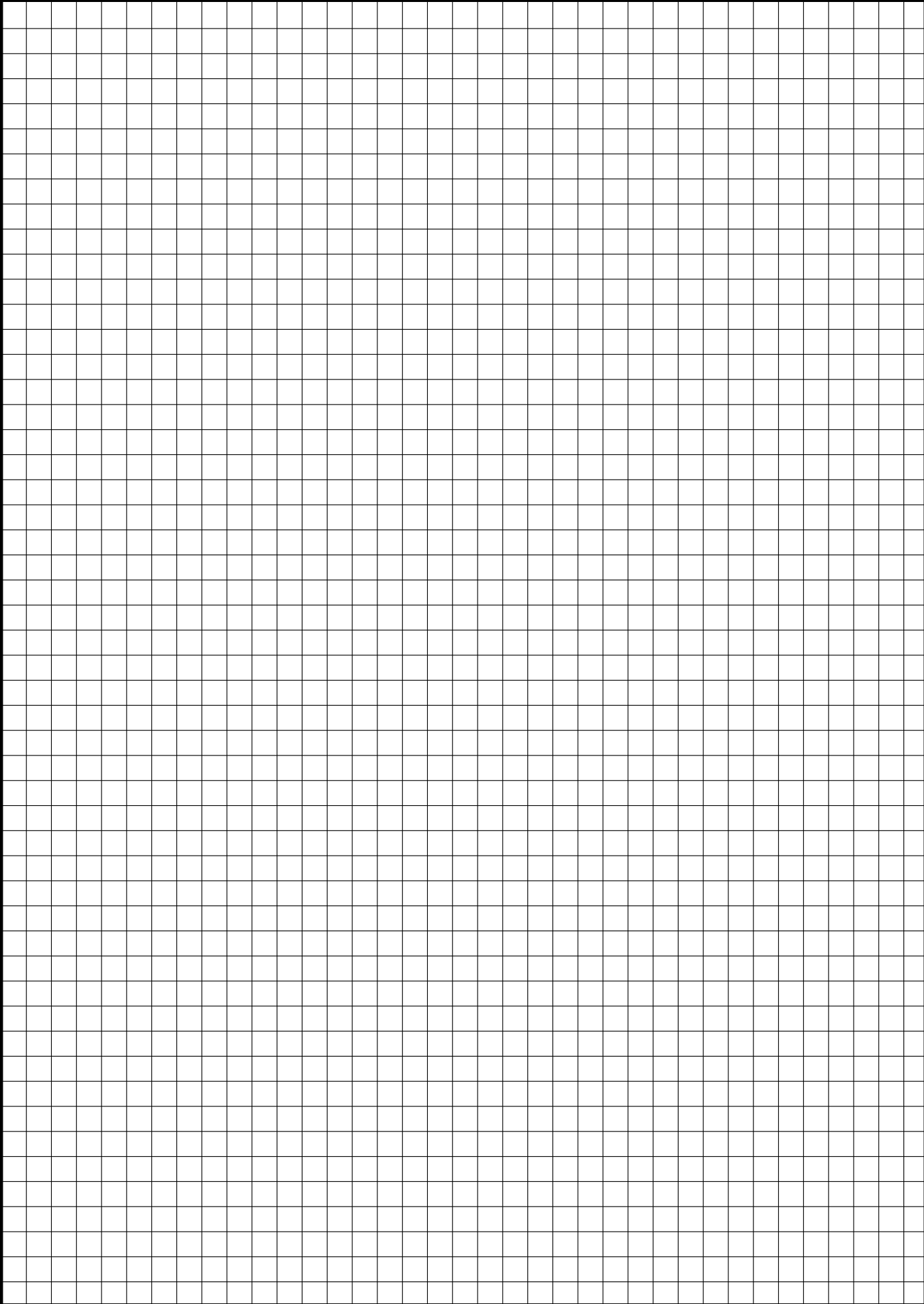

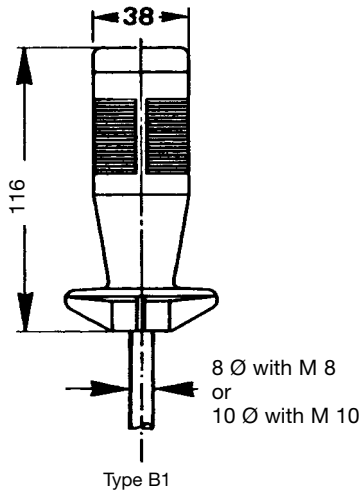

The palm grip B 1 is an actuating element for our multi-axis and single-axis controller. It can also be used as an actuating element with hydraulic drives. Push buttons, rocker switches, e.t.c., can also be fitted to suit appropriate requirements. These devices have micro changeover contacts.

The palm grip has a highly flexible cable 4 (8) x 0,25 mm² x 450 mm long.

The mounting piece for the drive rod can be supplied with a tapped hole M 8 or M 10 (standard = M 10).

The palm grip B 1 is made of PA plastic and is black in colour.

Contact complement 2 A 250 V AC 15 / 3 A 24 V DC 13
or 0,5 A 250 V AC 15 / 1,5 A 24 V DC 13

Permissible ambient temperature Operating -40°C to +60°C
Storage -50°C to +80°C

Climate resistance
Damp heat constant DIN IEC 68 part 2-3
Damp heat cyclic DIN IEC 68 part 2-30
Degree of protection front IP 54 IEC 529 DIN 40050

Pos.				Contact-complement	Weight gramm	Type	Price EURO
1		Without built in		KBAD / 22	100	B 1	
2 3 4		Rocker switch top tast-0-tast T-0-T installed Pos. 1+2 Rocker switch top tast-0-rest T-0-R installed Pos. 1+2 Rocker switch top rest-0-rest R-0-R installed Pos. 1+2		KBAD / 46	2 change over contact 2 A 250 V AC 15	120	B 1 W
5		Rocker switch top tast-0-tast T-0-T installed Pos. 1+2 with push button side installed Pos. 5		KBAD / 49	2 change over contact 2 A 250 V AC 15 1 change over contact 0,5 A 250 V AC 15	130	B 1 WD
6		Rocker switch top tast-0-tast T-0-T installed Pos. 1+2 with 2 push button side installed Pos. 4+5		KBAD / 67	2 change over contact 2 A 250 V AC 15 2 change over contact 0,5 A 250 V AC 15	140	B 1 W2D
7 8		Push button top with mechanical operation installed Pos. 1 Push button top		KBAD / 27 KBAD / 25	1 change over contact 0,5 A 250 V AC 15	120 100	B 1 T B 1 D
9 10		Push button top with installed Pos. 1 1 push button side Push button top with installed Pos. 4+5 2 push button side		KBAD / 47	2 change over contact 0,5 A 250 V AC 15 3 change over contact 0,5 A 250 V AC 15	120 130	B 1 2D B 1 3D
11 12 13		1 push button side installed Pos. 3 2 push button side installed Pos. 4 3 push button side installed Pos. 5		KBAD / 50	change over contact 0,5 A 250 V AC 15	110 120 130	B 1 D B 1 2D B 1 3D
14		Push button top installed Pos. 1 with Rocker switch side tast-0-tast (protection IP 41) T-0-T installed Pos. 4+5		KBAD / 75	1 change over contact 0,5 A 250 V AC 15 2 change over contact 0,5A 250V AC 15	120	B 1 DW
15 16 17		Lever switch side 0-tast mechanical operation Lever switch side 0-tast 1 contact Lever switch side 0-tast 2 contacts		KBAD / 126 KBAD / 54	change over contact 2 A 250 V AC 15	150 120 130	B 1 KT B 1 K B 1 2K
21 22		Cable 4 res. 8 x 0,25 mm ² x 450 mm long wired included Pos. 1-17 Additional price per metre cable 4-pole Additional price per metre cable 8-pole					

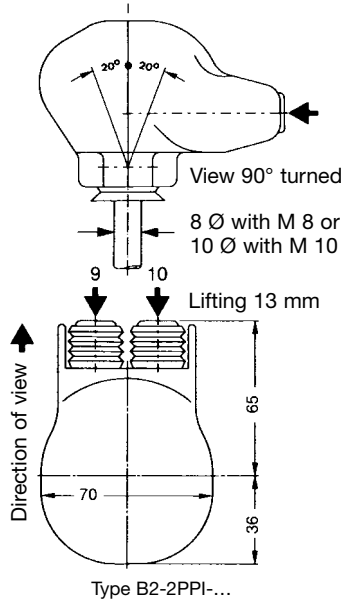

The palm grip B 2 is an actuating element for our multi-axis controller V 8. It can also be used as an actuating element for hydraulic drives. With each of the two push button one direction-contact (micro change over contact) also one potentiometer pushed. These palm grip realised the 3. direction 9-10 (3. axis) on our multi-axis controller V 8.

The palm grip has a highly flexible cable
8 x 0,25 mm² x 450 mm long.

The mounting piece for the drive rod can be adjusted steplessly up to 20° in all directions.

The palm grip B 2 is made of PA plastic and is black in colour.

Contact complement 0,5 A 110 V AC 15 res. 1,5 A 24 V DC 13
I min > 0,2 mA 2 V DC 12 Gold plated for max. load of 0,12 Watt (standard)

Permissible ambient temperature Operating -40°C to +60°C
Storage -50°C to +80°C

Climate resistance DIN IEC 68 part 2-3
Damp heat constant DIN IEC 68 part 2-30
Damp heat cyclic IP 54 IEC 529 DIN 40050
Degree of protection front

Pos.		Weight gramm	Type	Price EURO
1	Palm grip with mounting piece for control-handle	200	B 2	
2	Latch for mechanical interlock for the push buttons	30	M	
3	2 direction-contacts	30	2	
4	2 wire-wound potentiometer T 239 linear life 5 x 10 ⁶ switching cycles resistance 1,2,5 kOhm 1 Watt wiper current max. 10 mA	60	PP	
5	2 conductive-plastic potentiometer T 301 linear life 10 ⁷ switching cycles resistance 1,2,5 kOhm 0,5 Watt wiper current max. 1 mA	50	PP	
6	more potentiometer e.t.c. see catalog 1/240			
10	Impedance converter Input ±15 Volt, Output ±10 V /5 mA	50	I	
22	Cable 8 x 0,25 mm ² x 450 mm long wired included Pos. 1-10 Additional price per metre cable 8-pole			

Example for type-sign

Palm grip

Mechanical interlock

No. of contacts

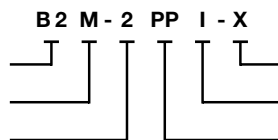

Special please describe

Impedance converter

Potentiometer e.t.c.



Type B32DWKPA11-...

The palm grip B 3 is an actuating element for our multi-axis controller V 8, VV 8, V 6, VV 6, VV 5. It can also be used as an actuating element for hydraulic drives.
Push buttons, rocker switches, e.t.c., can also be fitted to suit appropriate requirements. The drives with potentiometer PA 11/12 and PA 13 realised the direction 11-12 resp. 13-14 (3. resp. 4 axis) on our multi-axis controllers.

The palm grip has a highly flexible single wire 0,1 mm² x 450 mm long.

The mounting piece for the drive rod can be supplied with a tapped hole 12 or 10 mm (standard = 12 mm).

The palm grip B 3 is made of PA plastic and is black in colour.

Contact complement 0,5 A 110 V AC 15 res. 1,5 A 24 V DC 13 I min > 0,2 mA 2 V DC 12 Gold plated for max. load of 0,12 Watt (standard)

Permissible ambient temperature Operating -40°C to +60°C
Storage -50°C to +80°C

Climate resistance
Damp heat constant DIN IEC 68 part 2-3
Damp heat cyclic DIN IEC 68 part 2-30
Degree of protection front IP 65 IEC 529 DIN 40050

Pos.		Weight gramm	Type	Price EURO
1	Palm grip with mounting piece for control-handle	200	B 3	
2	Push button 1 NO installed Pos. 1, 2, 3, 4, 5, 6 color red RD, black BK, yellow YE, green GN, blue BU	20	D	
3	Rocker switch tast-0-tast T-0-T 2 NO installed Pos. 1 + 2	30	W	
4	Rocker switch tast-0-rest T-0-R 2 NO installed Pos. 1 + 2	30	W	
5	Rocker switch rest-0-rest R-0-R 2 NO installed Pos. 1 + 2	30	W	
6	Lever switch 1 NO	30	K	
7	Sliding switch tast-0-tast T-0-T 2 NO installed Pos. 13 + 14	40	ST	
8	Sliding switch rest-0-rest R-0-R 2 NO installed Pos. 13 + 14	40	SR	
9	Push button with 2 steps Latch for mechanical installed Pos. 11 + 12 zero interlock 4 contacts arrangement MS 212 see catalog 5/001	90	ZD	
11	Drive with potentiometer PA 11 actuating by rocker wheel installed Pos. left or right with spring return in the centre position 1 conductive-plastic potentiometer T 375 with centre tap Linear 10 ⁷ switching cycles resistance 2 x 5 kOhm 0,5 Watt wiper-current max. 1 mA 2 direction-contacts	90	PA 11	
12	Drive with potentiometer PA 12 actuating installed Pos. 11 + 12 by push button (details exactly PA 11)	90	PA 12	
13	Drive with potentiometer PA 13 actuating by rotating palm grip left resp. right with spring return in the centre position 1 conductive-plastic potentiometer T 375 with centre tap Linear 10 ⁷ switching cycles resistance 2 x 5 kOhm 0,5 Watt wiper current max. 1 mA, 2 direction-contacts	90	PA 13	
15	Drive with potentiometer PA 15 actuating by lever switch with spring return in 0-position, 1 conductive-plastic potentiometer T 375 Linear 10 ⁷ switching cycles resistance 5 kOhm 0,5 Watt wiper current max. 1 mA, 1 direction-contact	90	PA 15	
20	Vibrator button actuating through solenoid 24 V DC impulse signal 100% duty cycle factor (e.g. indication of cable movement)	60	V	
21	Sensor button and res. or annexed with a regulator electronic board EY/42-10 or -11 24 V DC (separate)	20	SE	
22				
23				
30	Bellow for palm grip B 3 drawing No. KMD 109 required for multi-axis controller V 8, VV 8			
31	Bellow for palm grip B 3 drawing No. KMD 190 and front plate with 4 screws M5 x 15 (for mounting the bellow) drawing No. KBF 905 required for multi-axis controller V 6, VV 6, VV 5			
32				
33				

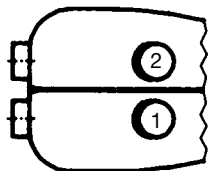
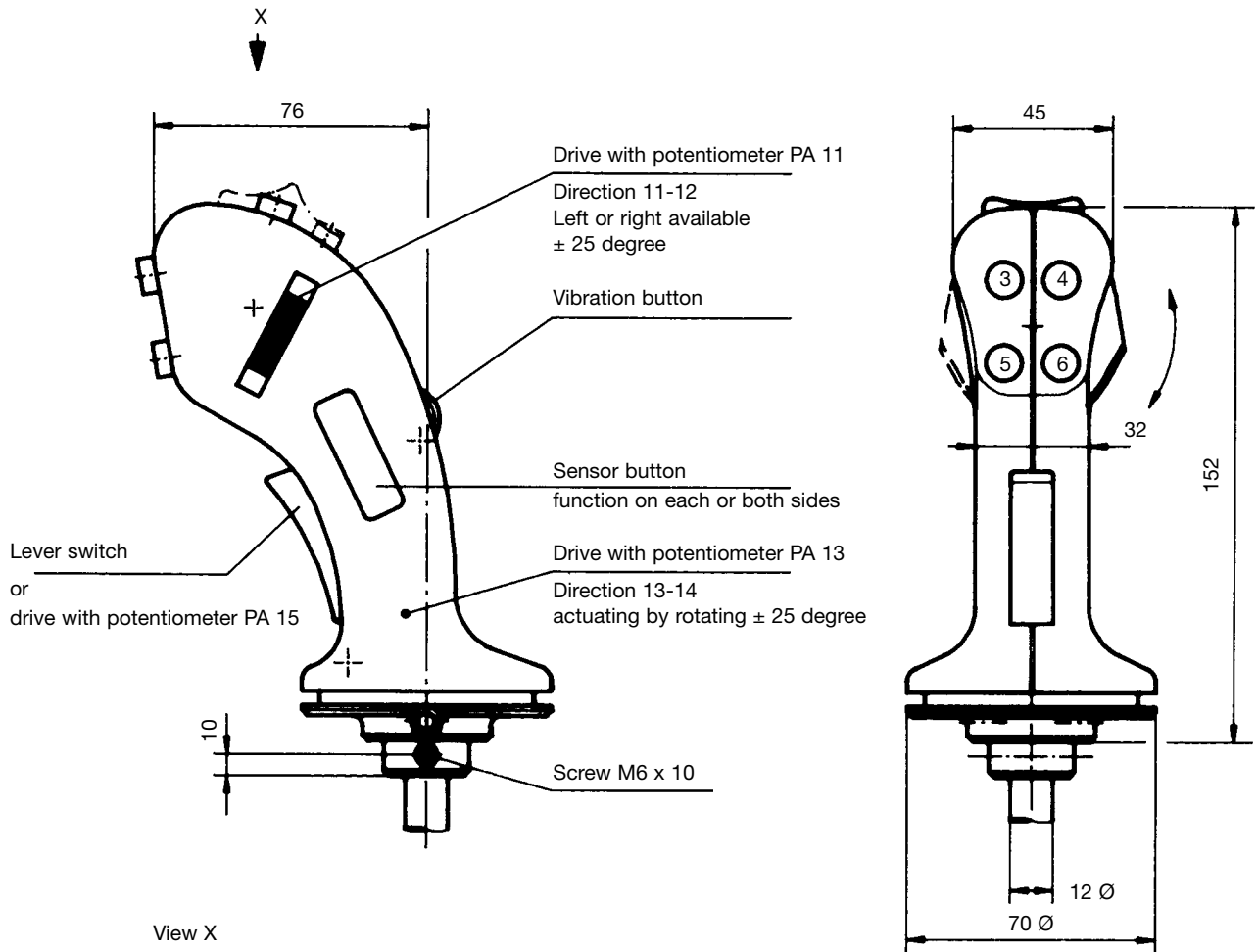

Edition:
Push button

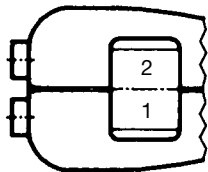

Edition:
Rocker switch
(installed Pos. 3, 4 inapplicable)

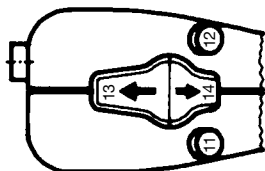

Edition:
Sliding switch installed Pos. 13, 14
installed Pos. 1, 2, 4, 6 inapplicable
Drive with potentiometer PA 12 direction 11 - 12 installed Pos. 11, 12
PA 11 inapplicable
Push button with 2 steps ZD installed Pos. 11 - 12
PA 11, 12 inapplicable

Edition:
Vibrator button only one
Drive with potentiometer PA 13 version
Drive with potentiometer PA 15 possible

Example for type-sign

- Palm grip
- Push button
- Rocker switch
- Lever switch

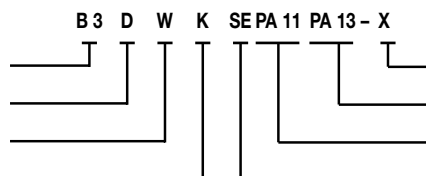

- Special please describe
- Drive with potentiometer PA 13
- Drive with potentiometer PA 11
- Sensor button

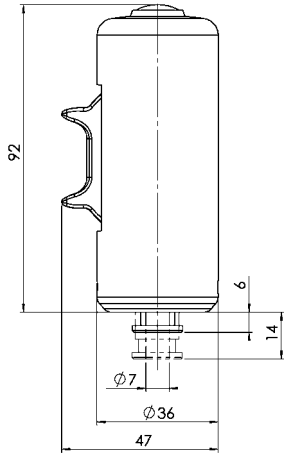

Type B4DPA11-...

The palm grip B 4 is an actuating element for our multi-axis controller V 10, V 11, V 14. It can also be used as an actuating element for hydraulic drives. Push buttons, rocker switches, e.t.c., can also be fitted to suit appropriate requirements. The drive with potentiometer PA 11 realised the direction 11-12 (3. axis) on our multi-axis controllers.

The palm grip has a highly flexible single wire 0,1 mm² x 450 mm long. The mounting piece for the drive rod can be supplied with a tapped hole 8 mm. The palm grip B 4 is made of PA plastic and is black in colour.

**Contact complement 0,5 A 110 V AC 15 res. 1,5 A 24 V DC 13
I min > 0,2 mA 2 V DC 12 Gold plated for max. load of 0,12 Watt (standard)**

Permissible ambient temperature Operating -40°C to +60°C
Storage -50°C to +80°C

Climate resistance
Damp heat constant DIN IEC 68 part 2-3
Damp heat cyclic DIN IEC 68 part 2-30
Degree of protection front IP 65 IEC 529 DIN 40050

Pos.				Weight gramm	Type	Price EURO
1	Palm grip with mounting piece for control-handle			120	B 4	
2	Push button 1 NO 100 mA 24 V DC 13			20	D	
3						
5						
6						
10						
11	Drive with potentiometer PA 11 actuating by rocker wheel with spring return in the centre position 1 conductive-plastic potentiometer T 394 with centre tap Linear 10' switching cycles resistance 2 x 5 kOhm 0,5 Watt wiper current max. 1 mA 2 direction-contacts			90	PA 11	
30						
31						
32						
33						

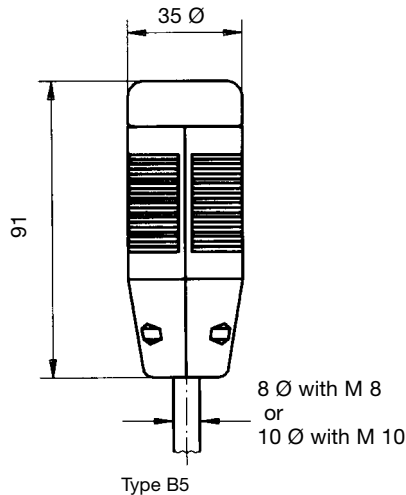

The palm grip B 5 is an actuating element for our multi-axis and single-axis controller. It can also be used as an actuating element for hydraulic drives. Push buttons, rocker switches, e.t.c., can also be fitted to suit appropriate requirements.

The palm grip has a highly flexible cable 4 (8) x 0,25 mm² x 450 mm long.

The mounting piece for the drive rod can be supplied with a tapped hole M 8 or M 10 (standard = M 10).

The palm grip B 5 is made of PA plastic and is black in colour.

Contact complement 2 A 250 V AC 15 / 3 A 24 V DC 13
or 0,5 A 250 V AC 15 / 1,5 A 24 V DC 13

Permissible ambient temperature Operating -40°C to +60°C
Storage -50°C to +80°C

Climate resistance
Damp heat constant
Damp heat cyclic
Degree of protection front
DIN IEC 68 part 2-3
DIN IEC 68 part 2-30
IP 54 IEC 529 DIN 40050

Pos.				Contact-complement	Weight gramm	Type	Price EURO
1		without built in		KBAD / 254		B 5	
2 3 4		Rocker switch top tast-0-tast Rocker switch top tast-0-rest Rocker switch top rest-0-rest	T-0-T installed Pos. 1+2 T-0-R installed Pos. 1+2 R-0-R installed Pos. 1+2	KBAD / 248	2 change over contact 2 A 250 V AC 15	B 5 W	
5		Rocker switch top tast-0-tast with push button side	T-0-T installed Pos. 1+2 installed Pos. 4	KBAD / 294	2 change over contact 2 A 250 V AC 15 1 change over contact 0,5A 250 V AC 15	B 5 WD	
7 8		Push button top mechanical operation Push button top	installed Pos. 1	KBAD / 311 KBAD / 250	1 change over contact 0,5 A 250 V AC 15	B 5 T B 5 D	
9		Push button top with 1 push button side	installed Pos. 1 installed Pos. 4	KBAD / 252	2 change over contact 0,5 A 250 V AC 15	B 5 2D	
11 12		1 push button side 2 push button side	installed Pos. 3 installed Pos. 4	KBAD / 246	change over contact 0,5 A 250 V AC 15	B 5 D B 5 2D	
21 22		Cable 4 res. 8 x 0,25 mm ² x 450 mm long wired included in Pos. 1-12 Additional price per metre cable 4-pole Additional price per metre cable 8-pole					

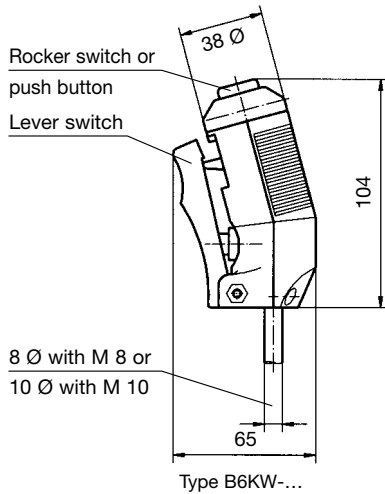

The palm grip B 6 is an actuating element for our multi-axis and single-axis controller. It can also be used as an actuating element with hydraulic drives. Push buttons, rocker switches, e.t.c., can also be fitted to suit appropriate requirements. These devices have micro changeover contacts.

The palm grip has a highly flexible cable 4 (8) x 0,25 mm² x 450 mm long.

The mounting piece for the drive rod can be supplied with a tapped hole M 8 or M 10 (standard = M 10).

The palm grip B 6 is made of PA plastic and is black in colour.

Contact complement 2 A 250 V AC 15 / 3 A 24 V DC 13
or 0,5 A 250 V AC 15 / 1,5 A 24 V DC 13

Permissible ambient temperature Operating -40°C to +60°C
Storage -50°C to +80°C

Climate resistance
Damp heat constant DIN IEC 68 part 2-3
Damp heat cyclic DIN IEC 68 part 2-30
Degree of protection front IP 54 IEC 529 DIN 40050

Pos.			Contact-complement	Weight gramm	Type	Price EURO
1		with built in lever switch side 0-tast	1 change over contact 0,5 A 250 V AC 15	120	B 6 K	
2		Lever switch side 0-tast				
3		with rocker switch top tast-0-tast T-0-T	3 change over contact			
4		with rocker switch top tast-0-rest T-0-R	0,5 A 250 V AC 15	130	B 6 KW	
		with rocker switch top rest-0-rest R-0-R				
5		Lever switch side 0-tast with push button top	2 change over contact 0,5 A 250 V AC 15	130	B 6 KD	
21		Cable 4 res. 8 x 0,25 mm ² x 450 mm long wired included Pos. 1-5				
22		Additional price per metre cable 4-pole Additional price per metre cable 8-pole				





Type B76DV-...

Type B86DV-...

The palm grip B 7 is an actuating element for our multi-axis controller V 8, VV 8, V 6, VV 6, VV 5 design left, B 8 for design right.
It can also be used as an actuating element for hydraulic drives.
Push buttons, rocker switches, e.t.c., can also be fitted to suit appropriate requirements.

The palm grip has a highly flexible single wire 0,1 mm² x 450 mm long.

The mounting piece for the drive rod can be supplied with a tapped hole 12 or 10 mm (standard = 12 mm).

The palm grip B 7/8 is made of PA plastic and is black in colour.

Contact complement 0,5 A 110 V AC 15 res. 1,5 A 24 V DC 13
I min > 0,2 mA 2 V DC 12 Gold plated for max. load of 0,12 Watt (standard)

Permissible ambient temperature Operating -40°C to +60°C
Storage -50°C to +80°C

Climate resistance
Damp heat constant DIN IEC 68 part 2-3
Damp heat cyclic DIN IEC 68 part 2-30
Degree of protection front IP 65 IEC 529 DIN 40050

Pos.		Contact-complement	Weight gramm	Type	Price EURO
1	Palm grip with mounting piece for control-handle design left		200	B 7	
2	Palm grip with mounting piece for control-handle design right		200	B 8	
3	Push button 1 NO installed Pos. 1, 2, 3, 4, 5, 6, 7, 8 color red RD, black BK, yellow YE, green GN, blue BU, white WH		20	D	
4	Rocker switch tast-0-tast T-0-T 2 NO installed Pos. 2, 3, 4		30	W	
5	Rocker switch tast-0-rest T-0-R 2 NO installed Pos. 2, 3, 4		30	W	
6	Rocker switch rest-0-rest R-0-R 2 NO installed Pos. 2, 3, 4		30	W	
7	Lever switch 1 NO		30	K	
20	Vibrator button actuating through solenoid 24 V DC impulse signal 100% duty cycle factor		60	V	
21	Sensor button and res. or annexed with a regulator electronic board EY / 42-10 or -11 24 V DC (separate)		20	SE	
22					
23					
30	Bellow for palm grip B 7/8 drawing No. KMD 109 required for multi-axis controller V 8, VV 8				
31	Bellow for palm grip B 7/8 drawing No. KMD 190 and front plate with 4 screws M5 x 15 (for mounting the bellow) drawing No. KBF 905 required for multi-axis controller V 6, VV 6, VV 5				
32					
33					



B 7

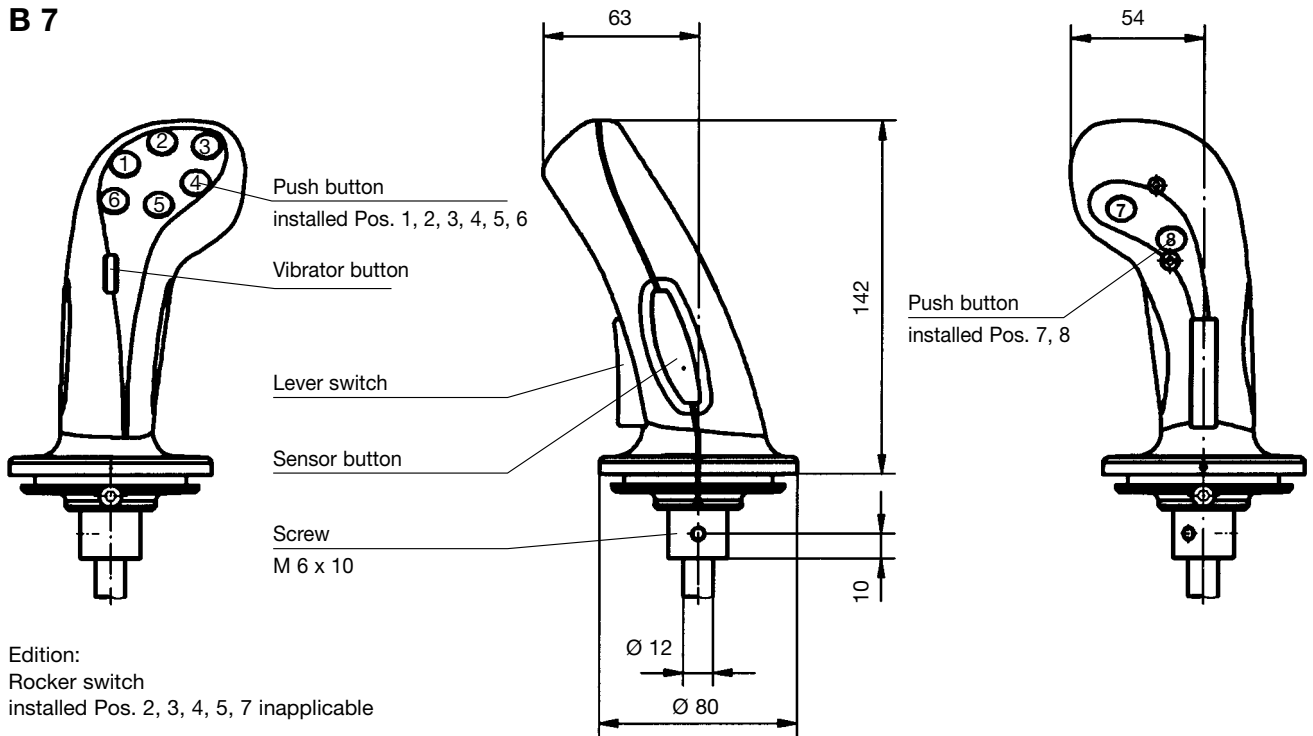

Edition:
Rocker switch
installed Pos. 2, 3, 4, 5, 7 inapplicable

B 8

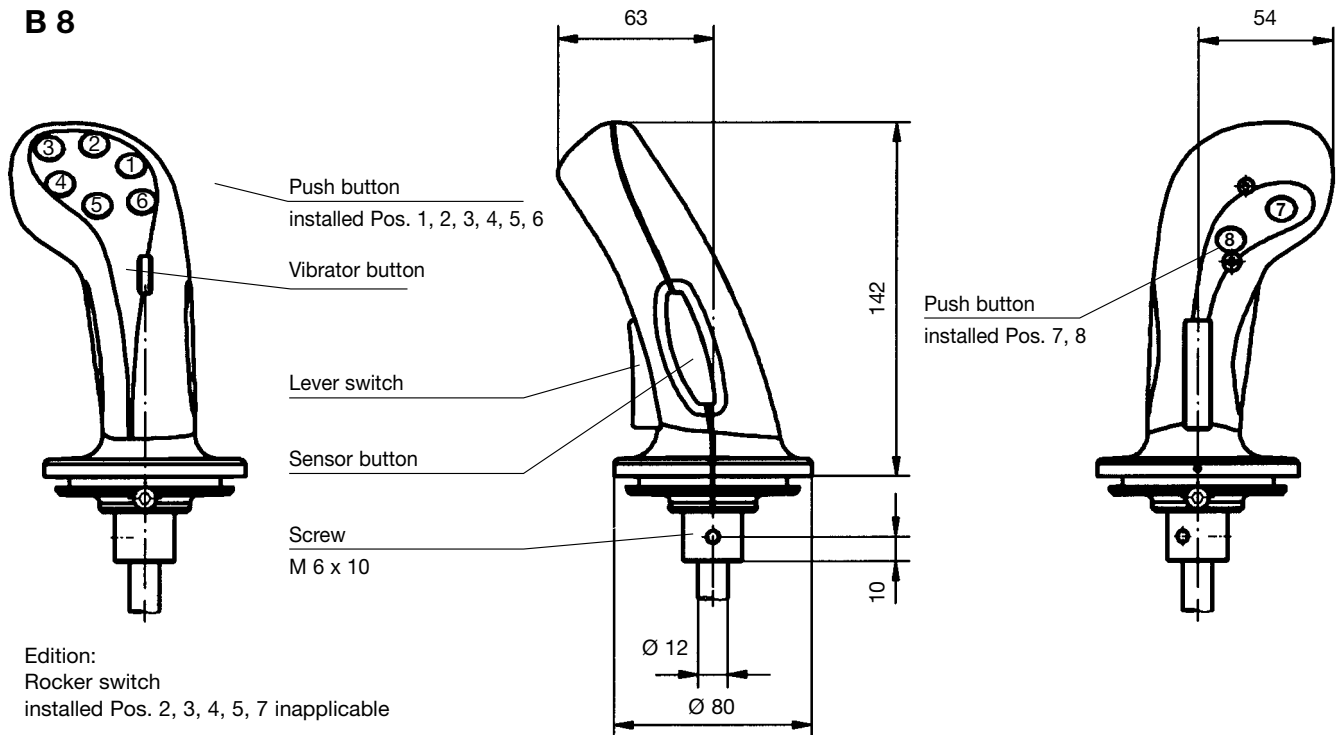

Edition:
Rocker switch
installed Pos. 2, 3, 4, 5, 7 inapplicable

Example for type-sign

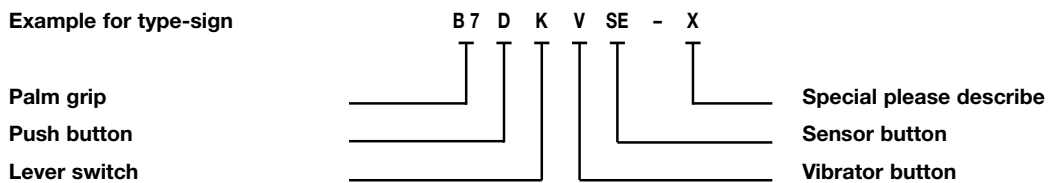

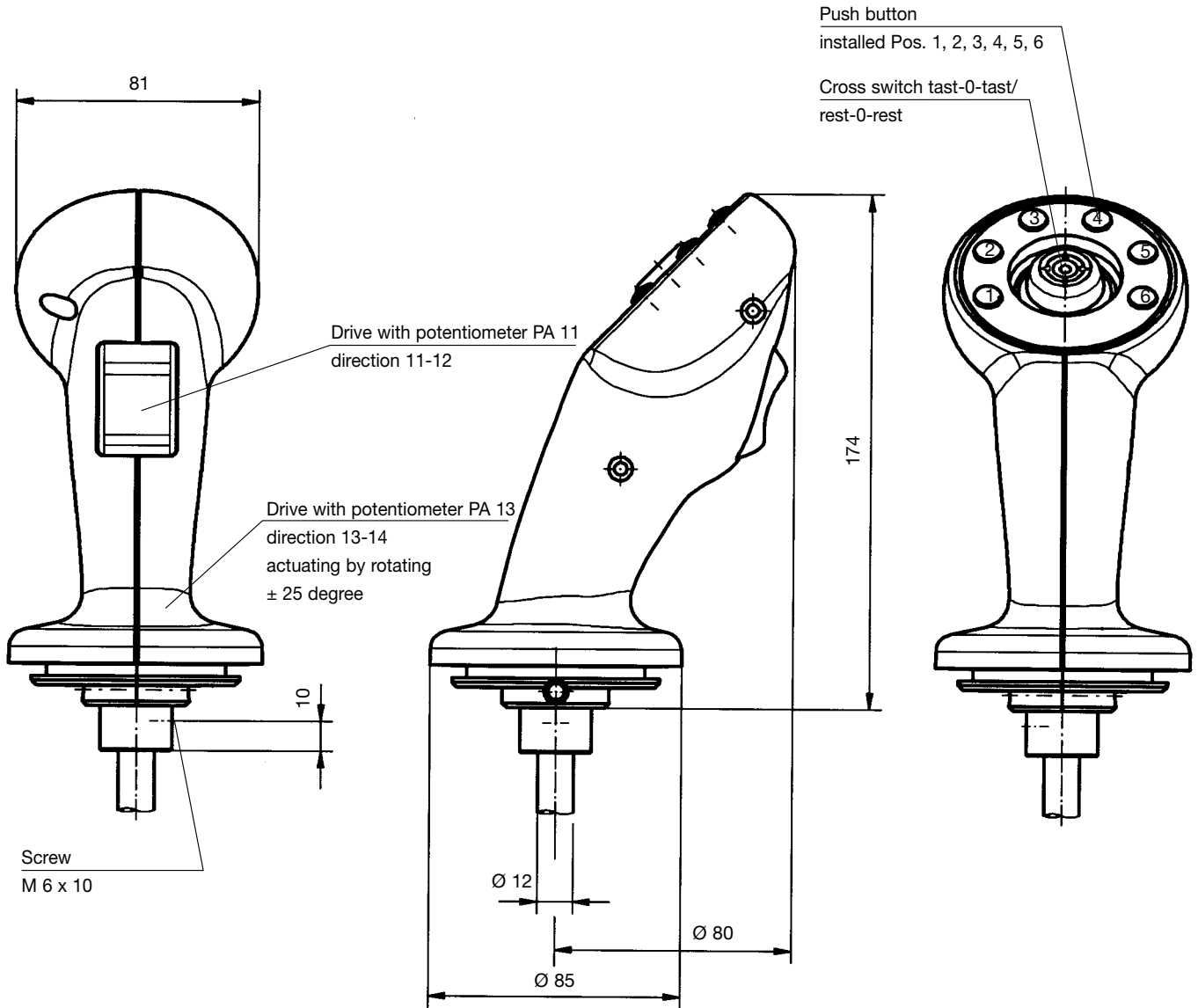

Example for type-sign

B 9 D KT PA 11 PA 13 - X

Palm grip
Push button
Cross switch



Special please describe
Drive with potentiometer PA 13
Drive with potentiometer PA 11



Type B10.1-13DW-...

The palm grip B 10-1 is an actuating element for double-handle controller D 64, DD 64, D8. Control-handle left, B10-2 for control-handle right. It can also be used as an actuating element for hydraulic drives. Push buttons, rocker switches, e.t.c., can also be fitted to suit appropriate requirements.

The palm grip has a highly flexible single wire 0,1 mm² x 450 mm long.

The mounting piece for the drive rod can be supplied with a tapped hole 10 mm. The palm grip B 10 is made of PA plastic and is black in colour.

**Contact complement 0,5 A 110 V AC 15 res. 1,5 A 24 V DC 13
I min > 0,2 mA 2 V DC 12 Gold plated for max. load of 0,12 Watt (standard)**

Permissible ambient temperature	Operating	-40°C to +60°C
	Storage	-50°C to +80°C
Climate resistance		
Damp heat constant		DIN IEC 68 part 2-3
Damp heat cyclic		DIN IEC 68 part 2-30
Degree of protection front		IP 65 IEC 529 DIN 40050

Pos.		Contact-complement	Weight gramm	Type	Price EURO
1	Palm grip with mounting piece for control-handle left		100	B 10-1	
2	Palm grip with mounting piece for control-handle left with annex component		130	B 10-1-1	
3	Palm grip with mounting piece for control-handle right		100	B 10-2	
4	Palm grip with mounting piece for control-handle right with annex component		130	B 10-2-2	
5	Push button 1 NO B 10-1 installed Pos. 1, 2, 3 B 10-2 installed Pos. 4, 5, 6		30	D	
6	Rocker switch tast-0-tast T-0-T 2 NO		30	W	
7	Rocker switch tast-0-rest T-0-R 2 NO		30	W	
8	Rocker switch rest-0-rest R-0-R 2 NO		30	W	
20	Vibrator button actuating through solenoid 24 V DC impulse signal 100% duty cycle factor		60	V	



B 10-1

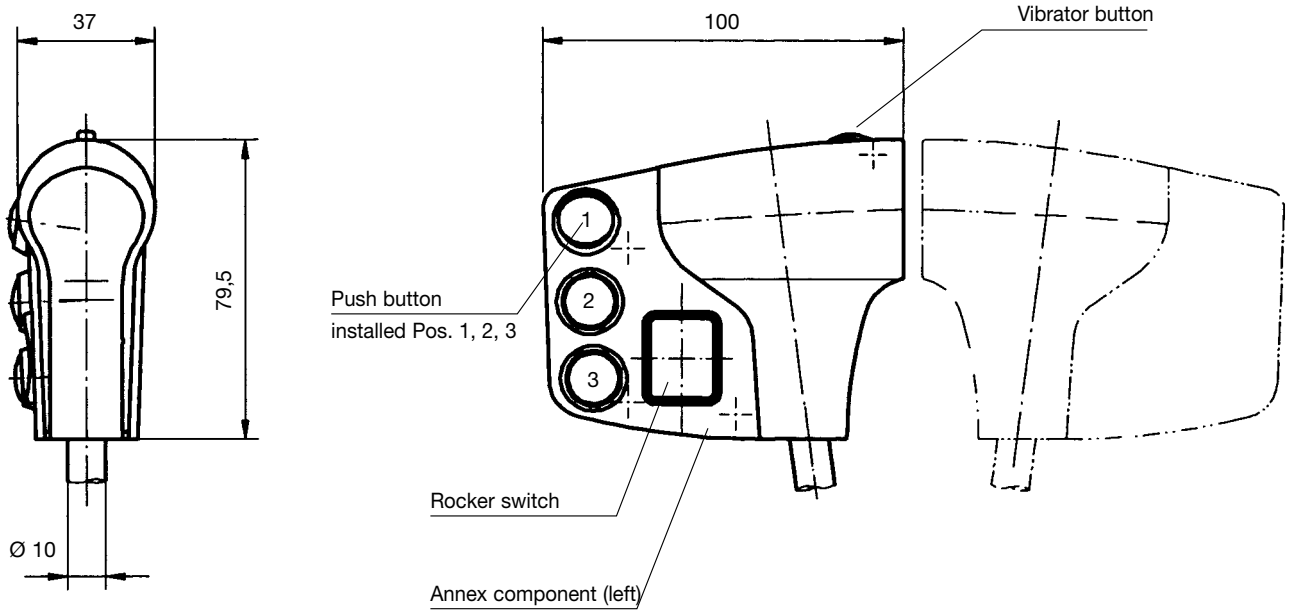

B 10-2

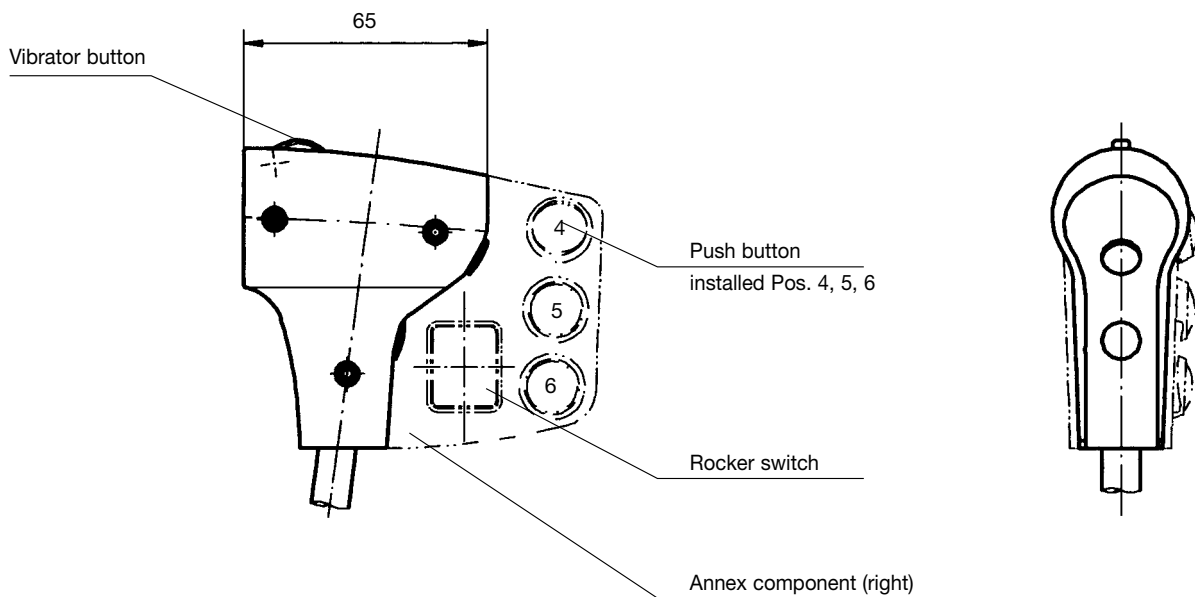

Example for type-sign

B 10-1 - 1 D W V - X

Palm grip

Palm grip with annex component

Push button



Special please describe

Vibrator button

Rocker switch



Type B142D-...

Type B152D-...

The palm grip B 14 is an actuating element for our multi-axis controller V 8, VV 8, V 6, VV 6, VV 5 design left, B 15 for design right.
It can also be used as an actuating element for hydraulic drives.
Push buttons, rocker switches, e.t.c., can also be fitted to suit appropriate requirements.

The palm grip has a highly flexible single wire 0,1 mm² x 450 mm long.

The mounting piece for the drive rod can be supplied with a tapped hole 12 or 10 mm (standard = 12 mm).

The palm grip B 14/15 is made of PA plastic and is black in colour.

Contact complement 0,125 A 110 V AC 15 res. 0,1 A 24 V DC 13

Permissible ambient temperature Operating -40°C to +60°C
Storage -50°C to +80°C

Climate resistance DIN IEC 68 part 2-3
Damp heat constant DIN IEC 68 part 2-30
Damp heat cyclic IP 65 IEC 529 DIN 40050
Degree of protection front

Pos.		Contact-complement	Weight gramm	Type	Price EURO
1	Palm grip with mounting piece for control-handle design left		200	B 14	
2	Palm grip with mounting piece for control-handle design right		200	B 15	
3	Push button 1 NO installed Pos. 1, 2 color red RD, black BK, yellow YE, green GN, blue BU, white WH		20	D	
30					
31					
32					
33					



B 14 (left)

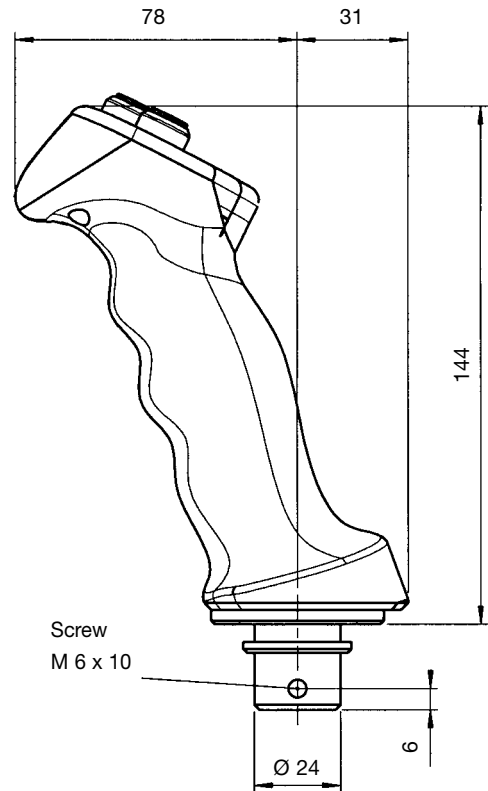
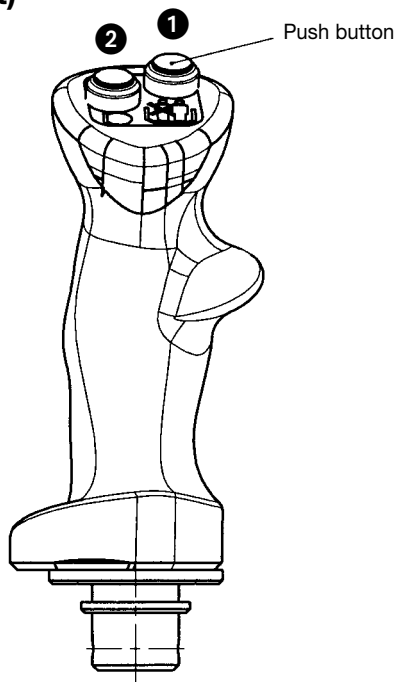

B 15 (right)

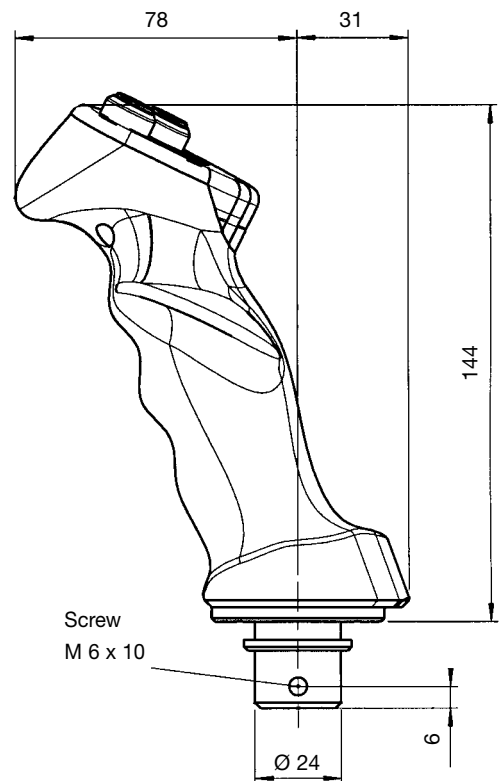
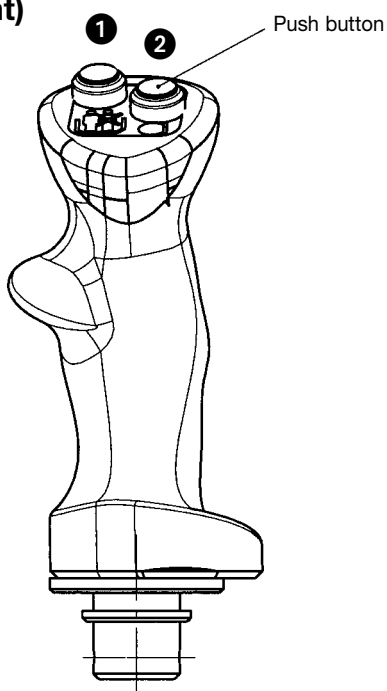

Example for type-sign

Palm grip
Push button

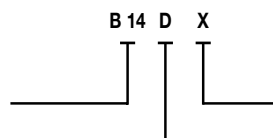

Special please describe



Type B 20

The Palm grip B 20 is an actuating element for our multi-axis controller V 8, VV 8, V 85, VV 85, V6, VV6. It can also be used as an actuating element for hydraulic drives. Push buttons, rocker switches, etc. can also be fitted to suit appropriate requirements. The palm grip has a highly flexible wire 0,1 mm² x 450 mm long. The mounting piece for the drive rod can be supplied with a tapped hole 12 mm. The palm grip B 20 is made of PAGF35 plastic and is black in colour.

permissible ambient temperature	operating -40° C bis +60° C
	storage -50° C bis +80° C
climate resistance	
damp heat constant	DIN IEC 68 part 2-3
damp heat cyclic	DIN IEC 68 part 2-30
degree of protection front	IP 65 IEC 529 DIN 40050

Pos.			Type-expansion	Weight gramm	Type	Pice EURO
1	Palm grip with mounting piece for control handle with hand rest left or right				B 20	
2	Push button	1 NO			D	
3	Push button	1 NO	S 59	1,5 A 24 V DC 13 0,4 A 24 V DC 13	D	
4						
5						
6						
7						
	colour red RD, black BK, yellow YE, green GN, blue BU					
8	Rocker switch tast-0-tast	T-O-T 2 NO	KEM 92	1,5 A 24 V DC 13	VV	
9	Rocker switch tast-0-rest	T-O-R 2 NO	KEM 92	1,5 A 24 V DC 13	VV	
10	Rocker switch rest-0-rest	R-O-R 2 NO	KEM 92	1,5 A 24 V DC 13	VV	
11	Lever switch	1 NO		1,5 A 24 V DC 13	K	
12	Cross switch tast-0-tast	T-O-T / T-O-T 4 NO	T 4	1 A 24 V DC 13	KT	
	color red RD, black BK, grey GR					
14	Drive with potentiometer PA9, actuating by rotary mechanism 1 wire-wound potentiometer T... 5 kOhm 2 Watt		KBAD 670		PA 9	
17	Drive with Hall sensors HA 11, actuating by rocker wheel installed with spring return in centre position, with electronic redundant Voltage output impressed Power supply 4,6-5,5 Volt output 0,5-2,5-4,5 Volt +5 mA output characteristic linear				HA 11	
18	Drive with potentiometer PA 12, actuating by rocker wheel installed with spring return in centre position, 1 conductive plastic potentiometer T 375 with centre tap 10 ⁷ switching cycles, resistance 2 x 5 kOhm 0,5 Watt wiper current max 1 mA, 2 direction contacts				PA 12	
19	Drive with Hall sensors HA 12, actuating by rocker wheel installed with spring return in centre position, with electronic redundant Voltage output impressed Power supply 4,6-5,5 Volt output 0,5-2,5-4,5 Volt +5 mA output characteristic linear				HA 12	
20	Drive with potentiometer PA 13, actuating by rotating palm grip left resp. right with spring return in centre position, 1 conductive plastic potentiometer T 375 with centre tap 10 ⁷ switching cycles, resistance 2x5 kOhm 0,5 Watt wiper current max 1 mA, 2 direction contacts				PA 13	
21	Drive with Hall sensors HA 13, actuating by rotating palm grip left resp. right with spring return in centre position, with electronic redundant Voltage output impressed Power supply 4,6-5,5 Volt output 0,5-2,5-4,5 Volt +5 mA output characteristic linear				HA 13	
22	Multi-axis controller V 21 look Catalog 1/146				V 21	
25	Vibrator button actuating through solenoid 24V DC impulse signal 100% duty cycle (e.g. indication of cable movement)				V	
30	Bellow for palm grip B 20 required for multi-axis controller V 8, VV 8, V 85, VV 85		KMD 109			
31	Bellow for palm grip B 20 and front plate with 4 screws M5 x 15 (for mounting the bellow) required for multi-axis controller V 6, VV 6		KMD 229 KBF 905			

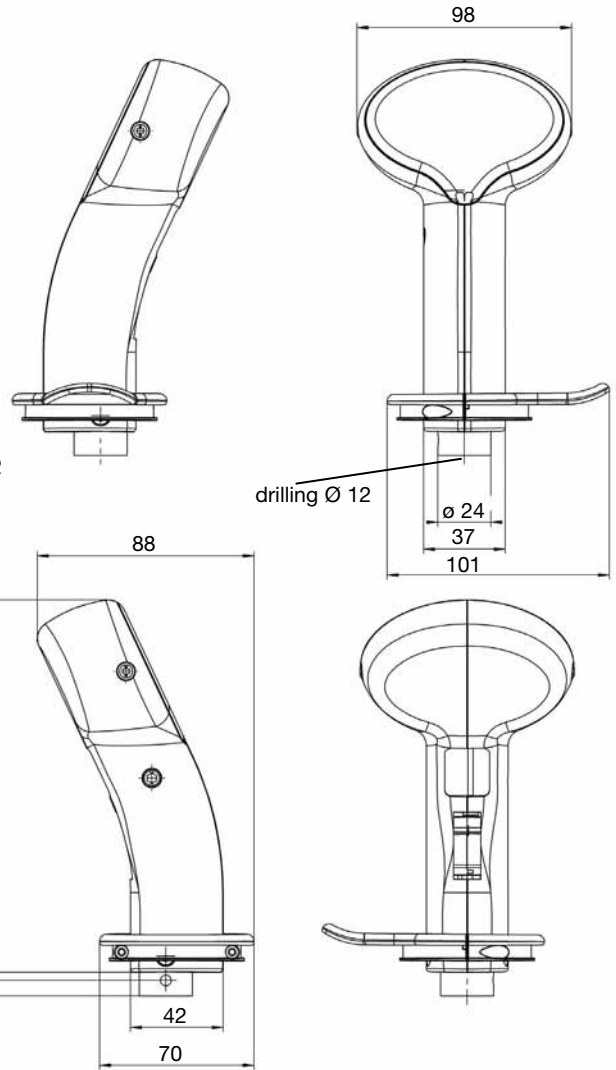
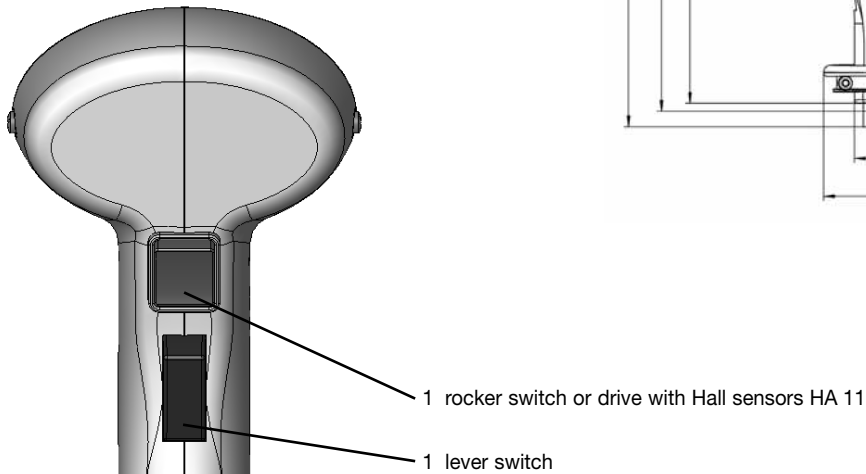
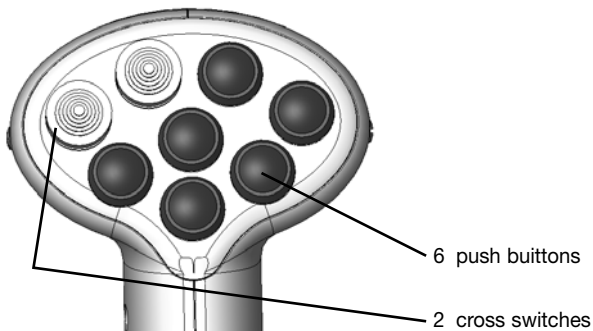
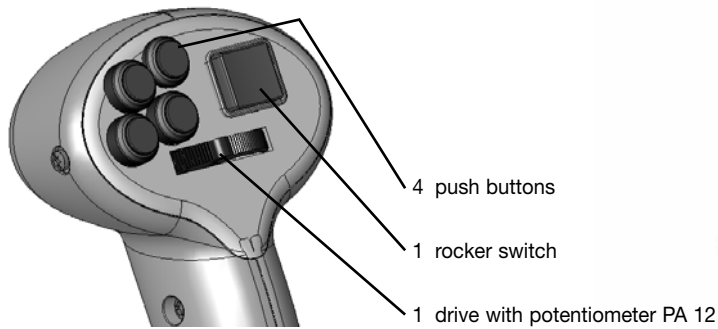
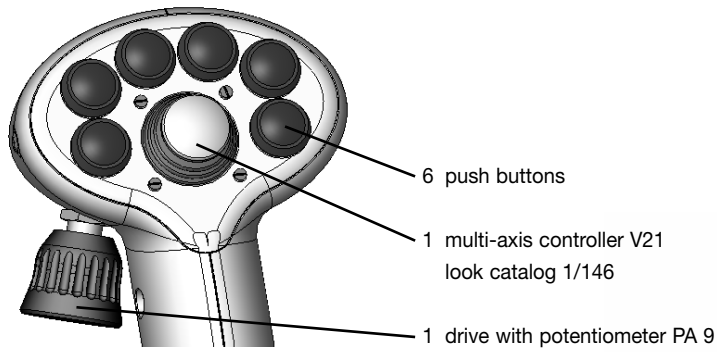

more variants available upon request

Example for type-sign

palm grip
push button
multi-axis controller V 21

B 20 6D V21 PA9 W K -X

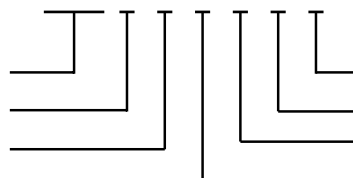

special please describe
lever switch
rocker switch
drive with potentiometer PA9



GESSMANN
Industrial controllers

Notice

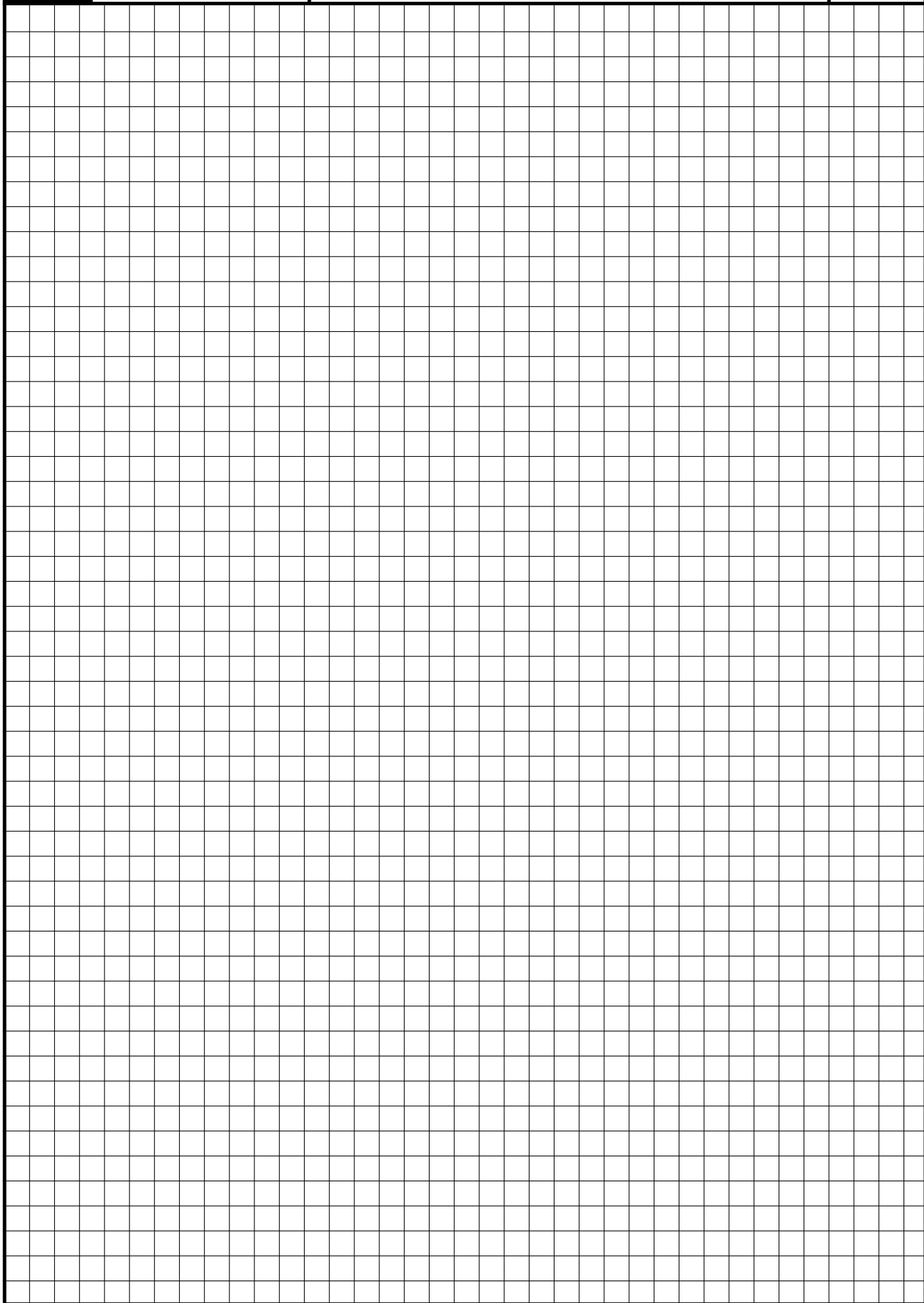



Pos.	Dimension outside in mm	Dimension inside in mm	Remarks	Weight kg	Type	Price EURO
Steel sheet housing material thickness 1/1,5 mm Protection IP 54 painting RAL 7032 pebble-grey textured varnish						
1	200 x 200 x 92	166 x 166 x 90		1,3	B 200	
2	230 x 230 x 105	196 x 196 x 102		1,4	B 230	
3	230 x 340 x 105	196 x 306 x 102		1,5	B 230 x 340	
4	230 x 440 x 105	196 x 406 x 102		1,6	B 230 x 440	
5	250 x 250 x 150	216 x 216 x 147		1,6	B 250 x 250	
6						
7	150 x 400 x 105	116 x 366 x 102		3,2	B 150 x 400	
8	150 x 500 x 105	116 x 466 x 102		3,5	B 150 x 500	
9	150 x 600 x 105	116 x 566 x 102		3,8	B 150 x 600	
10	260 x 500 x 105	226 x 466 x 102		3,8	B 260 x 500	
11	260 x 600 x 105	226 x 566 x 102		4,2	B 260 x 600	
12	Dimensions special		on enquiry			
Plastic housing polycarbonat Protection IP 65 colour RAL 7035 fair-grey						
13	120 x 122 x 105	113 x 115 x 98		0,35	I 120 x 122	
14	120 x 160 x 140	113 x 134 x 133		0,6	I 120 x 160	
15	160 x 240 x 120	153 x 215 x 114		0,8	I 160 x 240	
16	160 x 360 x 100	153 x 352 x 94		1,0	I 160 x 360	
17	230 x 300 x 110	223 x 293 x 103		1,15	I 230 x 300	
18						
19						
20						
21						
22						
Plastic housing polyester Protection IP 65 colour RAL 7000 grey						
23	220 x 335 x 115	200 x 292 x 108	colour alternative RAL 9011 black	1,65	I 220 x 335	
24	220 x 465 x 115	200 x 432 x 108	colour alternative RAL 9011 black	2,24	I 220 x 465	
25	250 x 255 x 120	236 x 243 x 110		2,65	I 250 x 255	
26	250 x 400 x 120	236 x 386 x 110		3,65	I 250 x 400	
27	250 x 600 x 120	236 x 586 x 110		5,24	I 250 x 600	
28						
29						
30						
31						
32						
Accessory parts						
33	Hinges each housing (2 pcs.)			0,2		
34	Armrest with clamp adjustable straps			0,5		
35	Chest panel and straps			0,6		
36	Base bracket each housing (2 pcs.)			0,3		
37	Filter plug M 20		for air-condition	0,15		
38	Cable entry M 20 cable 7-13 mm		with anti-kink protection and strain relief	0,15		
39	Cable entry M 32 cable 11-21 mm		with anti-kink protection and strain relief	0,2		
40	Cable entry M 40 cable 19-28 mm		with anti-kink protection and strain relief	0,25		
41	Pillar with flange 100 x 100 x 535 mm high		flange 150 x 150 mm	14,0		
42	Indicating labels not engraved					
43	Engraving, each 10 characters					
44						
45						



Manufacture Siemens 3 SB 22 mm

Pos.	Command devices			Weight gramm	Type	Price EURO
1	Push button		1 NO + 1 NC	40	D	
2	Selector switch 0-1	2 positions	1 NO + 1 NC	50	W	
3	Selector switch 1-0-2	3 positions	2 NO + 2 NC	60	W	
4						
5						
6	Key switch 0-1	2 positions	1 NO + 1 NC	130	S	
7	Key switch 1-0-2	3 positions	2 NO + 2 NC	140	S	
8						
9						
10	Mushroom key switch latching		1 NO + 1 NC	80	PS	
11	Mushroom head push button latching		1 NC	60	PV	
12						
13						
14						
15	Contact block additional (max. 3 pcs.)		1 NO + 1 NC	10		
	Command and indicating devices					
16	Illuminated push button lamp 24 V AC		1 NO + 1 NC	40	LD	
17	Illuminated push button lamp 110 V operating voltage 220 V AC		1 NO + 1 NC	40	LD	
18	Illuminated push button lamp 24 V with transformer 220/24 V AC		1 NO + 1 NC	50	LD	
19						
20	Contact block additional (max. 3 pcs.)		1 NO + 1 NC	10		
	Indicating devices					
21	Indicator light lamp 24 V AC			40	L	
22	Indicator light lamp 110 V operating voltage 220 V AC			40	L	
23	Indicator light lamp 24 V with transformer 220/24 V AC			50	L	
24						
25						
	Special devices					
26	Drilling diameter 22 mm					
27	Blind plug 22					
28						
29	Push button with 2 steps SES 2		2 NO + 1 NC	300		
30	Push button with 2 steps ST 1-3-2		2 NO + 1 NC	300		
31	Push button with 3 steps ST 1-4-3		3 NO + 1 NC	350		
32	Push button with 4 steps ST 1-5-4		4 NO + 1 NC	400		
33	Push button with potentiometer PT 1-2-P		1 NO + 1 NC	350		
34	Wire-wound potentiometer T 237 linear Life 10 ⁶ switching cycles					
35	resistance 0,5/1,0/2,0/5,0 kOhm 1 Watt wiper current max. 10 mA					
36	Drive for potentiometer M4168 with friction brake, switching sequence -0-, contact (potentiometer look 1/240)			250		
37	Summer EKS 24 V DC / 48 V AC / 220 V AC			250		
38	Knee button FAK-S/KC/I		1 NO + 1 NC	350		
39	Foot button 3SE 3902-OAB20		1 NO + 1 NC	450		
40						

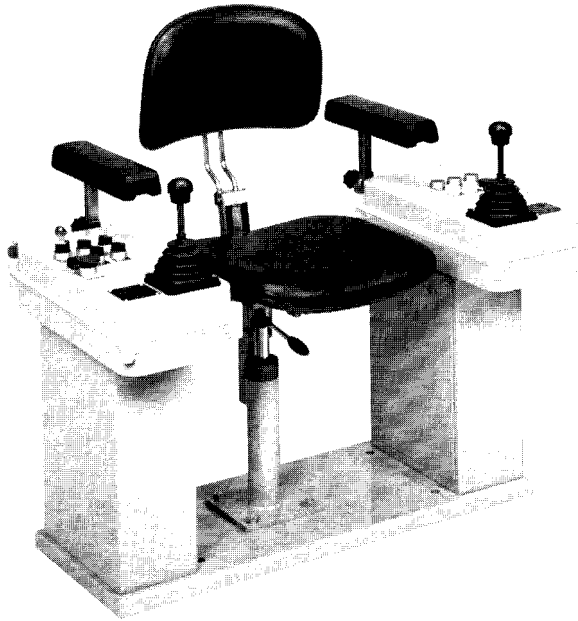

Type KST3KFS2-...

The crane control unit KST 3 combines in its design the crane driver's seat and the control and monitoring devices. Ready wired, it can be easily and quickly installed in the crane cabin.

Equipment boxes: Plastic polyester.

The equipment boxes with the devices fitted have hinged tops that can be locked in position. They contain the termination and connection facilities and a lockable plug-in cover on the inside.

Seat KFS 2: The seat backrest can be tipped forwards and further tipped together with the cushion.

The cushion and seat backrest are padded.

Adjusting possibilities: Cushion horizontally and vertically.

Height adjustment via a gas-loaded spring in the seat base.

Seat backrest horizontally and vertically to the cushion.

Armrests padded and adjustable in height.

Fixed to the equipment boxes.

Surface treatment: Anti-corrosion primer, top coat: 2 coats of epoxy-resin paint, standard colour RAL 7032 pebble-grey, textured Varnish

All non-painted metal parts are electrogalvanized and chromed.

Description data see catalog 5/003/004

Permissible ambient temperature	Operation -40° C to +60° C Storage -50° C to +80° C
Climate resistance	
Damp heat constant	DIN IEC 68 part 2-3
Damp heat cyclic	DIN IEC 68 part 2-30
Degree of protection	IP 54 IEC 529 DIN 40050

Pos.				Weight kp	Type	Price EURO
1	Crane control unit with driver's seat	KFS 2	with base plate	36	KST 3	
2	Crane control unit with driver's seat	KFS 2	without base plate	31	KST 31	
3	Crane control unit without driver's seat	KFS 2	with base plate	21	KST 32	
4	Crane control unit without driver's seat	KFS 2	without base plate	16	KST 33	
5						
10	Driver's seat	see catalog 2/130 (picture shows)			KFS 2	
11						
12	Driver's seat	see catalog 2/132			KFS 4	
13						
14						
15	Driver's seat	see catalog 2/140			KFS 9	
20	Multi-axis controller	see catalog 1/100				
21	Single-axis controller	see catalog 1/200				
22						
23	Control-switch	see catalog 1/220				
24	Command and indicating devices	see catalog 1/360				
25						
30	Terminal block 4 mm ² without wiring each terminal				KL	
31	Terminal block 4 mm ² with wiring wire 1,5 mm ² each terminal				KL	
32	External wiring single wire highly flexible 1,5 mm ² 5 metre long					
33	Additional or subtract price each metre					
34						
35						
40	Special painted					
41	Indicating labels not engraved with 2 or 4 arrows					
42	Engraving, each 10 characters					
43						

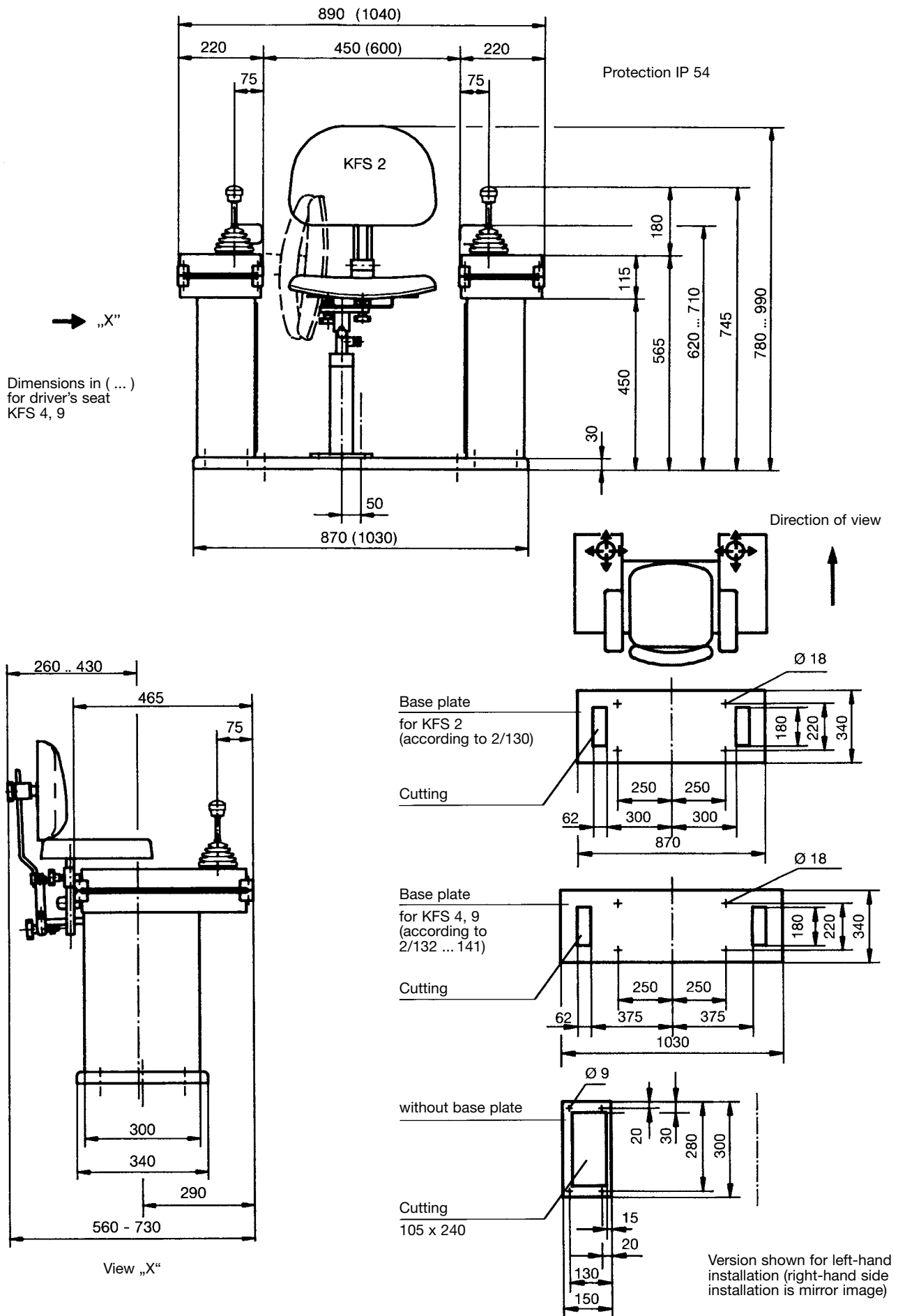



Type KST41KFS92-...

The swivelling crane control unit KST 4 is ergonomically designed and provides a high degree of comfort.

The standard design includes following:

Equipment boxes: Sheet steel.

The equipment boxes with the devices can be vertically and horizontally adjusted together with the armrests. Cabling is run through duct in the cross-member. (Terminal block).

Seat: Comfortable spring mounted seat KFS 6, with an oilhydraulic vibration absorption system, weight adjustment and air-permeable artificial leather or textil material, with headrest.

Adjusting possibilities: Seat horizontally and vertically. Inclination of cushion, backrest and armrest also adjustable. Weight setting for optimum spring suspension, right equipment box turnable.

Cross-member: Steel selection, top of which can be raised to lay cabling. The seat can be tilted backwards so that the cable duct in the cross-member is accessible.

Swivel base: Zero-end-float spring-loaded bearing. Rotational movement 180° right, 90° left, stopped by friction brake.

Surface treatment: Anti-corrosion primer, top coat: 2 coats of epoxy-resin paint, standard colour RAL 9011 black. textured varnish

All non-painted metal parts are electrogalvanized and chromed.

Permissible ambient temperature	Operation -40° C to +60° C
	Storage -50° C to +80° C
Climate resistance	
Damp heat constant	DIN IEC 68 part 2-3
Damp heat cyclic	DIN IEC 68 part 2-30
Degree of protection	IP 54 IEC 529 DIN 40050

Description data see catalog 5/003/004

Pos.				Weight kp	Type	Price EURO
1	Crane control unit standard design	Equipment boxes 160 x 420 mm		58	KST 41	
2	Crane control unit standard design	Equipment boxes 200 x 420 mm		60	KST 42	
3						
4						
5	Crane control unit standard design	Equipment boxes special dimensions			KST 4x	
6	additional variations for driver's seat KFS 6 see catalog 2/134				KFS 6	
7	Driver's seat KFS 9	see catalog 2/140			KFS 9	
8						
9						
10	Footrest mounted onto swivel base adjustable ± 30 mm			8		
11						
12	Plate for horizontal manual adjustment of control unit adjustable ± 250 mm					
13						
14						
15						
16						
17						
18						
19	Heating 2 x 2 kW with ventilator 230 V 50 Hz airvolume ca. 300 m³/h mounted on the swivel base sidewise					
20	Multi-axis controller	see catalog 1/100				
21	Single-axis controller	see catalog 1/200				
22	Double-handle controller	see catalog 1/160				
23	Control-switch	see catalog 1/220				
24	Command and indicating devices	see catalog 1/360				
30	Terminal block 4 mm² without wiring each terminal				KL	
31	Terminal block 4 mm² with wiring wire 1,5 mm² each terminal				KL	
32	External wiring single wire highly flexible 1,5 mm² 5 metre long					
33	Additional or subtract price each metre					
40	Special painted					
41	Indicating labels not engraved with 2 or 4 arrows					
42	Engraving, each 10 characters					

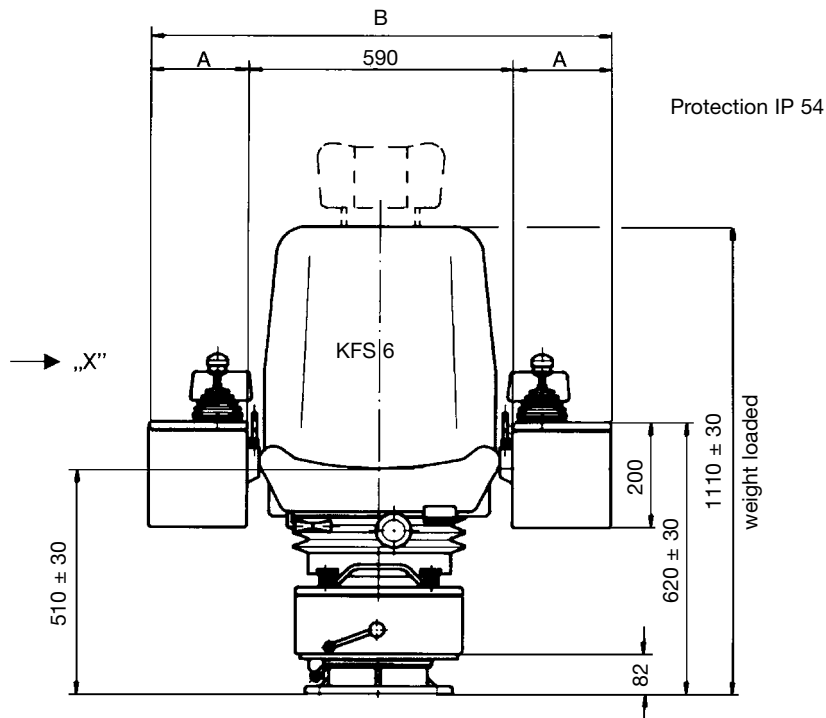

Type	Dimension A	Dimension B	Dimension C
KST 41	160	910	<625 >700
KST 42	200	990	<655 >730

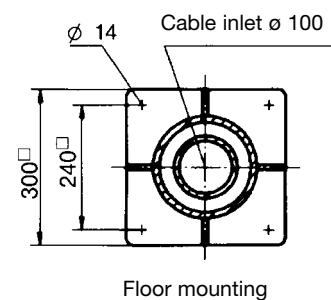
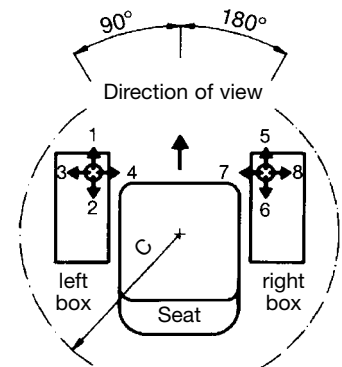
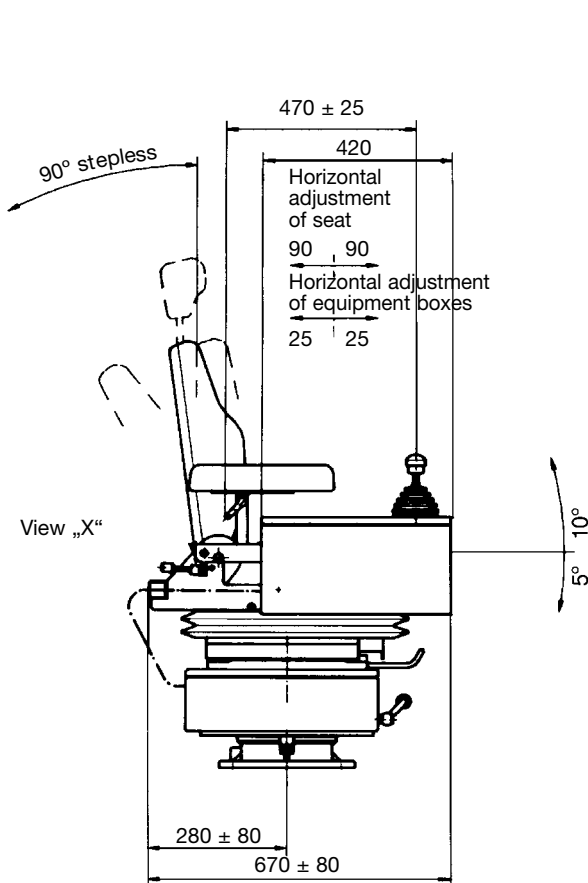



Type KST51KFS92-...

The swivelling crane control unit KST 5 is ergonomically designed and provides a high degree of comfort.

The standard design includes following:

Equipment boxes: Sheet steel. The top panel of the equipment boxes with the devices can be raised and locked in position. The terminal strip is easily accessible via an opening on the inside that can be closed with a lockable cover.

Seat: Comfortable spring mounted seat KFS 6, with an oilhydraulic vibration absorption system, weight adjustment and air-permeable artificial leather or textil material, with headrest, with armrests.

Adjusting possibilities: Seat horizontally and vertically. Inclination of cushion, backrest and armrest also adjustable. Weight setting for optimum spring suspension.

Cross-member: Steel section, top of which can be raised to lay cabling. The seat can be tilted backwards so that the cable duct in the cross-member is accessible.

Swivel base: Zero-end-float spring-loaded bearing. Rotational movement 180° right, 90° left, stopped by friction brake.

Surface treatment: Anti-corrosion primer, top coat: 2 coats of epoxy-resin paint, standard colour RAL 7032 pebble-grey. textured varnish
All non-painted metal parts are electrogalvanized and chromed.

Permissible ambient temperature	Operation -40° C to +60° C Storage -50° C to +80° C
Climate resistance	
Damp heat constant	DIN IEC 68 part 2-3
Damp heat cyclic	DIN IEC 68 part 2-30
Degree of protection	IP 54 IEC 529 DIN 40050

Description data see catalog 5/003/004

Pos.				Weight kp	Type	Price EURO
1	Crane control unit standard design	Equipment boxes 200 x 580 mm		84	KST 51	
2	Crane control unit standard design	Equipment boxes 270 x 580 mm		88	KST 52	
3						
4	Crane control unit standard design	Equipment boxes 320 x 580 mm		92	KST 54	
5	Crane control unit standard design	Equipment boxes special dimensions			KST 5x	
6	additional variations for driver's seat KFS 6 see catalog 2/134				KFS 6	
7	Driver's seat KFS 9	see catalog 2/140			KFS 9	
8	Driver's seat KFS 10	see catalog 2/142			KFS 10	
9	Monitor mounting support left or right T 478			10		
10	Footrest mounted onto swivel base adjustable ± 30 mm			8		
11						
12	Manual adjustment of equipment boxes horizontal adjustable ± 75 mm					
13	Plate for horizontal manual adjustment of control unit adjustable ± 250 mm			95		
14	Manual adjustment of control unit vertical (gas loaded spring) adjustable 80 mm			25		
15						
16						
17						
18	Motorized adjustment of control unit swivelling (drive 24 V DC seat height + 30 mm)			8		
19	Heating 2 x 2 kW with ventilator 230 V 50 Hz airvolume ca. 300 m³/h mounted on the swivel base sidewise					
20	Multi-axis controller	see catalog 1/100				
21	Single-axis controller	see catalog 1/200				
22	Double-handle controller	see catalog 1/160				
23	Control-switch	see catalog 1/220				
24	Command and indicating devices	see catalog 1/360				
30	Terminal block 4 mm² without wiring each terminal				KL	
31	Terminal block 4 mm² with wiring wire 1,5 mm² each terminal				KL	
32	External wiring single wire highly flexible 1,5 mm² 5 metre long					
33	Additional or subtract price each metre					
40	Special painted					
41	Indicating labels not engraved with 2 or 4 arrows					
42	Engraving, each 10 characters					

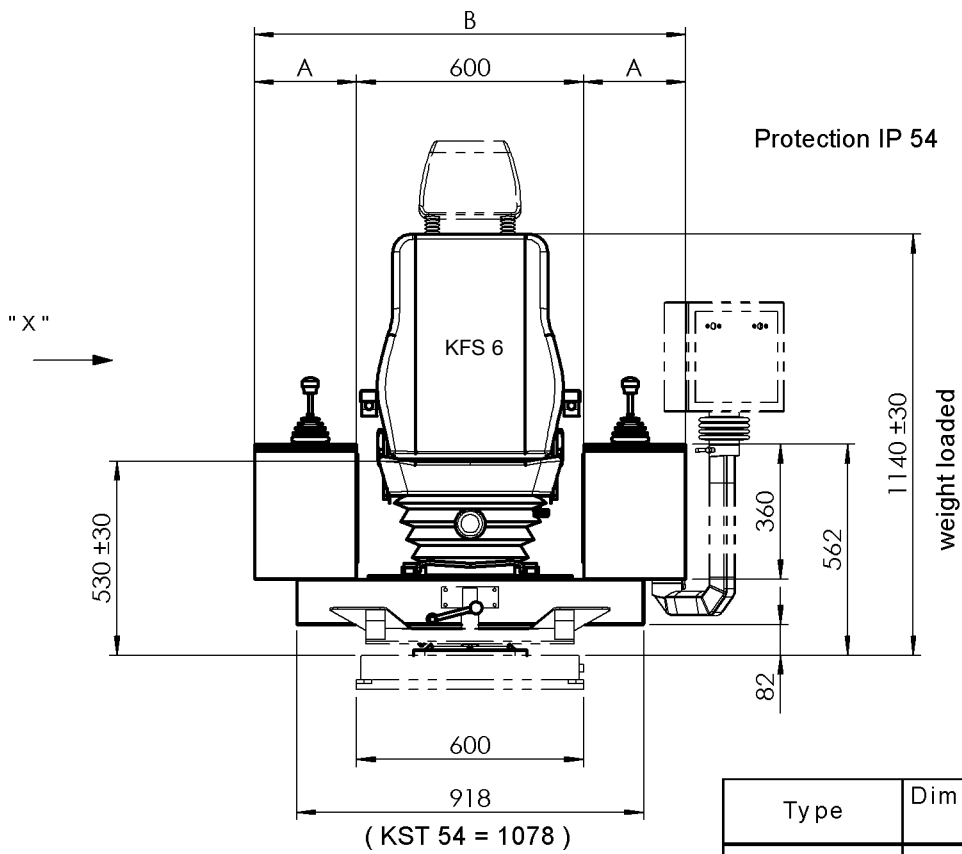

Type	Dimension A	Dimension B	Dimension C
KST 51	200	1000	580
KST 52	270	1140	640
KST 54	320	1240	690

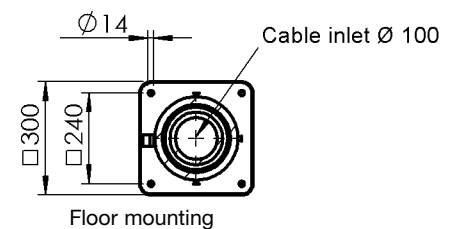
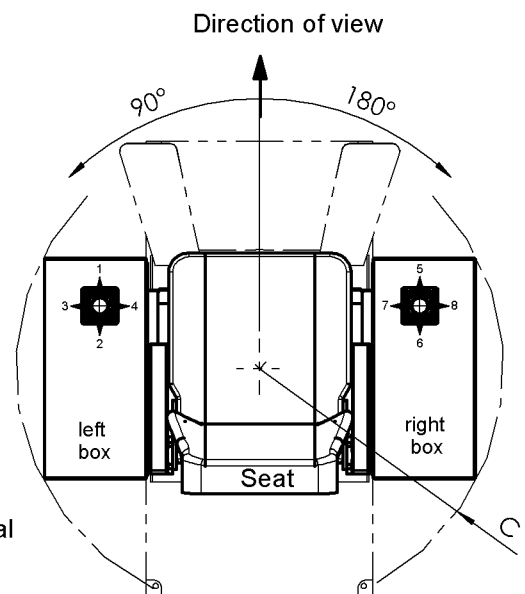
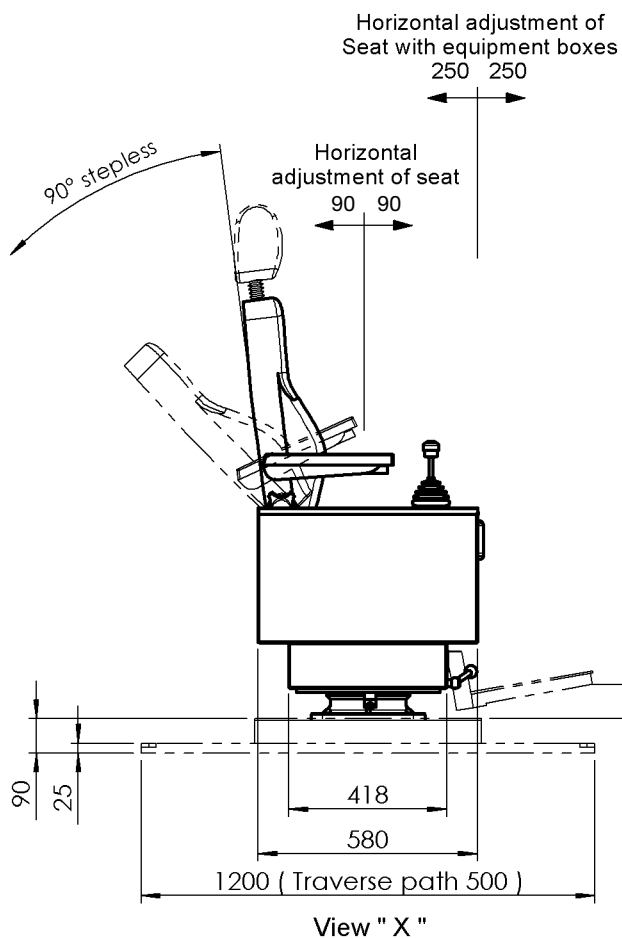



Type KST6KFS92-...

The swivelling crane control unit KST 6 is ergonomically designed and provides a high degree of comfort.

The standard design includes following:

Equipment boxes: plastic PU foam

The equipment boxes with the devices can be vertically and horizontally adjusted together with the armrests. Cabling is run through duct in the cross-member. (Terminal block).

Seat: Comfortable spring mounted seat KFS 6, with an oilhydraulic vibration absorption system, weight adjustment and air-permeable artificial leather or textil material, with headrest, with armrests.

Adjusting possibilities: Seat horizontally and vertically. Inclination of cushion, backrest and armrest also adjustable. Weight setting for optimum spring suspension.

Cross-member: Steel section, top of which can be raised to lay cabling. The seat can be tilted backwards so that the cable duct in the cross-member is accessible.

Swivel base: Zero-end-float spring-loaded bearing. Rotational movement 180° right, 90° left, stopped by friction brake.

Surface treatment: Anti-corrosion primer, top coat: 2 coats of epoxy-resin paint, standard colour RAL 9011 black. textured varnish

All non-painted metal parts are electrogalvanized and chromed.

Permissible ambient temperature	Operation -40° C to +60° C
	Storage -50° C to +80° C
Climate resistance	
Damp heat constant	DIN IEC 68 part 2-3
Damp heat cyclic	DIN IEC 68 part 2-30
Degree of protection	IP 54 IEC 529 DIN 40050

Description data see catalog 5/003/004

Pos.				Weight kp	Type	Price EURO
1	Crane control unit standard design			48	KST 6	
2	Crane control unit standard design	not swivelled		48	KST 61	
3	Crane control unit standard design	without swivel base and cross-member		38	KST 62	
4						
5						
6	additional variations for driver's seat KFS 6	see catalog 2/134			KFS 6	
7	Driver's seat KFS 9	see catalog 2/140			KFS 9	
8						
9						
10	Footrest mounted onto swivel base adjustable	± 30 mm		8		
11						
12						
13	Plate for horizontal manual adjustment of control unit	adjustable ± 250 mm		95		
14						
15						
16						
17						
18						
19	Heating 2 x 2 kW with ventilator 230 V 50 Hz	airvolume ca. 300 m³/h mounted on the swivel base sidewise				
20	Multi-axis controller	see catalog 1/100				
21	Single-axis controller	see catalog 1/200				
22	Double-handle controller	see catalog 1/160				
23	Control-switch	see catalog 1/220				
24	Command and indicating devices	see catalog 1/360				
30	Terminal block 4 mm² without wiring	each terminal			KL	
31	Terminal block 4 mm² with wiring wire 1,5 mm²	each terminal			KL	
32	External wiring single wire highly flexible 1,5 mm²	5 metre long				
33	Additional or subtract price	each metre				
40	Special painted					
41	Indicating labels not engraved with 2 or 4 arrows					
42	Engraving, each 10 characters					

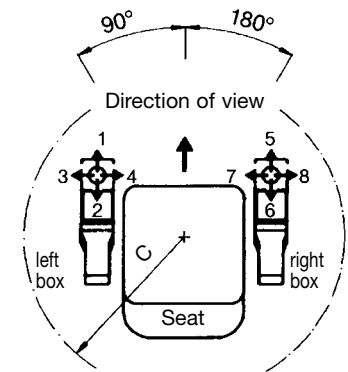
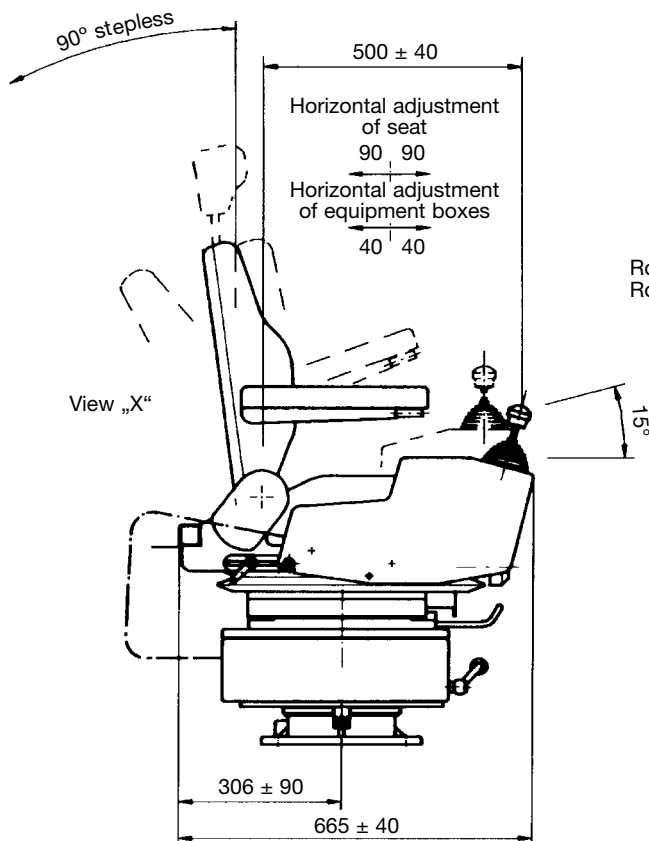
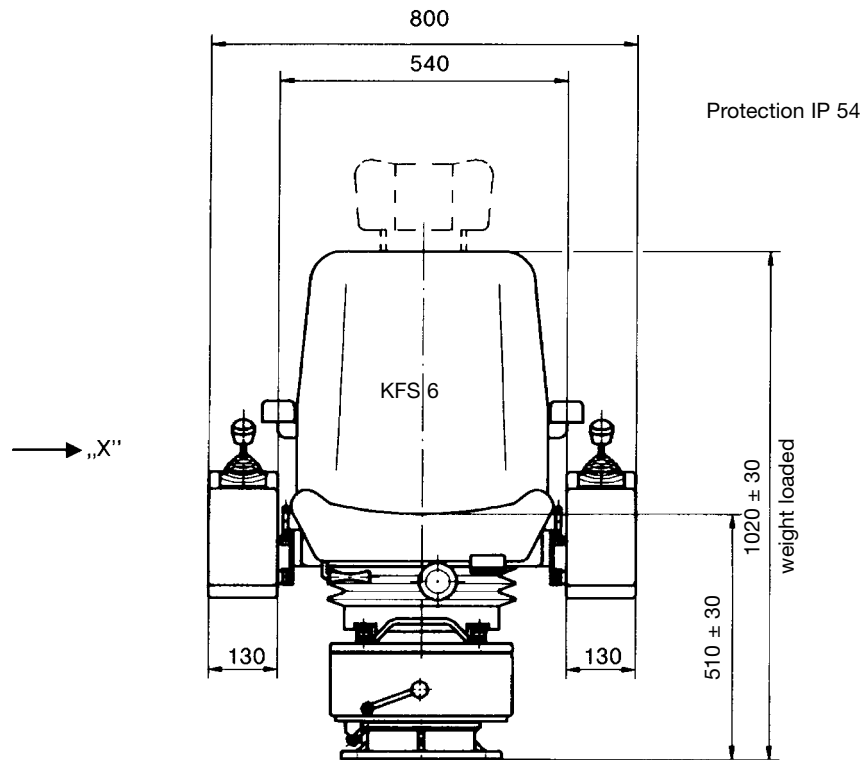

Rotation radius ,C' - bei minimal adjusting = 520 mm
Rotation radius ,C' - bei maximal adjusting = 620 mm

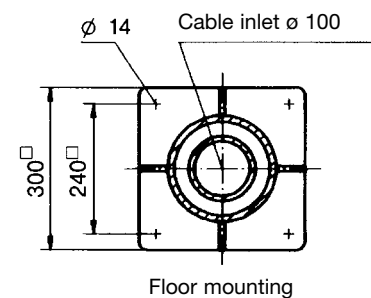

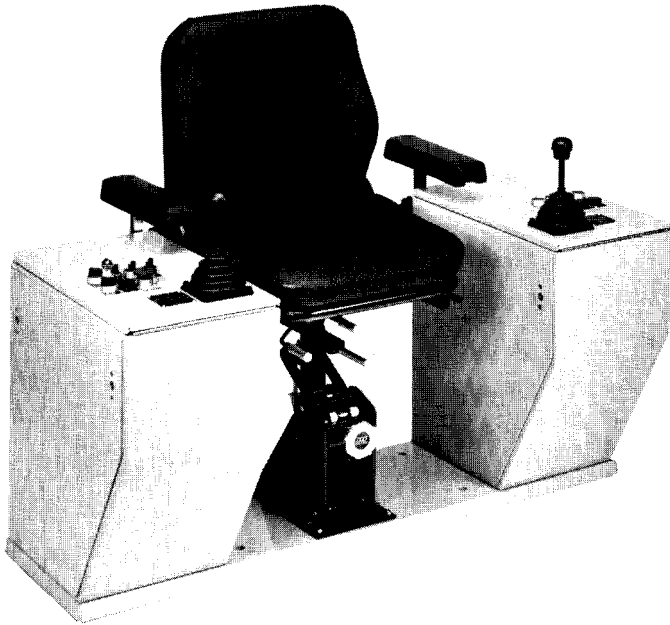

Type KST72KFS4-...

The crane control unit KST 7 combines in its design the crane driver's seat and the control and monitoring devices. Ready wired, it can be easily and quickly installed in the crane cabin.

Equipment boxes: Sheet steel.

The equipment boxes with the devices fitted have hinged tops that can be locked in position. They contain the termination and connection facilities and a lockable plug-in cover on the inside.

Seat KFS 2: The seat backrest can be tipped forwards and further tipped together with the cushion.

The cushion and seat backrest are padded.

Adjusting possibilities: Cushion horizontally and vertically.

Height adjustment via a gas-loaded spring in the seat base.

Seat backrest horizontally and vertically to the cushion.

Armrests padded and adjustable in height.

Fixed to the equipment boxes.

Surface treatment: Anti-corrosion primer, top coat: 2 coats of epoxy-resin paint, standard colour RAL 7032 pebble-grey, textured varnish

All non-painted metal parts are electrogalvanized and chromed.

Description data see catalog 5/003/004

Permissible ambient temperature	Operation -40° C to +60° C
	Storage -50° C to +80° C
Climate resistance	
Damp heat constant	DIN IEC 68 part 2-3
Damp heat cyclic	DIN IEC 68 part 2-30
Degree of protection	IP 54 IEC 529 DIN 40050

Pos.					Weight kp	Type	Price EURO
1	Crane control unit with driver's seat	KFS 2	with base plate		51	KST 7	
2	Crane control unit with driver's seat	KFS 2	without base plate		46	KST 71	
3	Crane control unit without driver's seat	KFS 2	with base plate		36	KST 72	
4	Crane control unit without driver's seat	KFS 2	without base plate		31	KST 73	
5							
10	Driver's seat	see catalog 2/130				KFS 2	
11							
12	Driver's seat	see catalog 2/132 (picture shows)				KFS 4	
13							
14							
15	Driver's seat	see catalog 2/140				KFS 9	
20	Multi-axis controller	see catalog 1/100					
21	Single-axis controller	see catalog 1/200					
22	Double-handle controller	see catalog 1/160					
23	Control-switch	see catalog 1/220					
24	Command and indicating devices	see catalog 1/360					
25							
30	Terminal block 4 mm ² without wiring each terminal					KL	
31	Terminal block 4 mm ² with wiring wire 1,5 mm ² each terminal					KL	
32	External wiring single wire highly flexible 1,5 mm ² x 5 metre long						
33	Additional or subtract price each metre						
34							
35							
40	Special painted						
41	Indicating labels not engraved with 2 or 4 arrows						
42	Engraving, each 10 characters						
43							

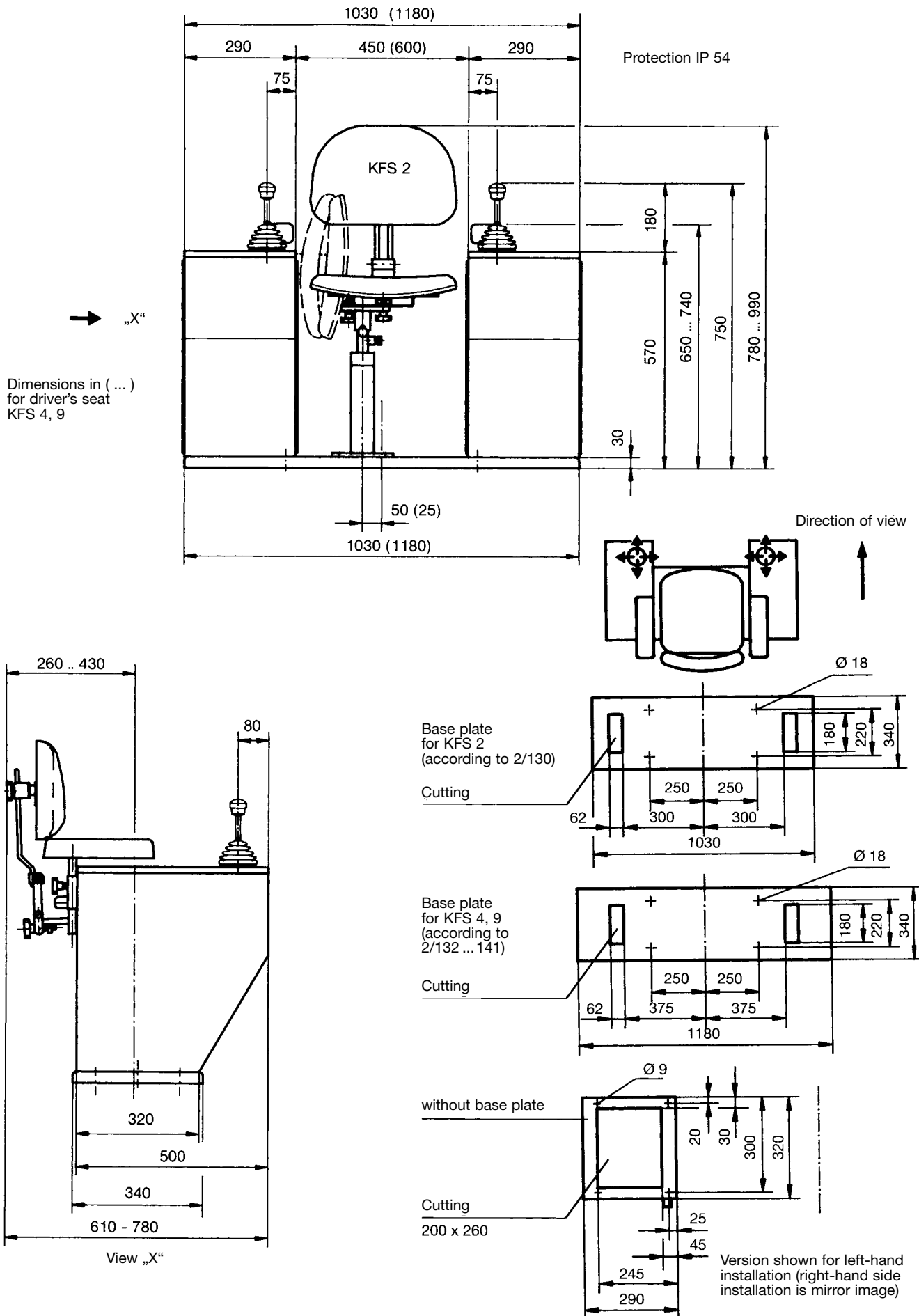



Type KST75KFS2-...

The crane control unit KST 75 combines in its design the crane driver's seat and the control and monitoring devices. Ready wired, it can be easily and quickly installed in the crane cabin.

Equipment boxes: Sheet steel.

The equipment boxes with the devices fitted have hinged tops that can be locked in position.

They contain the termination and connection facilities and a lockable plug-in cover on the inside.

Seat KFS 2: The seat backrest can be tipped forwards and further tipped together with the cushion.

The cushion and seat backrest are padded.

Adjusting possibilities: Cushion horizontally and vertically.

Height adjustment via a gas-loaded spring in the seat base.

Seat backrest horizontally and vertically to the cushion.

Armrests padded and adjustable in height.

Fixed to the equipment boxes.

Surface treatment: Anti-corrosion primer, top coat: 2 coats of epoxy-resin paint, standard colour RAL 7032 pebble-grey, textured varnish

All non-painted metal parts are electrogalvanized and chromed.

Description data see catalog 5/003/004

Permissible ambient temperature	Operation -40° C to +60° C Storage -50° C to +80° C
Climate resistance	
Damp heat constant	DIN IEC 68 part 2-3
Damp heat cyclic	DIN IEC 68 part 2-30
Degree of protection	IP 54 IEC 529 DIN 40050

Pos.					Weight kp	Type	Price EURO
1	Crane control unit with driver's seat	KFS 2	with base plate		51	KST 75	
2	Crane control unit with driver's seat	KFS 2	without base plate		46	KST 76	
3	Crane control unit without driver's seat	KFS 2	with base plate		36	KST 77	
4	Crane control unit without driver's seat	KFS 2	without base plate		31	KST 78	
5							
10	Driver's seat	see catalog 2/130 (picture shows)				KFS 2	
11							
12	Driver's seat	see catalog 2/132				KFS 4	
13							
14							
15	Driver's seat	see catalog 2/140				KFS 9	
20	Multi-axis controller	see catalog 1/100					
21	Single-axis controller	see catalog 1/200					
22	Double-handle	see catalog 1/160					
23	Control-switch	see catalog 1/220					
24	Command and indicating devices	see catalog 1/360					
25							
30	Terminal block 4 mm ² without wiring each terminal					KL	
31	Terminal block 4 mm ² with wiring wire 1,5 mm ² each terminal					KL	
32	External wiring single wire highly flexible 1,5 mm ² x 5 metre long						
33	Additional or subtract price each metre						
34							
35							
40	Special painted						
41	Indicating labels not engraved with 2 or 4 arrows						
42	Engraving, each 10 characters						
43							

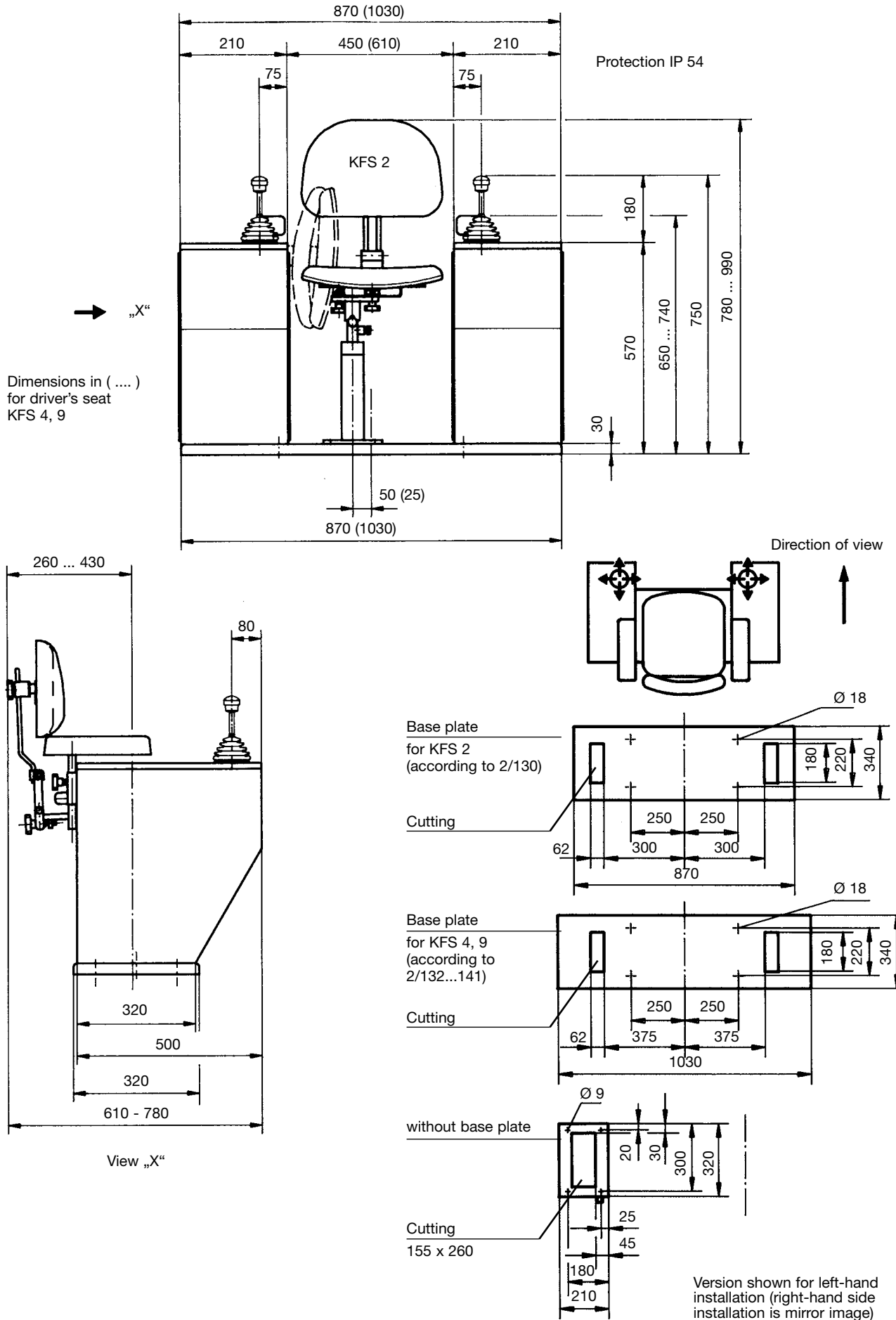



Type KST8KFS62-...

The swivelling crane control unit KST 8 is ergonomically designed and provides a high degree of comfort.

The standard design includes following:

Equipment boxes: plastic PU foam

The equipment boxes with the devices can be vertically and horizontally adjusted together with the armrests. Cabling is run through duct in the cross-member. (Terminal block).

Seat: Comfortable spring mounted seat KFS 6, with an oilhydraulic vibration absorption system, weight adjustment and air-permeable artificial leather or textil material.

Adjusting possibilities: Seat horizontally and vertically. Inclination of cushion, backrest and armrest also adjustable. Weight setting for optimum spring suspension. Right equipment box turnable.

Cross-member: Steel section, top of which can be raised to lay cabling. The seat can be tilted backwards so that the cable duct in the cross-member is accessible.

Swivel base: Zero-end-float spring-loaded bearing. Rotational movement 180° right, 90° left, stopped by friction brake.

Surface treatment: Anti-corrosion primer, top coat: 2 coats of epoxy-resin paint, standard colour RAL 9011 black. textured varnish

All non-painted metal parts are electrogalvanized and chromed.

Permissible ambient temperature	Operation -40° C to +60° C
	Storage -50° C to +80° C
Climate resistance	
Damp heat constant	DIN IEC 68 part 2-3
Damp heat cyclic	DIN IEC 68 part 2-30
Degree of protection	IP 54 IEC 529 DIN 40050

Description data see catalog 5/005

Pos.				Weight kp	Type	Price EURO
1	Crane control unit standard design			48	KST 8	
2	Crane control unit standard design not swivelled			48	KST 81	
3	Crane control unit standard design without swivel base and cross-member			38	KST 82	
4						
5						
6	additional variations for driver's seat KFS 6 see catalog 2/134				KFS 6	
7	Driver's seat KFS 9 see catalog 2/140				KFS 9	
8						
9						
10	Footrest mounted onto swivel base adjustable ± 30 mm			8		
11						
12						
13	Plate for horizontal manual adjustment of control unit adjustable ± 250 mm			95		
14						
15						
16						
17						
18						
19	Heating 2 x 2 kW with ventilator 230 V 50 Hz airvolume ca. 300 m³/h mounted on the swivel base sidewise					
20	Multi-axis controller see catalog 1/100					
21	Single-axis controller see catalog 1/200					
22	Double-handle controller see catalog 1/160					
23	Control-switch see catalog 1/220					
24	Command and indicating devices see catalog 1/360					
30	Terminal block 4 mm² without wiring each terminal				KL	
31	Terminal block 4 mm² with wiring wire 1,5 mm² each terminal				KL	
32	External wiring single wire highly flexible 1,5 mm² 5 metre long					
33	Additional or subtract price each metre					
40	Special painted					
41	Indicating labels not engraved with 2 or 4 arrows					
42	Engraving, each 10 characters					

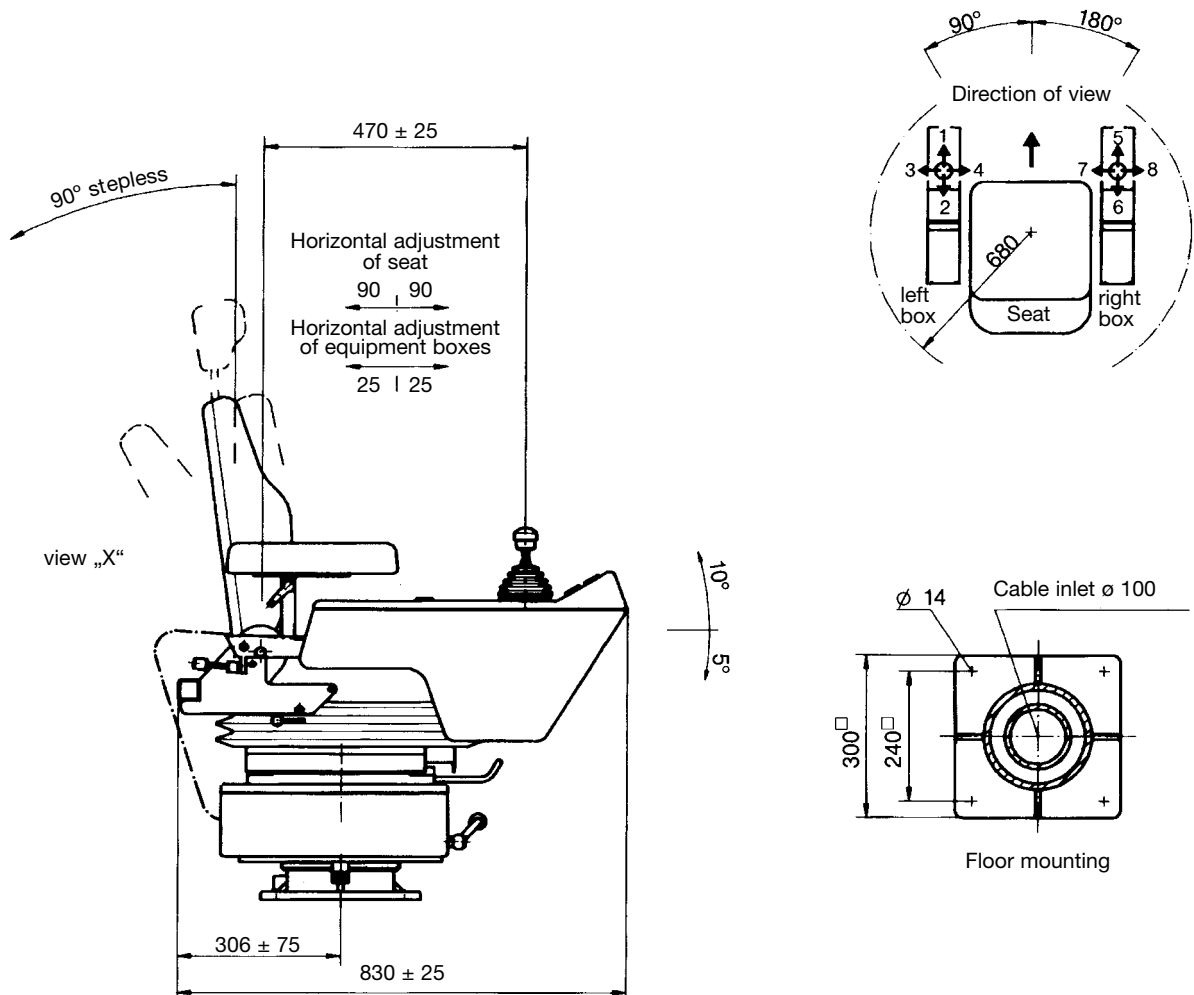
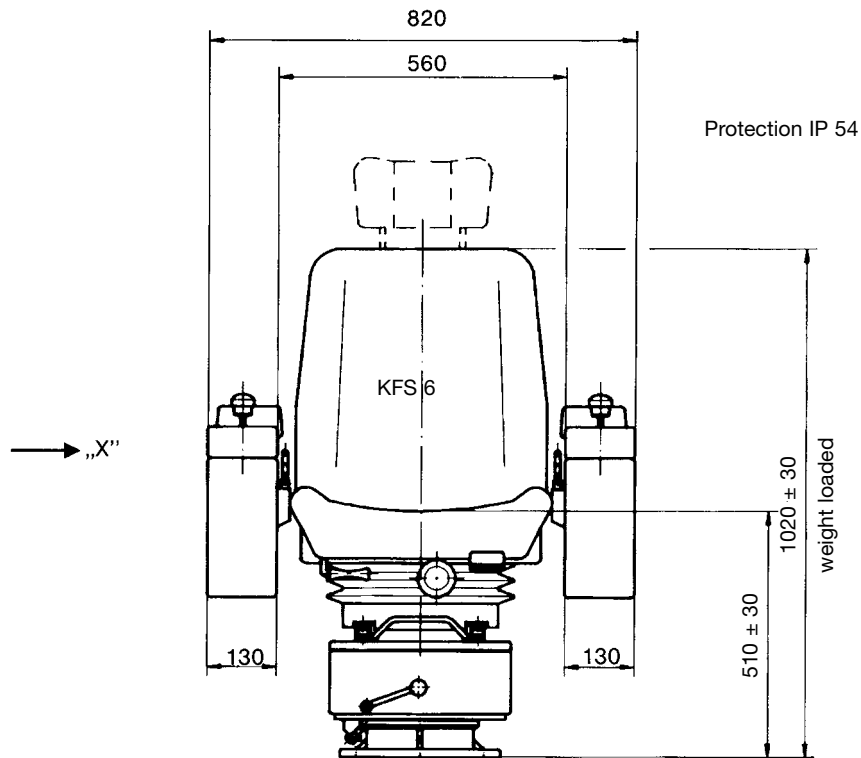



Type KST85KFS8-...

The crane control unit KST 85 is ergonomically designed and provides a high degree of comfort.

The standard design includes following.

Equipment boxes: plastic PU foam

The equipment boxes with the devices can be vertically and horizontally adjusted together with the armrest. Cabling is run through duct on the terminal block. (The terminal block housing is mounting behind the seat)

Seat: Comfortable static mounted seat KFS 8, covered with air-permeable artificial leather or with textil material and with roller-bearing swivel system, with headrest.

Adjusting possibilities: Seat horizontally and vertically. Inclination of cushion, backrest and armrest also adjustable. Seat with the equipment boxes swivelled 90° one sided. Endpoints to look. Right equipment box turnable.

Console: Heating 2 steps 2 x 2 kW 380 V AC
Ventilator 380 V AC air volume ca 1000 m³/h air circulation (opening in the rear side of the console) fresh air circulation (opening in the underside of the console). Selector switch for heating/ventilator are in the box. The seat can be tilted forward to reach the terminal block of the heating / ventilator.

Surface treatment: Anti-corrosion primer, top coat: 2 coats of epoxy-resin paint, standard colour RAL 9011 black. textured varnish

All non-painted metal parts are electrogalvanized and chromed.

Permissible ambient temperature	Operation -40° C to +60° C
	Storage -50° C to +80° C
Climate resistance	
Damp heat constant	DIN IEC 68 part 2-3
Damp heat cyclic	DIN IEC 68 part 2-30
Degree of protection	IP 54 IEC 529 DIN 40050

Description data see catalog 5/005

Pos.				Weight kp	Type	Price EURO
1	Crane control unit standard design with heating/ventilator			48	KST 85	
2						
3	Crane control unit standard design without heating/ventilator			45	KST 87	
4						
5						
6	additional variations for driver's seat KFS 8 see catalog 2/138				KFS 8	
7						
8						
9						
10	Footrest mounted onto console adjustable ± 30 mm			8		
11						
12						
13						
14						
15						
16						
17						
18						
19						
20	Multi-axis controller	see catalog 1/100				
21	Single-axis controller	see catalog 1/200				
22	Double-handle controller	see catalog 1/160				
23	Control-switch	see catalog 1/220				
24	Command and indicating devices	see catalog 1/360				
30	Terminal block 4 mm ² without wiring each terminal				KL	
31	Terminal block 4 mm ² with wiring wire 1,5 mm ² each terminal				KL	
32	External wiring single wire highly flexible 1,5 mm ² 5 metre long					
33	Additional or subtract price each metre					
40	Special painted					
41	Indicating labels not engraved with 2 or 4 arrows					
42	Engraving, each 10 characters					

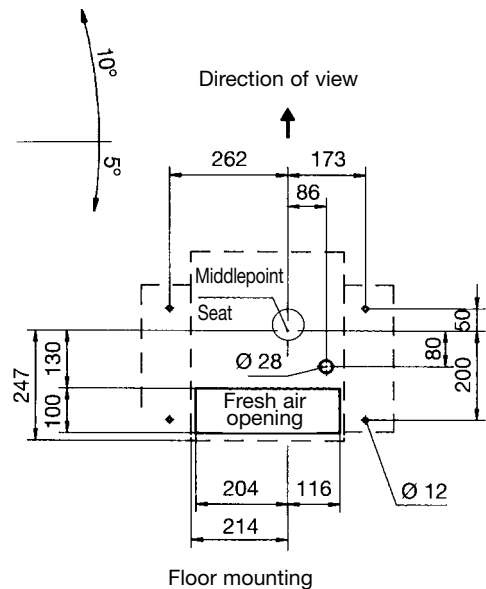
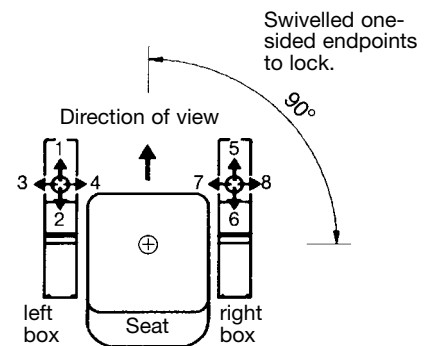
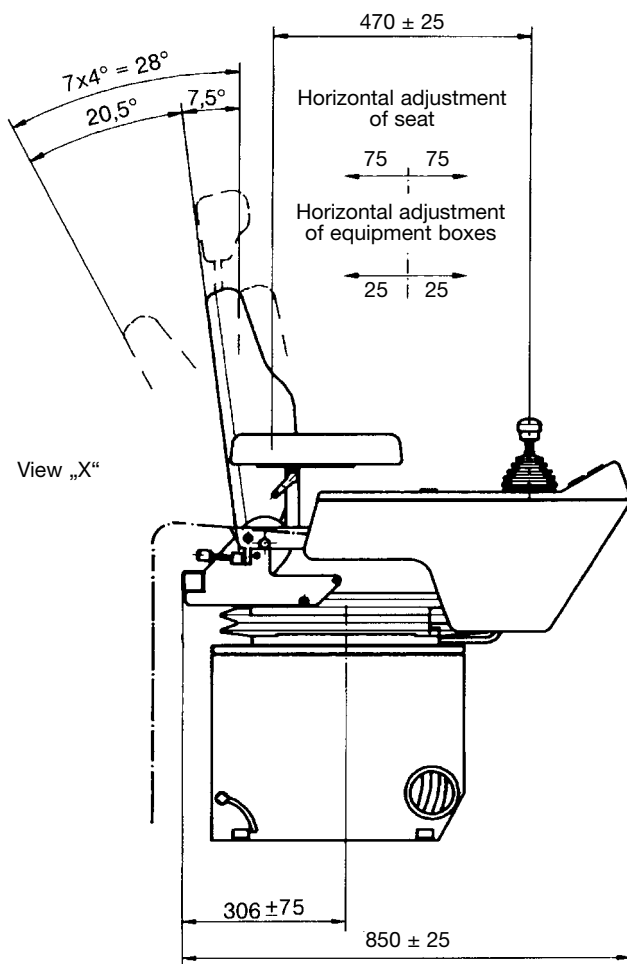
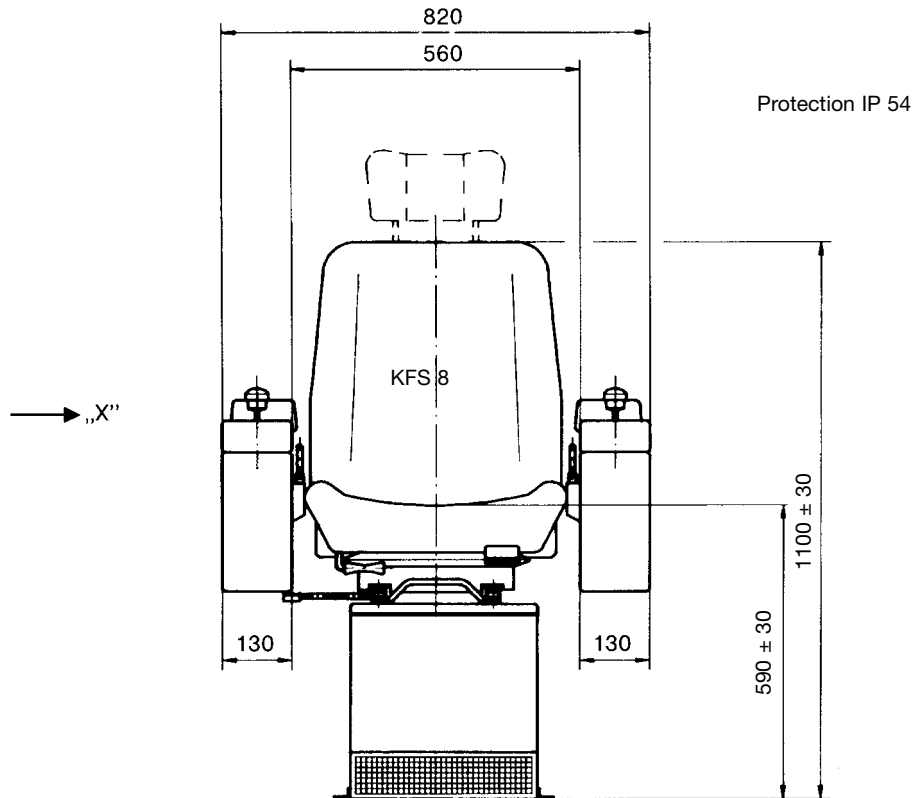



Type KST9KFS92-...

The swivelling crane control unit KST 9 is ergonomically designed and provides a high degree of comfort.

The standard design includes following:

Equipment boxes: plastic PU foam

The equipment boxes with the devices can be vertically and horizontally adjusted together with the armrests. Cabling is run through duct in the cross-member. (Terminal block).

Seat: Comfortable spring mounted seat KFS 6, with an oilhydraulic vibration absorption system, weight adjustment and air-permeable artificial leather or textil material, with headrest.

Adjusting possibilities: Seat horizontally and vertically. Inclination of cushion, backrest and armrest also adjustable. Weight setting for optimum spring suspension. Right equipment box turnable.

Cross-member: Steel section, top of which can be raised to lay cabling. The seat can be tilted backwards so that the cable duct in the cross-member is accessible.

Swivel base: Zero-end-float spring-loaded bearing. Rotational movement 180° right, 90° left, stopped by friction brake.

Surface treatment: Anti-corrosion primer, top coat: 2 coats of epoxy-resin paint, standard colour RAL 9011 black. textured varnish

All non-painted metal parts are electrogalvanized and chromed.

Permissible ambient temperature	Operation -40° C to +60° C
	Storage -50° C to +80° C
Climate resistance	
Damp heat constant	DIN IEC 68 part 2-3
Damp heat cyclic	DIN IEC 68 part 2-30
Degree of protection	IP 54 IEC 529 DIN 40050

Description data see catalog 5/006/007

Pos.				Weight kp	Type	Price EURO
1	Crane control unit standard design			48	KST 9	
2						
3						
4						
5						
6	additional variations for driver's seat KFS 6	see catalog 2/134			KFS 6	
7	Driver's seat KFS 9	see catalog 2/140			KFS 9	
8	Driver's seat KFS 10	see catalog 2/142			KFS 10	
9	Monitor mounting support left or right T 478			10		
10	Footrest mounted onto swivel base adjustable ± 30 mm			8		
11						
12						
13	Plate for horizontal manual adjustment of control unit adjustable ± 250 mm					
14	Manual adjustment of control unit vertical (gas loaded spring) adjustable 80 mm					
15						
16						
17						
18	Motorized adjustment of control unit swivelling (drive 24 V DC, seat height + 30 mm)					
19						
20	Multi-axis controller	see catalog 1/100				
21	Single-axis controller	see catalog 1/200				
22	Double-handle controller	see catalog 1/160				
23	Control-switch	see catalog 1/220				
24	Command and indicating devices	see catalog 1/360				
30	Terminal block 4 mm ² without wiring each terminal				KL	
31	Terminal block 4 mm ² with wiring wire 1,5 mm ² each terminal				KL	
32	External wiring single wire highly flexible 1,5 mm ² 5 metre long					
33	Additional or subtract price each metre					
40	Special painted					
41	Indicating labels not engraved with 2 or 4 arrows					
42	Engraving, each 10 characters					

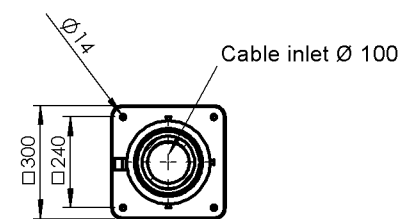
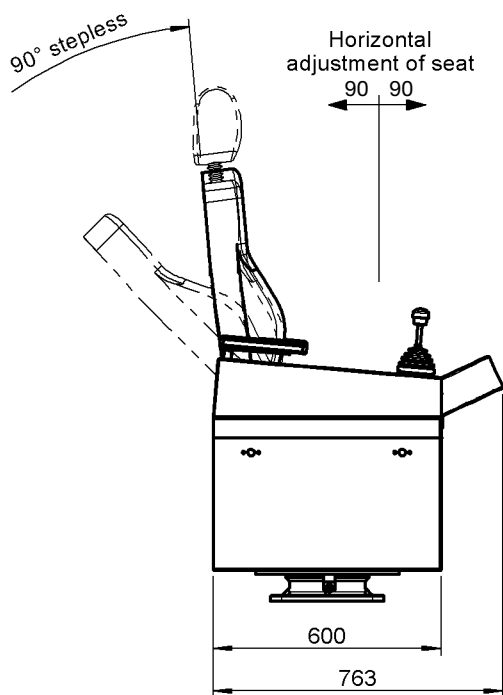
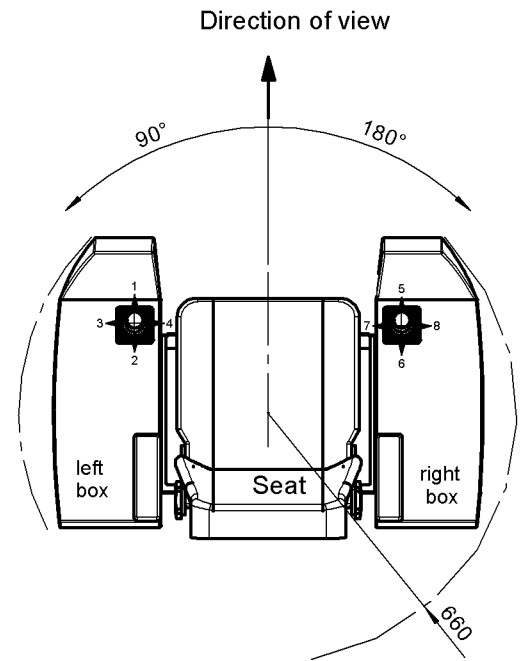
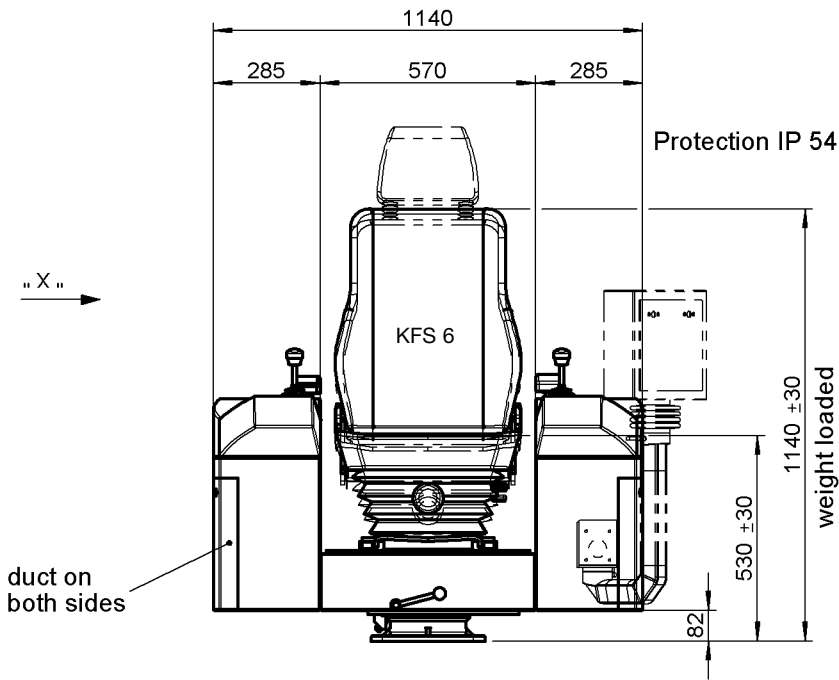

View "X"

Floor mounting



Type KST10KFS6-...

The swivelling crane control unit KST 10 is ergonomically designed and provides a high degree of comfort.

The standard design includes following:

Equipment boxes: plastic PU foam

The equipment boxes with the devices can be vertically and horizontally adjusted together with the armrests. Cabling is run through duct in the cross-member. (Terminal block).

Seat: Comfortable spring mounted seat KFS 6, with an oilhydraulic vibration absorption system, weight adjustment and air-permeable artificial leather or textil material, with headrest.

Adjusting possibilities: Seat horizontally and vertically. Inclination of cushion, backrest and armrest also adjustable. Weight setting for optimum spring suspension.

Cross-member: Steel section, top of which can be raised to lay cabling. The seat can be tilted backwards so that the cable duct in the cross-member is accessible.

Swivel base: Zero-end-float spring-loaded bearing. Rotational movement 180° right, 90° left, stopped by friction brake.

Surface treatment: Anti-corrosion primer, top coat: 2 coats of epoxy-resin paint, standard colour RAL 9011 black. textured varnish

All non-painted metal parts are electrogalvanized and chromed.

Permissible ambient temperature	Operation -40° C to +60° C
	Storage -50° C to +80° C
Climate resistance	
Damp heat constant	DIN IEC 68 part 2-3
Damp heat cyclic	DIN IEC 68 part 2-30
Degree of protection	IP 54 IEC 529 DIN 40050

Description data see catalog 5/008

Pos.				Weight kp	Type	Price EURO
1	Crane control unit standard design			48	KST 10	
2	Crane control unit standard design not swivelled			48	KST 101	
3	Crane control unit standard design without swivel base and cross-member			38	KST 102	
4						
5						
6	additional variations for driver's seat KFS 6 see catalog 2/134				KFS 6	
7						
8						
9						
10	Footrest mounted onto swivel base adjustable ± 30 mm			8		
11						
12						
13	Plate for horizontal manual adjustment of control unit adjustable ± 250 mm			95		
14						
15						
16						
17						
18						
19	Heating 2 x 2 kW with ventilator 230 V 50 Hz airvolume ca. 300 m³/h mounted on the swivel base sidewise					
20	Multi-axis controller see catalog 1/110					
21	Multi-axis controller see catalog 1/130					
22	Double-handle controller see catalog 1/162					
23	Control-switch see catalog 1/220					
24	Command and indicating devices see catalog 1/360					
30	Terminal block 4 mm² without wiring each terminal				KL	
31	Terminal block 4 mm² with wiring wire 1,5 mm² each terminal				KL	
32	External wiring single wire highly flexible 1,5 mm² 5 metre long					
33	Additional or subtract price each metre					
40	Special painted					
41	Indicating labels not engraved with 2 or 4 arrows					
42	Engraving, each 10 characters					

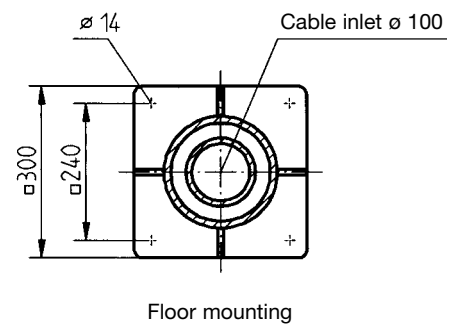
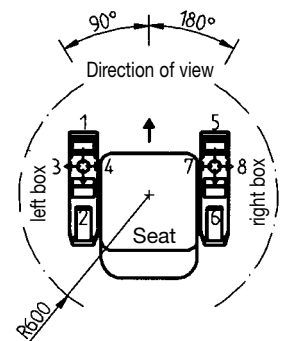
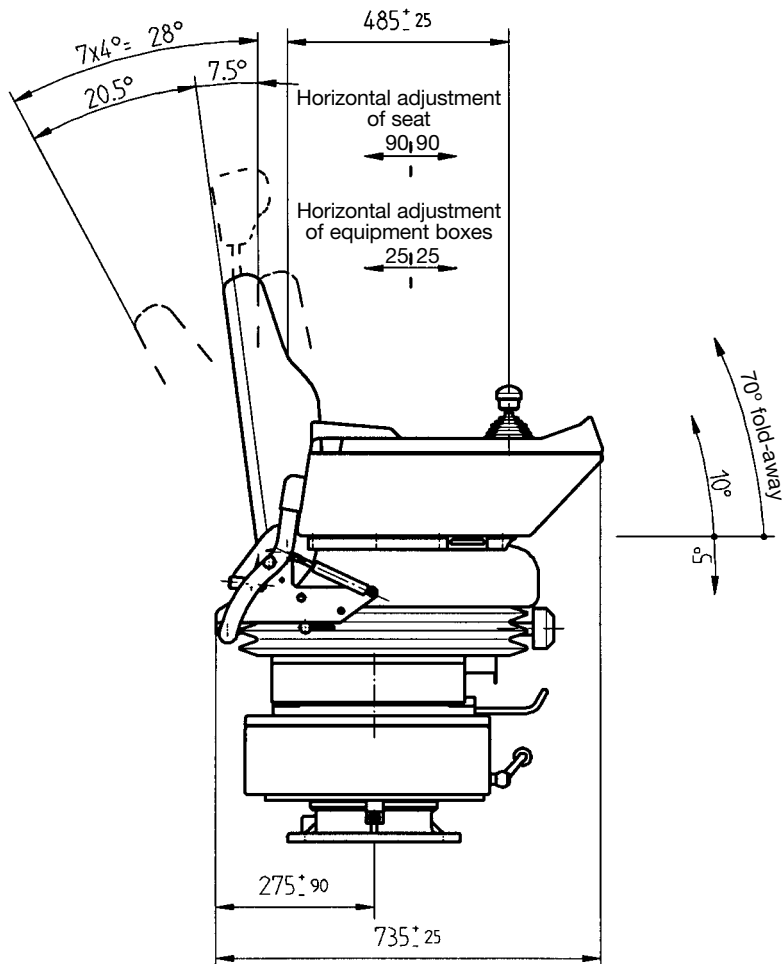
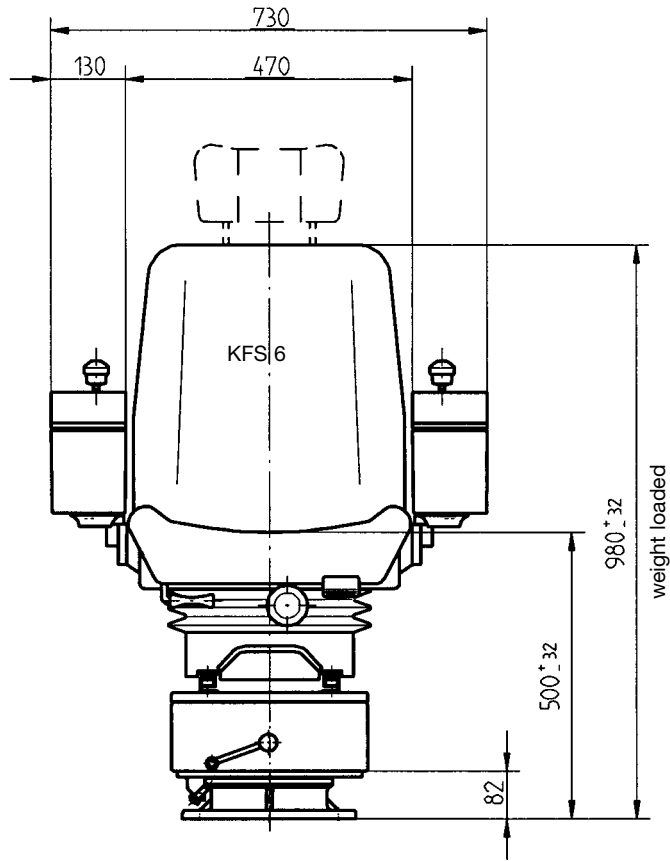



Type KST15XKFS92-...

The swivelling crane control unit KST 15 is ergonomically designed and provides a high degree of comfort.

The standard design includes following:

Equipment boxes: Sheet steel. The top panel of the equipment box with the devices can be raised and locked in position. The terminal strip is easily accessible via an opening on the inside that can be closed with a lockable cover. The external wiring is run through duct from the equipment boxes in the cross-member.

Seat: Comfortable spring mounted seat KFS 10, with a pneumatic vibration absorption system by compressor 24 V DC, weight adjustment and airpermeable artificial leather or textil material, with headrest, with armrests.

Manual adjustments: Seat horizontally and vertically. Inclination of cushion, backrest and armrest also adjustable. Weight setting for optimum spring suspension.

Motorized adjustments: Seat with equipment boxes vertical (inclinations adjustments forward/backward). Seat with equipment boxes horizontal. Selector switches for motorized-drives are in the equipment box. Motor 24 V DC ca. 15 ampere.

Cross-member: Steel section, top of which can be raised to lay cabling. The seat with the boxes can be tilted forwards so that the cable duct in the cross-member is accessible.

Swivel base: Zero-end-float spring-loaded bearing. Rotational movement 180° right, 90° left, stopped by friction brake.

Surface treatment: Anti-corrosion primer, top coat: 2 coats of epoxy-resin paint, standard colour RAL 7032 pebble-grey. textured varnish. All non-painted metal parts are electrogalvanized and chromed.

Description data see catalog 5/003/004

Permissible ambient temperature	Operation -40° C to +60° C Storage -50° C to +80° C
Climate resistance	
Damp heat constant	DIN IEC 68 part 2-3
Damp heat cyclic	DIN IEC 68 part 2-30
Degree of protection	IP 54 IEC 529 DIN 40050

Pos.				Weight kp	Type	Price EURO
1	Crane control unit standard design	Equipment boxes 200 x 580 mm		236	KST 151	
2	Crane control unit standard design	Equipment boxes 270 x 580 mm		240	KST 152	
3						
4	Crane control unit standard design	Equipment boxes 320 x 580 mm		244	KST 154	
5	Crane control unit standard design	Equipment boxes special dimensions			KST 15x	
6	additional variations for driver's seat KFS 10 see catalog 2/142				KFS 10	
7	Driver's seat KFS 6	see catalog 2/134			KFS 6	
8	Driver's seat KFS 9	see catalog 2/140			KFS 9	
9	Monitor mounting support left or right			10		
10	Footrest (required) mounted onto swivel base adjustable ± 30 mm			8		
11						
12	Plate for horizontal manual adjustment of control unit adjustable ± 250 mm			95		
13						
14						
15	Motorized adjustment of equipment boxes vertical adjustable ± 25 mm 24 V DC					
16	Motorized adjustment of equipment boxes horizontal adjustable ± 40 mm 24 V DC					
17						
18	Motorized adjustment of control unit swivelling (drive 24 V DC, seat height + 70 mm)			18		
19	Heating 2 x 2 kW with ventilator 230 V 50 Hz airvolume ca. 300 m³/h mounted on the swivel base sidewise					
20	Multi-axis controller	see catalog 1/100				
21	Single-axis controller	see catalog 1/200				
22	Double-handle controller	see catalog 1/160				
23	Control-switch	see catalog 1/220				
24	Command and indicating devices	see catalog 1/360				
30	Terminal block 4 mm² without wiring each terminal				KL	
31	Terminal block 4 mm² with wiring wire 1,5 mm² each terminal				KL	
32	External wiring single wire highly flexible 1,5 mm² 5 metre long					
33	Additional or subtract price each metre					
40	Special painted					
41	Indicating labels not engraved with 2 or 4 arrows					
42	Engraving, each 10 characters					

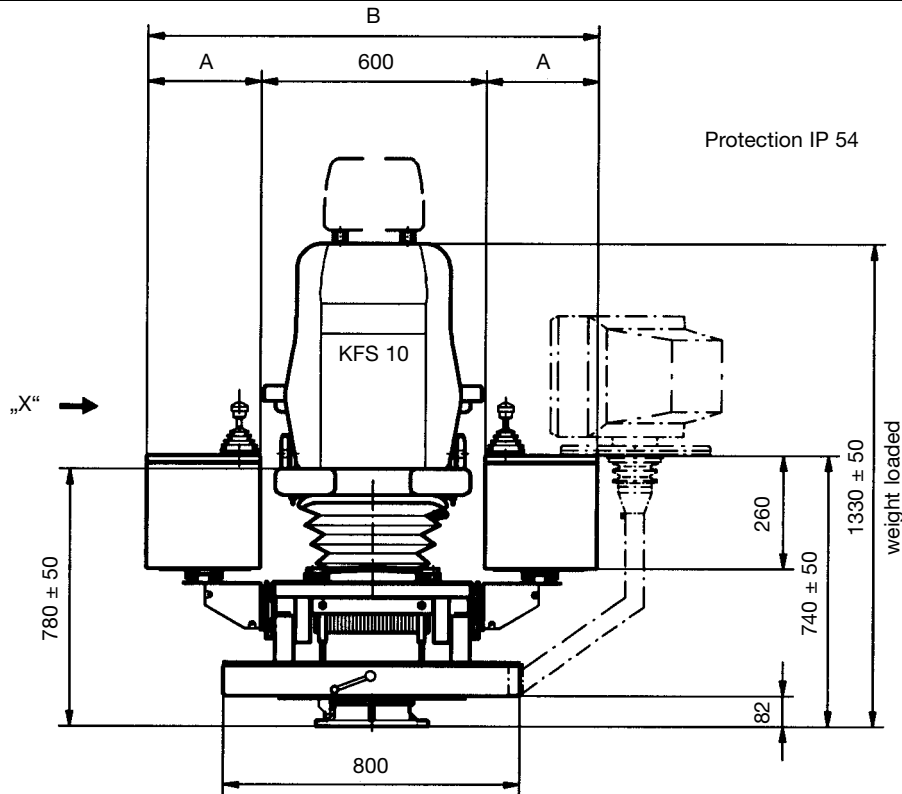

Type	Dimension A	Dimension B	Dimension C
KST 151	200	1000	800
KST 152	270	1140	845
KST 154	320	1240	880

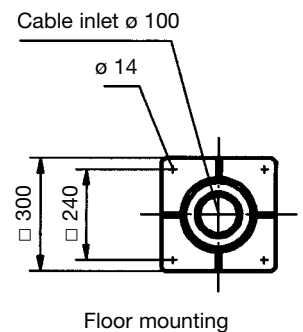
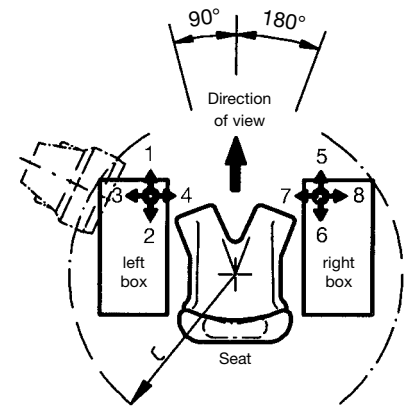
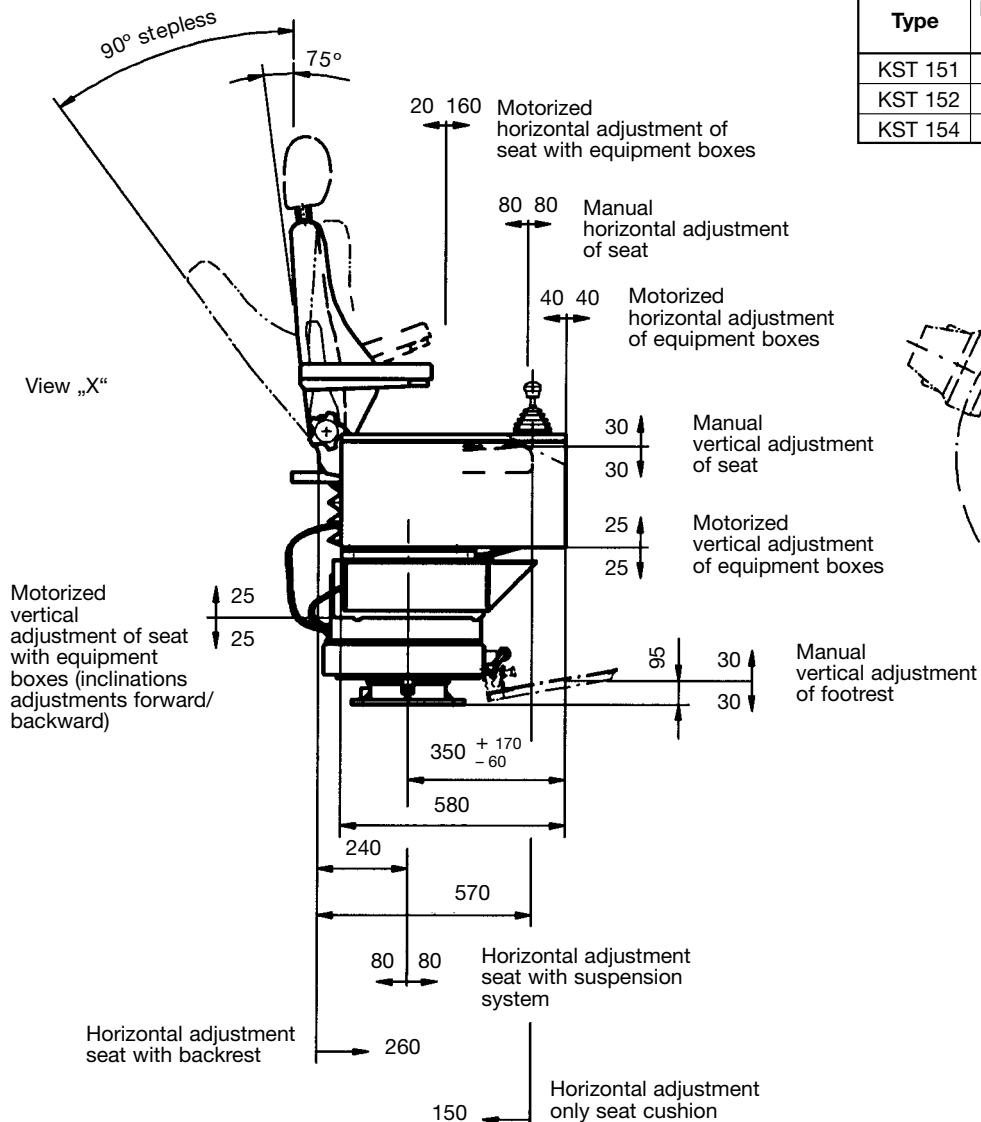



Type KST181KFS92-...

The swivelling crane control unit KST 18 is ergonomically designed and provides a high grade of comfort.

The standard design includes following:

Equipment boxes: Sheet steel. The top panel of the equipment box with the devices can be raised and locked in position and is provided with armrests. Cabling is run through duct from the equipment boxes in the cross-member. (Terminal block).

Seat: Comfortable spring mounted seat KFS 9, with an oilhydraulic vibration absorption system, weight adjustment and airpermeable artificial leather or textil material, with headrest.

Manual adjustments: Seat horizontally and vertically. Inclination of cushion, backrest and armrest also adjustable. Weight setting for optimum spring suspension. Equipment boxes horizontally and vertically.

Motorized adjustments: Seat with equipment boxes vertical (inclinations adjustments forward/backward). Seat with equipment boxes horizontal. Selector switches for motorized-drives are in the equipment box. Motor 24 V DC ca. 15 ampere.

Cross-member: Steel section, top of which can be raised to lay cabling. The seat with the boxes can be tilted forwards so that the cable duct in the cross-member is accessible.

Swivel base: Zero-end-float spring-loaded bearing. Rotational movement 180° right, 90° left, stopped by friction brake.

Surface treatment: Anti-corrosion primer, top coat: 2 coats of epoxy-resin paint, standard colour RAL 7032 pebble-grey. textured varnish

All non-painted metal parts are electrogalvanized and chromed.

Description data see catalog 5/003/004

Permissible ambient temperature	Operation -40° C to +60° C Storage -50° C to +80° C
Climate resistance	
Damp heat constant	DIN IEC 68 part 2-3
Damp heat cyclic	DIN IEC 68 part 2-30
Degree of protection	IP 54 IEC 529 DIN 40050

Pos.				Weight kp	Type	Price EURO
1	Crane control unit standard design	Equipment boxes 160 x 420 mm		148	KST 181	
2	Crane control unit standard design	Equipment boxes 200 x 420 mm		150	KST 182	
3						
4						
5	Crane control unit standard design	Equipment boxes special dimensions			KST 18x	
6	additional variations for driver's seat KFS 6	see catalog 2/134			KFS 6	
7	Driver's seat KFS 9	see catalog 2/140			KFS 9	
8						
9						
10	Footrest (required) mounted onto swivel base adjustable ± 30 mm			8		
11						
12						
13	Plate for horizontal manual adjustment of control unit adjustable ± 250 mm			95		
14						
15						
16						
17						
18	Motorized adjustment of control unit swivelling (drive 24 V DC, seat height + 30 mm)			16		
19	Heating 2 x 2 kW with ventilator 230 V 50 Hz airvolume ca. 300 m³/h mounted on the swivel base sidewise					
20	Multi-axis controller	see catalog 1/100				
21	Single-axis controller	see catalog 1/200				
22	Double-handle controller	see catalog 1/160				
23	Control-switch	see catalog 1/220				
24	Command and indicating devices	see catalog 1/360				
30	Terminal block 4 mm² without wiring each terminal				KL	
31	Terminal block 4 mm² with wiring wire 1,5 mm² each terminal				KL	
32	External wiring single wire highly flexible 1,5 mm² 5 metre long					
33	Additional or subtract price each metre					
40	Special painted					
41	Indicating labels not engraved with 2 or 4 arrows					
42	Engraving, each 10 characters					

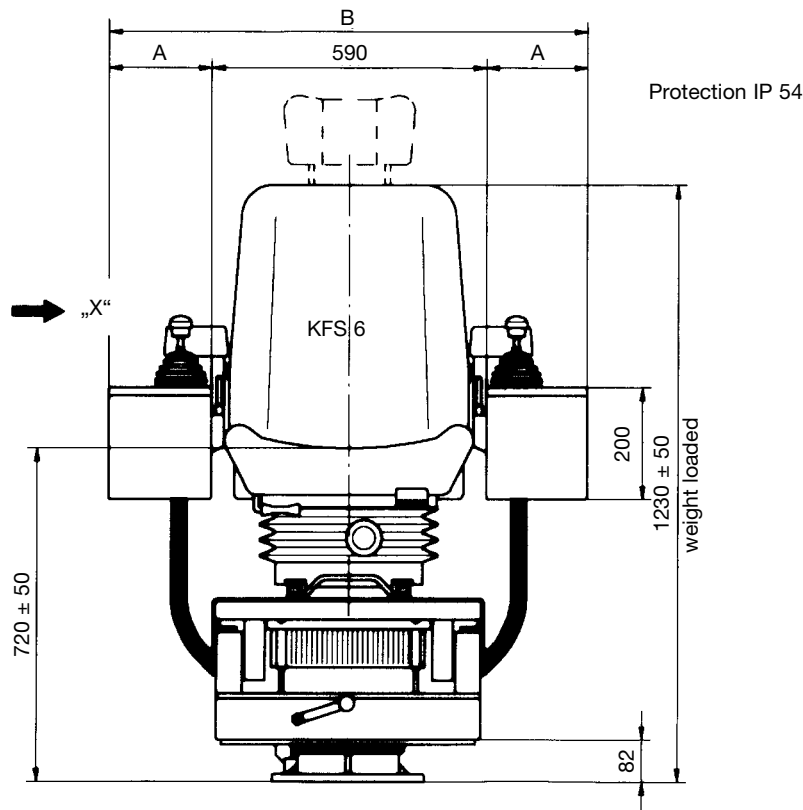

Type	Dimension A	Dimension B	Dimension C
KST 181	160	910	<625 >815
KST 182	200	990	<655 >835

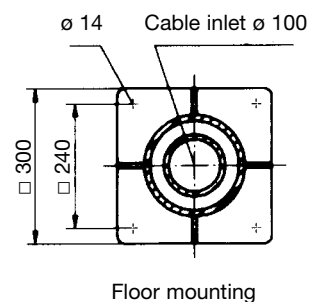
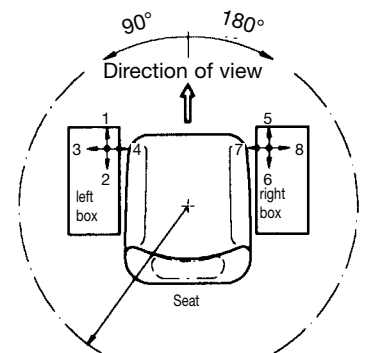
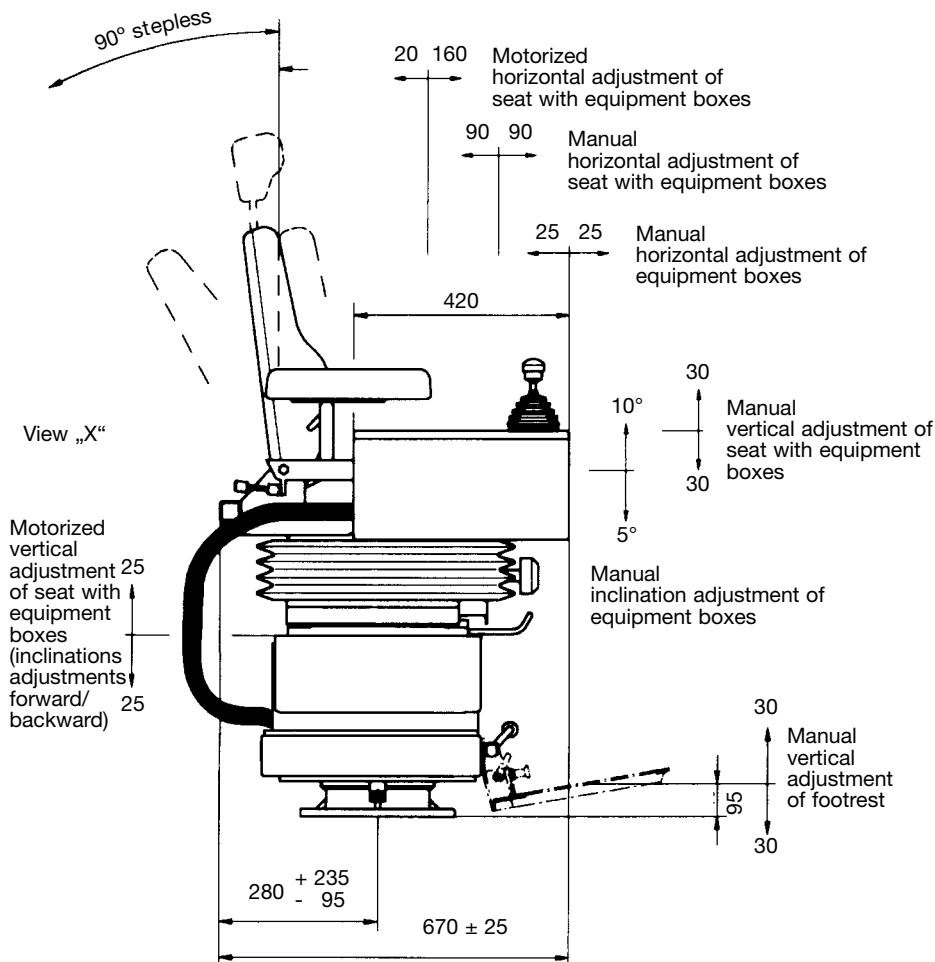

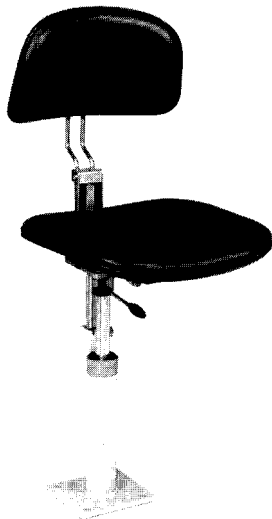

Type KFS2

The crane driver's seat KFS 2 has stepless high adjustment by means of a gas-loaded spring.

The backrest can be tilted, forwards onto the cushion, which in turn can then be tilted 90° sideways.

All these functions are performed easily via levers.

The metal parts are protected against corrosion and painted black.

Technical details:

Horizontal adjustment	100 mm
Backrest adjustment, fine control inclination backwards	max. 10°
Height adjustment	120 mm

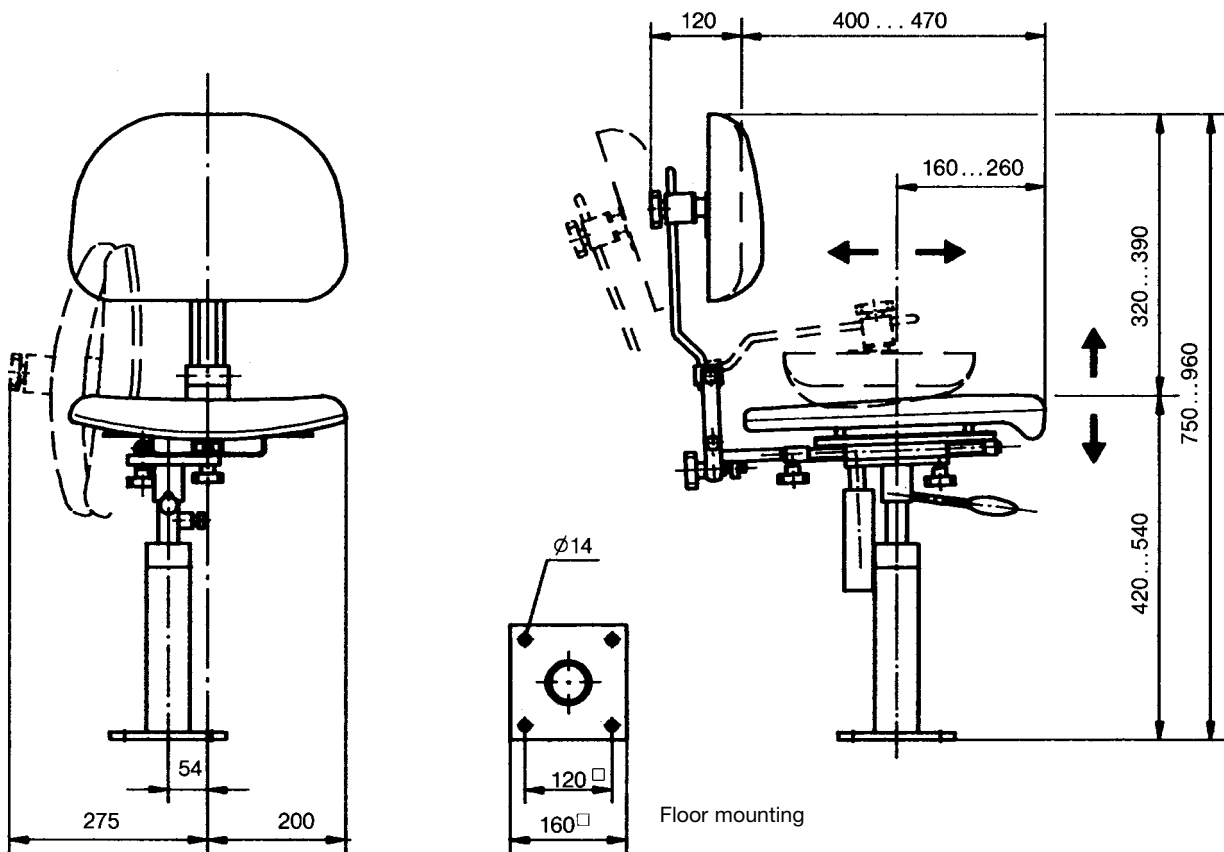

Pos.		Weight kp	Type	Price EURO
1	Driver's seat with air-permeable artificial leather cover black	15	KFS 21	
2	Driver's seat with textil cover grey / black	14	KFS 22	
3				
4				
5				
6				
7				
8				
9				
10				



Type KFS4

The crane driver's seat KFS 4 has stepless high adjustment by means of a gas-loaded spring and an oilhydraulic vibration absorption system with weight adjustment.

The backrest can be tilted, forwards onto the cushion, which in turn can then be tilted 90° sideways.

All these functions are performed easily via levers.

The metal parts are protected against corrosion and painted black.

Technical details:

Suspension stroke	80 mm
Weight adjustment	50-130 kg
Horizontal adjustment	150 mm
Backrest adjustment, fine control inclination backwards	max. 20°
Height adjustment	100 mm

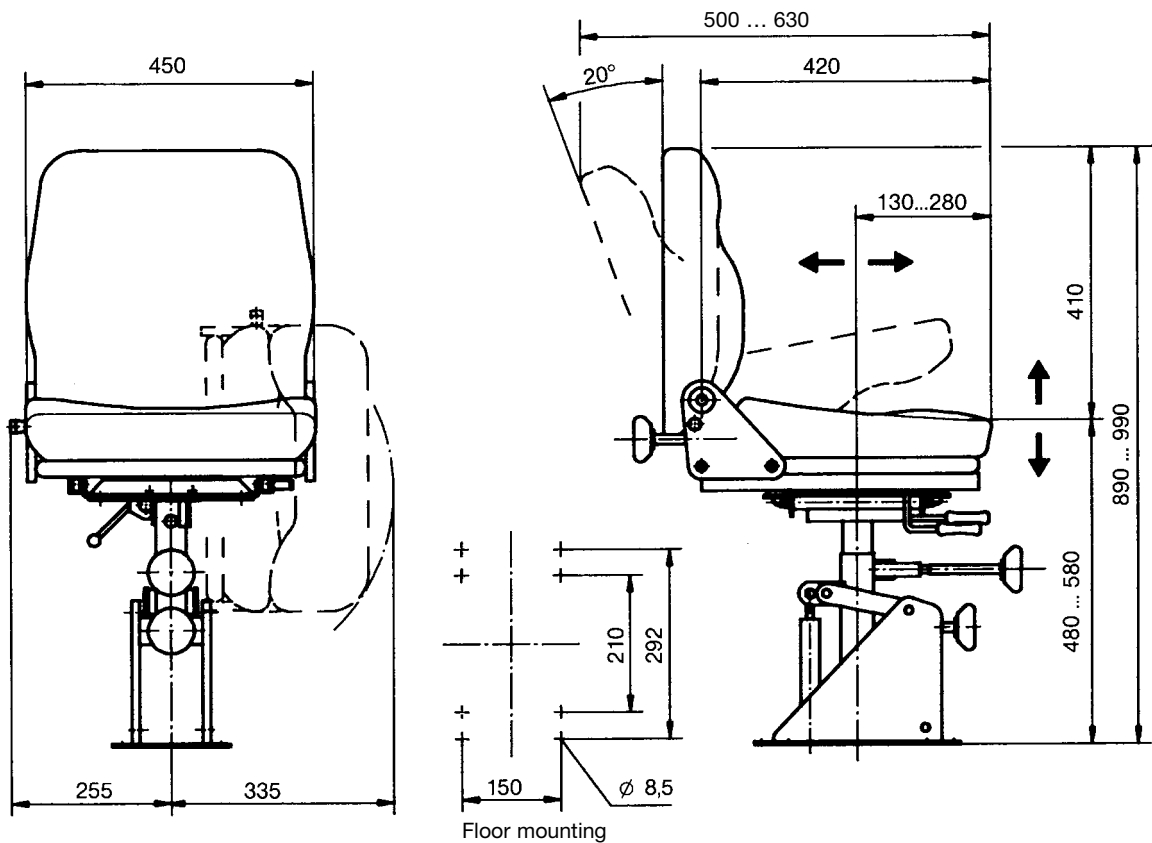

Pos.		Weight kp	Type	Price EURO
1	Driver's seat with air-permeable artificial leather cover black	24	KFS 41	
2	Driver's seat with textil cover grey / black	24	KFS 42	
3				
4	Armrest fully adjustable (2 pieces) 50 mm wide			
5	Armrest fully adjustable (2 pieces) 100 mm wide			
6				
7				
8				
9				
10				



Type KFS62-2-5-6-24

The crane driver's seat KFS 6 is ergonomically designed and provides a high grade of comfort.

The driver's seat is a low level mechanical suspension seat with an oilhydraulic vibration absorption system with weight adjustment.

All adjustment controls are positioned ergonomically within easy access.

For this comfort driver's seat KFS 6 a lot of efficient accessories are available look Pos. 5-25.

The metal parts are protected against corrosion and painted black.

Technical detail:

Suspension stroke	95 mm
Weight adjustment	40-130 kg
Horizontal adjustment	180 mm
Backrest adjustment, fine control inclination backwards	28° (90°)
Height and slope adjustment	65 mm

Pos.				Weight kp	Type	Price EURO
1	Driver's seat standard design with air-permeable artificial leather cover black			25	KFS 61	
2	Driver's seat standard design with textil cover grey / yellow			25	KFS 62	
3						
4						
5	Headrest raint					
6	Armrest fully adjustable (2 pieces) 50 mm wide					
7	Armrest fully adjustable (2 pieces) 100 mm wide					
8	Backrest high + 100 mm inclination backwards max. 90°					
9	Backrest standard with lumbar support manual adjustment					
10						
11	Seat cushion deep adjustment mechanical 60 mm					
12						
13	Seat contact 1 NO 1,5 A 24 V DC					
14	Seat cushion and backrest standard with heating element 24 V DC 42 Watt					
15						
16	Safety belt 2 point fixing					
17	Safety belt 4 point fixing (trouser braces belt) (Pos. 5 additionally required)					
18						
19						
20						
21						
22						
23						
24	Console			10		
25						

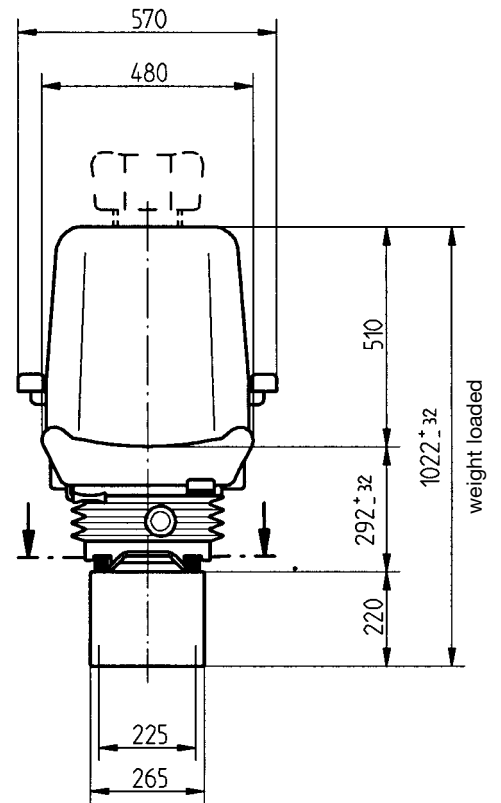
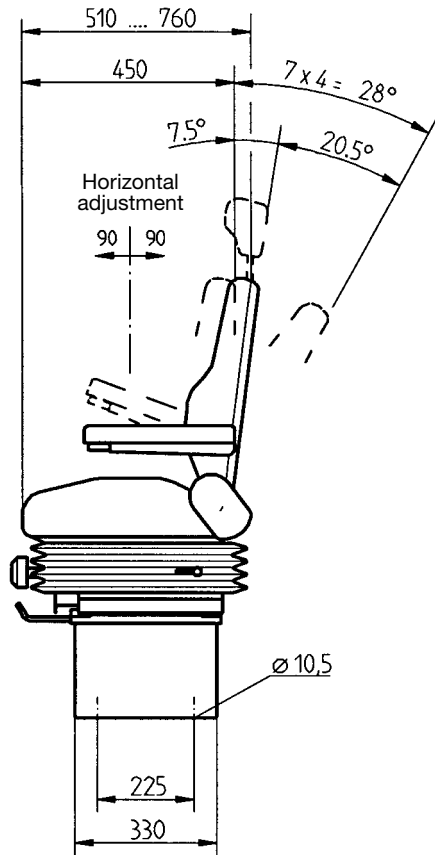

seat slide fastener dimension

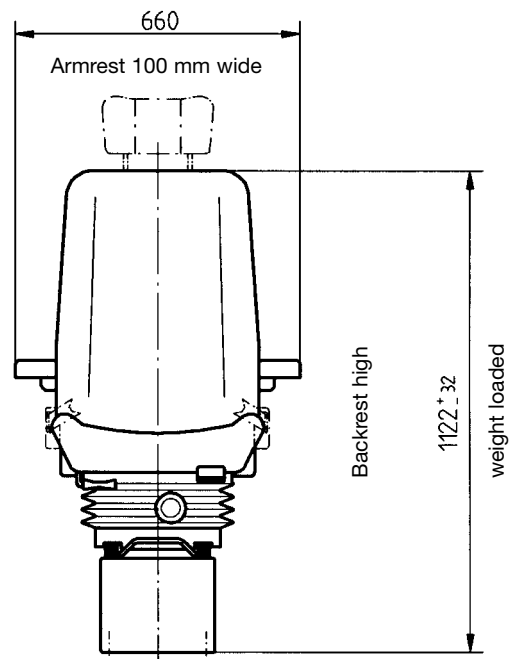
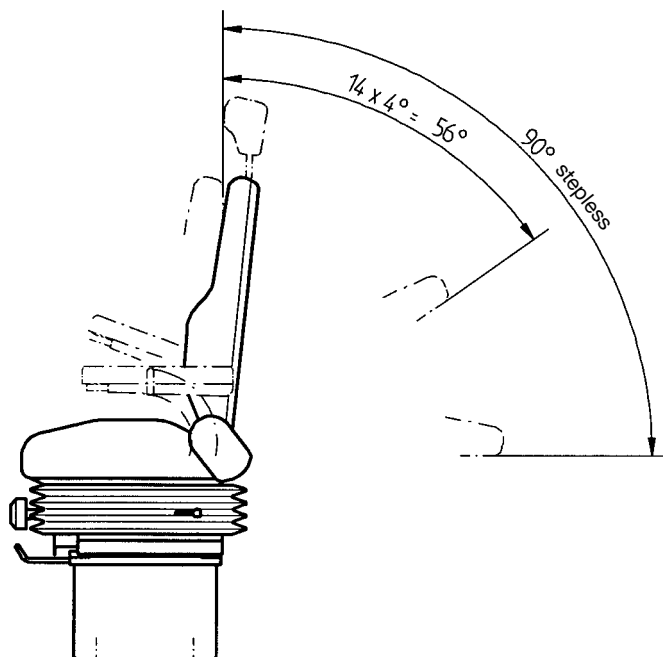
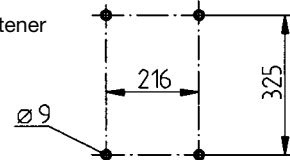



Type KFS72-2-5-7-24

The crane driver's seat KFS 7 is ergonomically designed and provides a high grade of comfort.

The driver's seat is a low level mechanical suspension seat with an oilhydraulic vibration absorption system with weight adjustment.

All adjustment controls are positioned ergonomically within easy access.

For this comfort driver's seat KFS 7 a lot of efficient accessories are available look Pos. 5-25.

The metal parts are protected against corrosion and painted black.

Technical detail:

Suspension stroke	60 mm
Weight adjustment	40-130 kg
Horizontal adjustment	180 mm, dual 300 mm
Backrest adjustment, fine control inclination backwards	28° (90°)
Height and slope adjustment	65 mm

Pos.				Weight kp	Type	Price EURO
1	Driver's seat standard design with air-permeable artificial leather cover black			25	KFS 71	
2	Driver's seat standard design with textil cover grey / yellow			25	KFS 72	
3						
4						
5	Headrest raint					
6	Armrest fully adjustable (2 pieces) 50 mm wide					
7	Armrest fully adjustable (2 pieces) 100 mm wide					
8	Backrest high + 100 mm inclination backwards max. 90°					
9	Backrest standard with lumbar support manual adjustment					
10						
11	Seat cushion deep adjustment mechanical 60 mm					
12	Seat cushion V-cut (free sight to down)					
13	Seat contact 1 NO 1,5 A 24 V DC					
14	Seat cushion and backrest standard with heating element 24 V DC 42 Watt					
15						
16	Safety belt 2 point fixing					
17	Safety belt 4 point fixing (trouser braces belt) (Pos. 5 additionally required)					
18						
19	Horizontal adjustment dual 180 + 120 mm (total 300 mm)					
20						
21						
22						
23						
24	Console			10		
25						

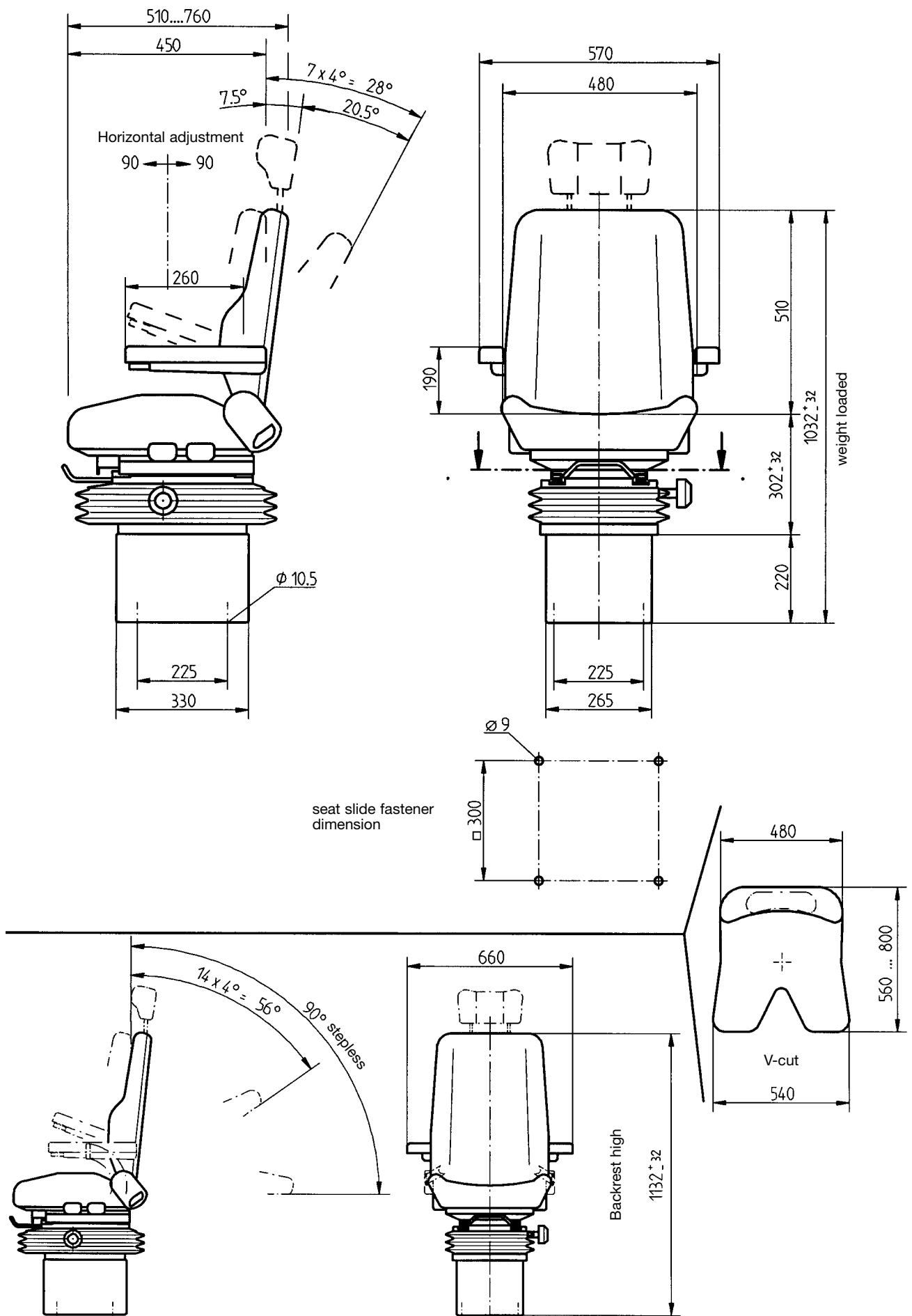



Type KFS82-2-5-6-24-25

The crane driver's seat KFS 8 is a static seat with ergonomically designed and provides a high grade of comfort.

The driver's seat KFS 8 is equipped with roller-bearing swivel system.

All adjustment controls are positioned ergonomically within easy access.

For this comfort driver's seat KFS 8 a lot of efficient accessories are available look Pos. 5-25.

The console are available to build in the heating 2-steps 2 x 2 kW 380 V AC, ventilator 380 V AC, airvolume ca. 1000 m³/h, air circulation (opening in the underside of the console), selector switch for heating / ventilator.

The metal parts are protected against corrosion and painted black.

Technical detail:

Horizontal adjustment 150 mm

Backrest adjustment, fine control inclination backwards 28°

Height and slope adjustment 65 mm

Pos.				Weight kp	Type	Price EURO
1	Driver's seat standard design with air-permeable artificial leather cover black			25	KFS 81	
2	Driver's seat standard design with textil cover grey / black			25	KFS 82	
3						
4						
5	Headrest raint					
6	Armrest fully adjustable (2 pieces) 50 mm wide					
7	Armrest fully adjustable (2 pieces) 100 mm wide					
8	Backrest high + 100 mm inclination backwards max. 90°					
9	Backrest with lumbar support manual adjustment					
10						
11	Seat cushion deep adjustment mechanical 60 mm					
12						
13						
14	Seat cushion and backrest standard with heating element 24 V DC 42 Watt					
15						
16	Safety belt 2 point fixing					
17	Safety belt 4 point fixing (trouser braces belt) (Pos. 5 additionally required)					
18						
19						
20						
21						
22						
23	Roller-bearing swivel system for seat (included in Pos. 1, 2)					
24	Console			10		
25	Heating 2 steps 2 x 2 kW 380 V AC with ventilator 380 V AC airvolume ca. 1000 m ³ /h with selector switch for heating / ventilator mounting into the console			10		

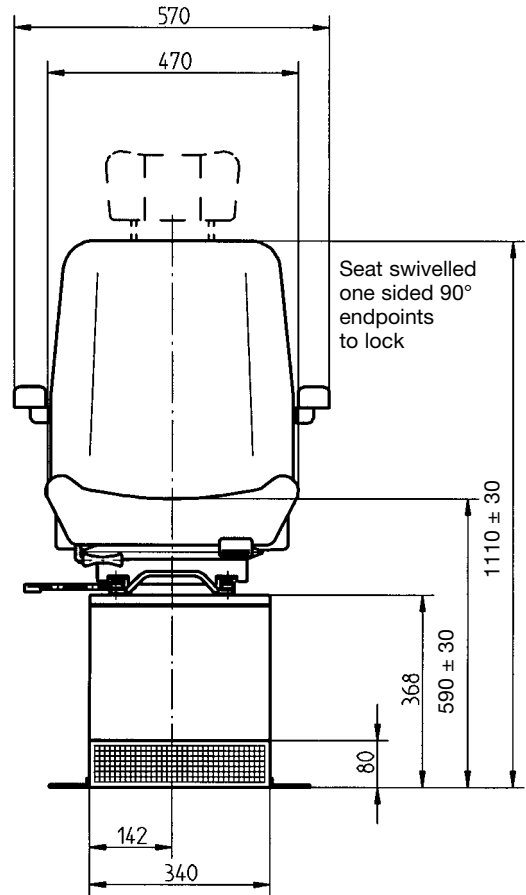
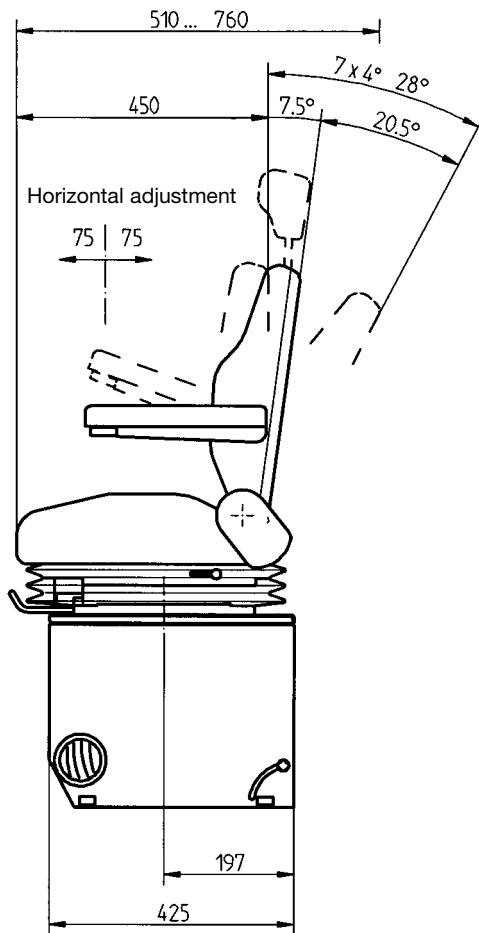

seat slide fastener dimension

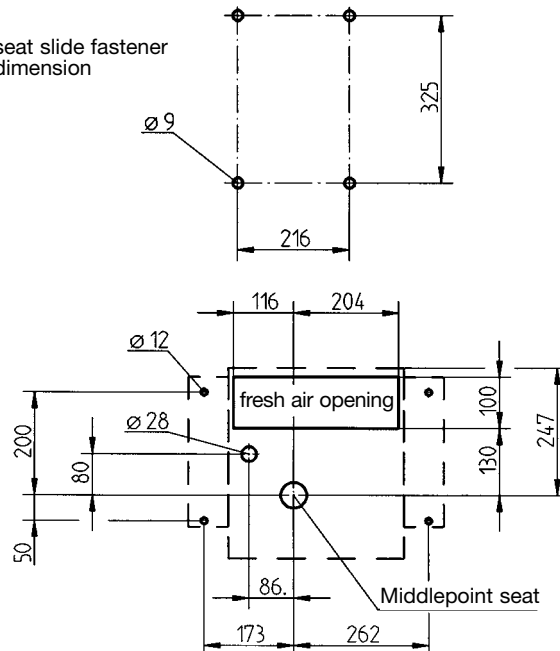



Type KFS92-2-5-6-24

The crane driver's seat KFS 9 is ergonomically designed and provides a high grade of comfort.

The driver's seat is a low level mechanical suspension seat with an oilhydraulic vibration absorption system with weight adjustment.

All adjustment controls are positioned ergonomically within easy access.

For this comfort driver's seat KFS 9 a lot of efficient accessories are available look Pos. 5-25.

The metal parts are protected against corrosion and painted black.

Technical detail:

Suspension stroke	80 mm
Weight adjustment	50-120 kg
Horizontal adjustment	160 mm
Backrest adjustment stepless inclination backwards	90°
Height and slope adjustment	60 mm

Pos.				Weight kp	Type	Price EURO
1	Driver's seat standard design with air-permeable artificial leather cover black			25	KFS 91	
2	Driver's seat standard design with textil cover grey / black			25	KFS 92	
3						
4						
5	Headrest raint					
6	Armrest adjustable (2 pieces) 50 mm wide					
7	Armrest adjustable (2 pieces) 100 mm wide					
8						
9	Backrest with lumbar support manual adjustment 2 movement					
10	Backrest with lumbar support manual adjustment 4 movement					
11						
12	Seat cushion V-cut (free sight to down) (Pos. 19 required)					
13	Seat contact 1 NO 1,5 A 24 V DC					
14	Seat cushion and backrest standard with heating element 24 V DC 47 Watt					
15	Seat cushion deep prolongation + 35 mm					
16	Safety belt 2 point fixing					
17	Safety belt 4 point fixing (trouser braces belt) (Pos. 5 additionally required)					
18						
19	Horizontal adjustment dual 160 + 120 mm (total 280 mm seat height + 30 mm)					
20	Pneumatic vibration absorption system with weight adjustment by compressor 24 V DC 8 Ampere					
21	Plate for horizontal manual adjustment of seat adjustable 500 mm with floor mounting plate					
22						
23	Loose cover					
24	Console					
25						

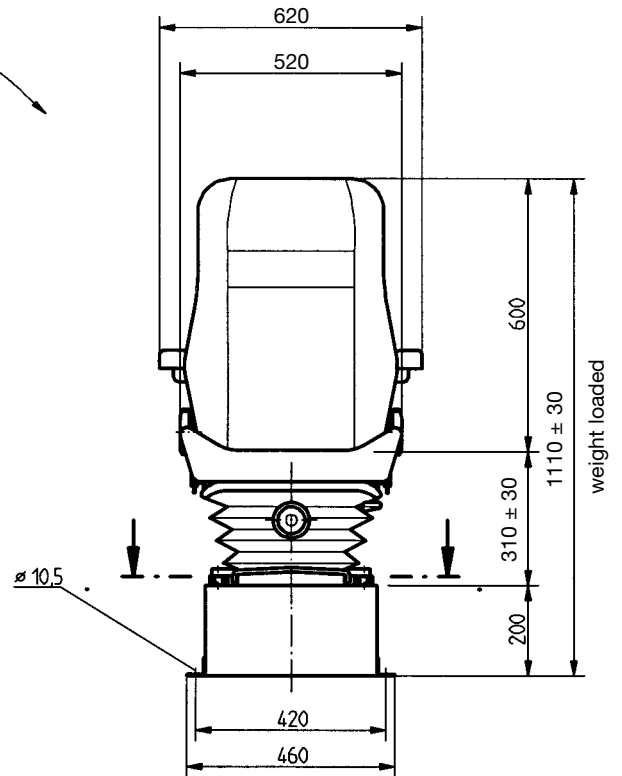
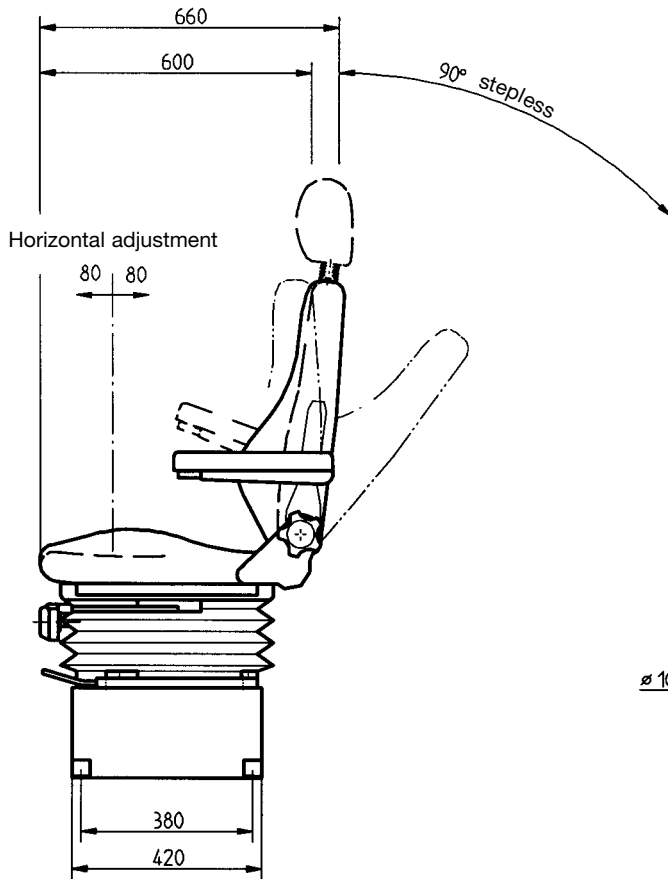

manual adjustment of seat
adjustable 500 mm

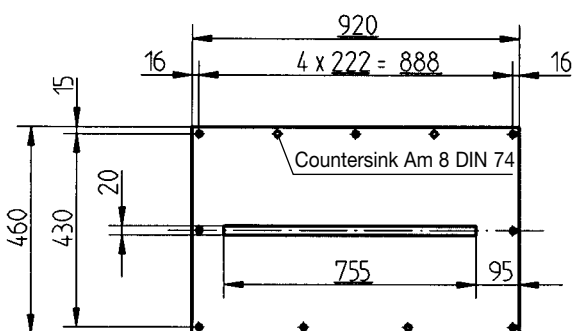
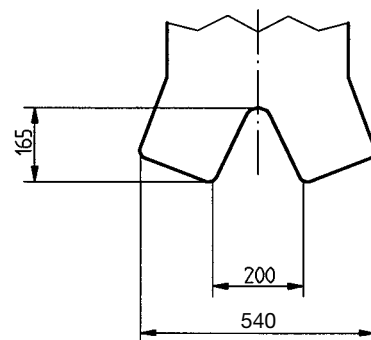
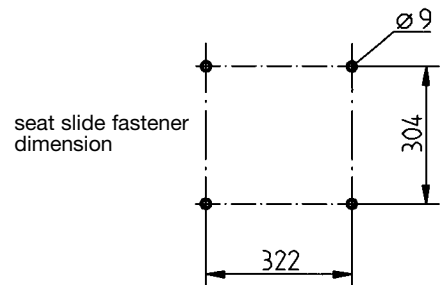
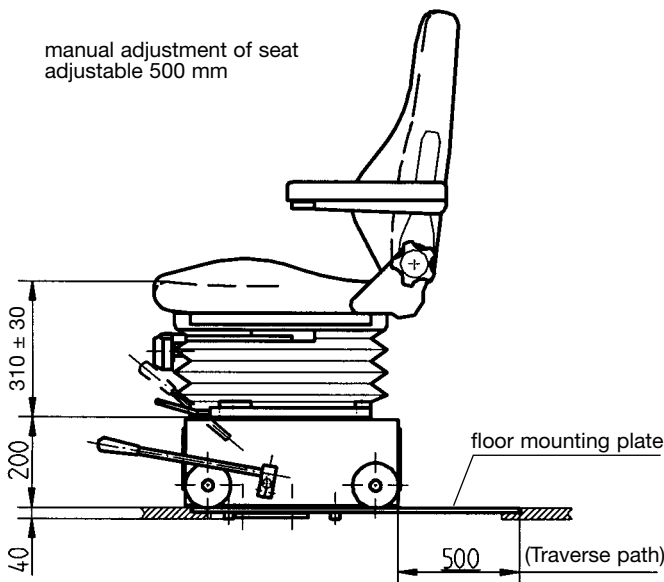



Type KFS102-2-5-7-12-24

The crane driver's seat KFS 10 is ergonomically designed and provides a high grade of comfort.

The driver's seat is a low level mechanical suspension seat with a pneumatic vibration absorption system with weight adjustment by compressor 24 V DC 8 Ampere.

All adjustment controls are positioned ergonomically within easy access.

For this comfort driver's seat KFS 10 a lot of efficient accessories are available look Pos. 5-25.

The metal parts are protected against corrosion and painted black.

Technical detail:

Suspension stroke pneumatic	80 mm
Weight adjustment	50-130 kg
Horizontal adjustment seat with suspension system	160 mm
Horizontal adjustment seat with backrest	260 mm
Horizontal adjustment only seat cushion	150 mm
Backrest adjustment stepless inclination backwards	90°
Height and slope adjustment mechanical	60 mm

Pos.				Weight kp	Type	Price EURO
1	Driver's seat standard design with air-permeable artificial leather cover black			25	KFS 101	
2	Driver's seat standard design with textil cover grey / black			25	KFS 102	
3						
4						
5	Headrest raint					
6	Armrest adjustable (2 pieces) 50 mm wide					
7	Armrest adjustable (2 pieces) 100 mm wide					
8						
9	Backrest with lumbar support manual adjustment 2 movement					
10	Backrest with lumbar support manual adjustment 4 movement					
11						
12	Seat cushion V-cut (free sight to down)					
13	Seat contact 1 NO 1,5 A 24 V DC					
14	Seat cushion and backrest standard with heating element 24 V DC 47 Watt					
15						
16	Safety belt 2 point fixing					
17	Safety belt 4 point fixing (trouser braces belt) (Pos. 5 additionally required)					
18						
19						
20						
21						
22						
23						
24	Console			10		
25						

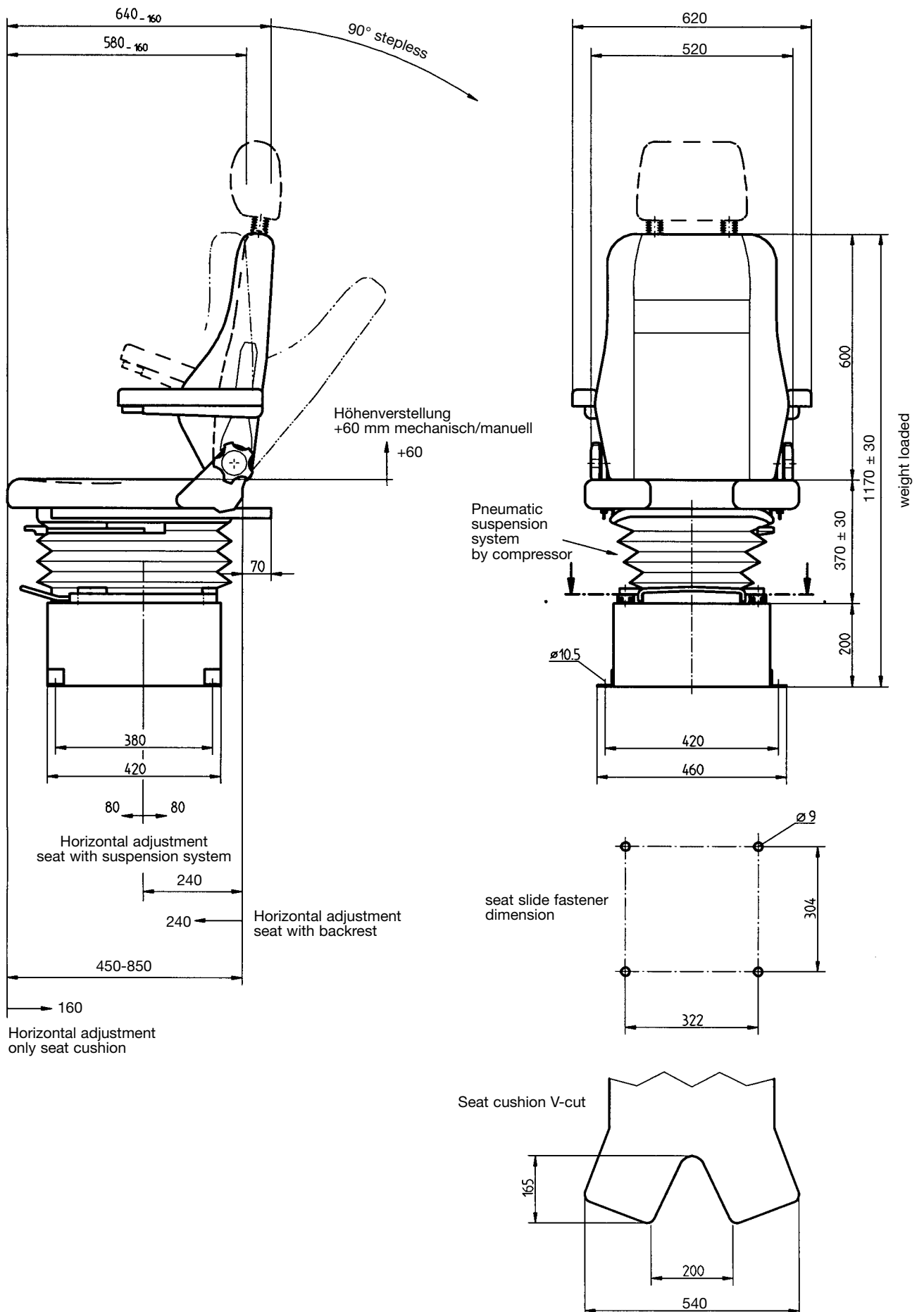



Type TS1-1-5

The portable control unit TS 1 accommodates all the devices necessary for control and monitoring. The chest panel and straps enable the operator to carry it without becoming tired. An adjustable carrying strap can also be fitted for use without the chest plate.

The control console is made of polyester (glass fibre reinforced plastic).
Colour RAL 7032 pebble-grey.
It can also be supplied as RAL 1021 yellow.

Permissible ambient temperature

Operation -40° C to +60° C
Storage -50° C to +80° C

Climate resistance
Damp heat constant
Damp heat cyclic
Degree of protection

DIN IEC 68 part 2-3
DIN IEC 68 part 2-30
control unit IP 65 with
multi-axis controller IP 54
to IEC 529 DIN 40050

Pos.					Weight gramm	Type	Price EURO
1	Control unit with chest plate and straps				3300	TS 1	
2	Control unit with straps				3000	TS 11	
3							
4	Plastic housing with surface resistance of less than < 10 ⁹ Ohm/cm						
5	Legs for control unit alu-tube 2 pieces				320		
6	Legs for control unit stainless steel-tube V2 A 2 pieces				600		
7	Reeling hooks for control unit stainless steel V2 A				1200		
8	Cable entry M 32 for cable 11-21 mm or M 40 for cable 19-28 mm				80		
9							
10	Multi-axis controller	see catalog 1/100					
11	Single-axis controller	see catalog 1/200					
12							
13	Control-switch	see catalog 1/220					
14	Command and indicating devices	see catalog 1/360					
15	Plug in socket 16-pole male insert	HAN 16 E without wiring			200		
16	Connector 16-pole female insert	HAN 16 E without wiring			250		
17	Plug in socket 24-pole male insert	HAN 24 E without wiring			320		
18	Connector 24-pole female insert	HAN 24 E without wiring			340		
19	Plug in socket 32-pole male insert	HAN 32 A without wiring			380		
20	Connector 32-pole female insert	HAN 32 A without wiring			400		
21	Cable Oelflex 18 x 1 mm ² 13,4 mm ø	-5° C to +80° C	each metre		320		
22	Cable Oelflex 25 x 1 mm ² 15,4 mm ø	-5° C to +80° C	each metre		450		
23	Cable Oelflex 34 x 1 mm ² 18,6 mm ø	-5° C to +80° C	each metre		600		
24	Cable Neoflex 18 x 1 mm ² 19,2 mm ø	-30° C to +80° C	each metre		470		
25	Cable Neoflex 24 x 1 mm ² 22,1 mm ø	-30° C to +80° C	each metre		650		
26	Cable Neoflex 36 x 1 mm ² 26,1 mm ø	-30° C to +80° C	each metre		910		
27							
30	Terminal block 2,5 mm ² without wiring each terminal					KL	
31	Terminal block 2,5 mm ² with wiring wire 1,5 mm ² each terminal					KL	
32	Wired plug in socket, connector or cable each wire terminal						
33							
34							
40	Indicating labels not engraved with 2 or 4 arrows						
41	Engraving, each 10 characters						



With chest plate and straps
Protection IP 65
with multi-axis controllers IP 54

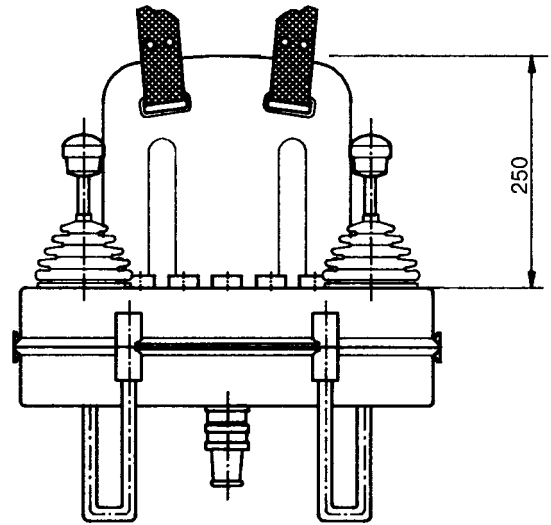
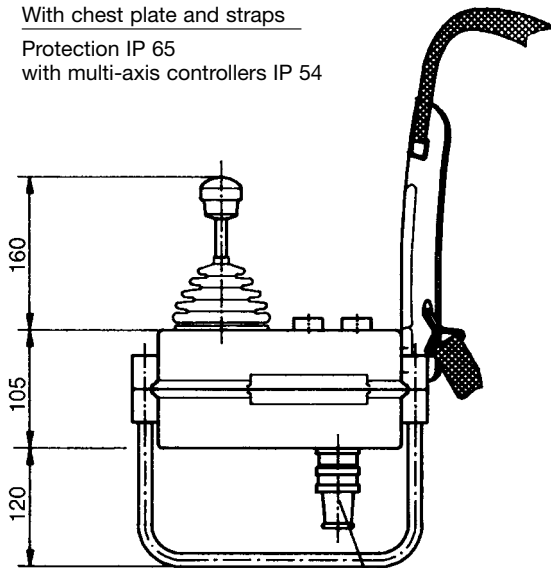

Cable entry
with anti-kink protection and
strain relief or connectors

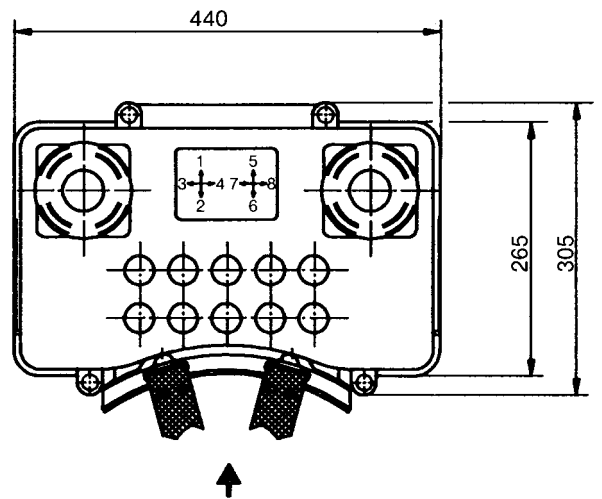

Direction of view

With adjustable carrying strap
Protection IP 65
with multi-axis controllers IP 54

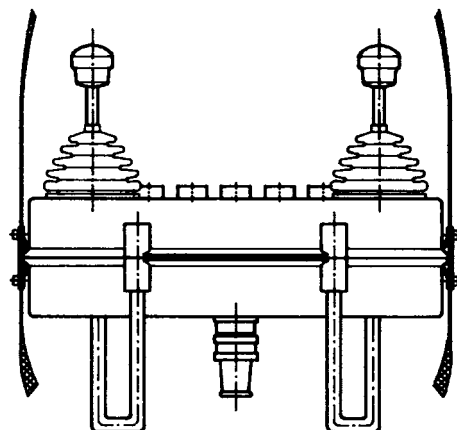
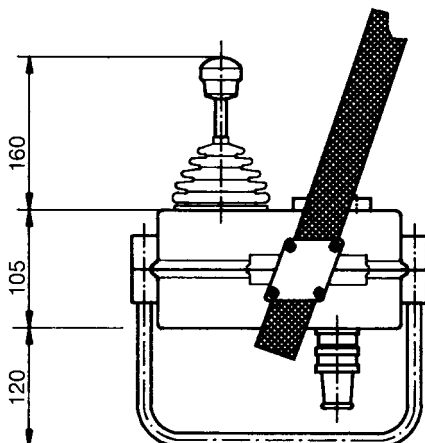



Type TS22-3-9-...

The portable control unit TS 2 accommodates all the devices necessary for control and monitoring. The chest panel and straps enable the operator to carry it without becoming tired. An adjustable carrying strap can also be fitted for use without the chest plate.

The control console is made of polyester (glass fibre reinforced plastic). Colour RAL 7032 pebble-grey. It can also be supplied as RAL 1021 yellow.

Permissible ambient temperature	Operation -40° C to +60° C
Climate resistance	Storage -50° C to +80° C
Damp heat constant	DIN IEC 68 part 2-3
Damp heat cyclic	DIN IEC 68 part 2-30
Degree of protection	control unit IP 65 with multi-axis controller IP 54 to IEC 529 DIN 40050

Pos.				Weight gramm	Type	Price EURO
1	Control unit with chest plate and straps			2400	TS 2	
2	Control unit with straps			2100	TS 21	
3	Control unit with bracket and straps			2400	TS 22	
4	Plastic housing with surface resistance of less than < 10 ⁹ Ohm/cm					
5	Legs for control unit alu-tube 2 pieces			320		
6	Legs for control unit stainless steel-tube V2 A 2 pieces			600		
7	Reeling hooks for control unit stainless steel V2 A			1200		
8	Cable entry M 32 for cable 11-21 mm or M 40 for cable 19-28 mm			80		
9	Cable entry 180° swivelling M 32 for cable 11-21 mm or M 40 for cable 19-28 mm			190		
10	Multi-axis controller	see catalog 1/100				
11	Single-axis controller	see catalog 1/200				
12						
13	Control-switch	see catalog 1/220				
14	Command and indicating devices	see catalog 1/360				
15	Plug in socket 16-pole male insert	HAN 16 E without wiring		200		
16	Connector 16-pole female insert	HAN 16 E without wiring		250		
17	Plug in socket 24-pole male insert	HAN 24 E without wiring		320		
18	Connector 24-pole female insert	HAN 24 E without wiring		340		
19	Plug in socket 32-pole male insert	HAN 32 E without wiring		380		
20	Connector 32-pole female insert	HAN 32 E without wiring		400		
21	Cable Oelflex 18 x 1 mm ² 13,4 mm ø	-5° C to +80° C	each metre	320		
22	Cable Oelflex 25 x 1 mm ² 15,4 mm ø	-5° C to +80° C	each metre	450		
23	Cable Oelflex 34 x 1 mm ² 18,6 mm ø	-5° C to +80° C	each metre	600		
24	Cable Neoflex 18 x 1 mm ² 19,2 mm ø	-30° C to +80° C	each metre	470		
25	Cable Neoflex 24 x 1 mm ² 22,1 mm ø	-30° C to +80° C	each metre	650		
26	Cable Neoflex 36 x 1 mm ² 26,1 mm ø	-30° C to +80° C	each metre	910		
27						
30	Terminal block 2,5 mm ² without wiring each terminal				KL	
31	Terminal block 2,5 mm ² with wiring wire 1,5 mm ² each terminal				KL	
32	Wired plug in socket, connector or cable each wire-connection					
33						
34						
40	Indicating labels not engraved with 2 or 4 arrows					
41	Engraving, each 10 characters					



With chest plate and straps
Protection IP 65
with multi-axis controllers IP 54

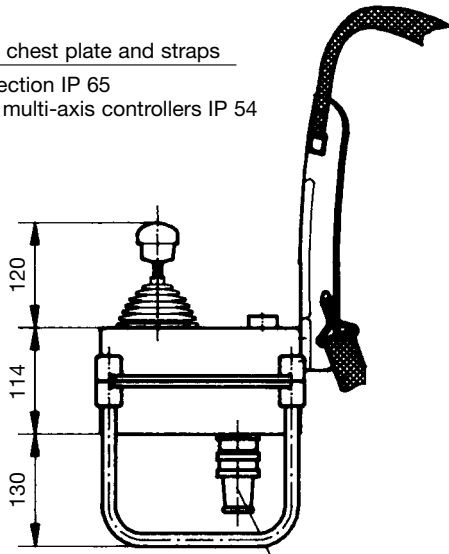

Cable entry
with anti-kink protection and
stain relief or connectors

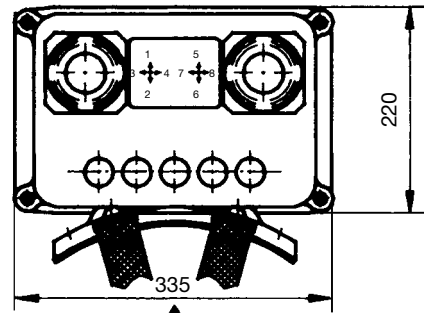
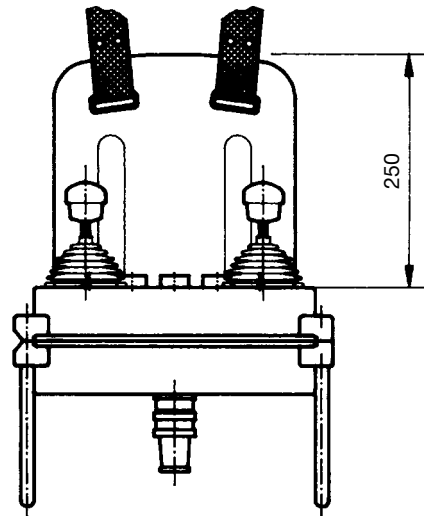

Direction of view

With adjustable carrying strap
Protection IP 65
with multi-axis controllers IP 54

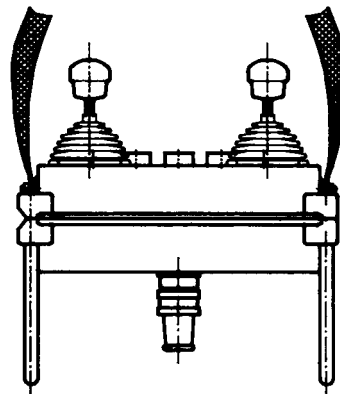
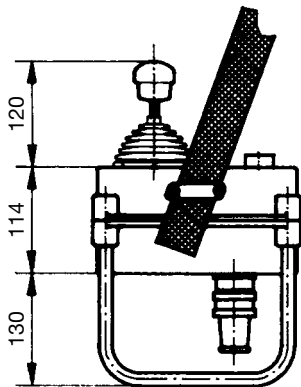

With bracket and cable entry swivelling
Protection IP 65 with multi-axis controllers IP 54

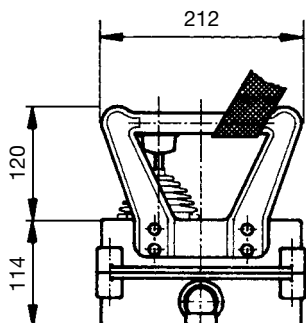

Cable entry 180°
swivelling
with anti-kink protection
and stain relief or connectors

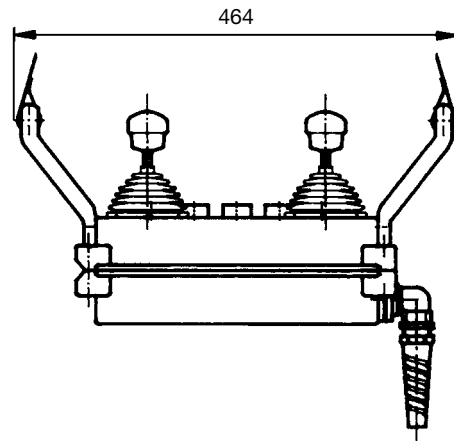

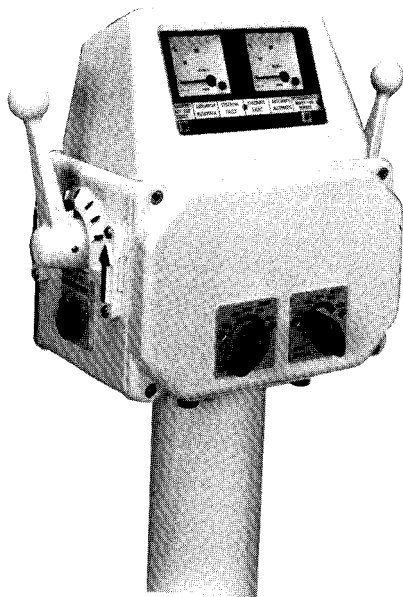

Type U22/32/FD/HD/IA/RS/-...

The control pedestal U 22/32 accommodates the devices necessary for control and monitoring.

Ready wired, it can be quickly and easily installed on the sea deck.
The housing (pedestal head) is made of seawater-resistant aluminium.

**Contact complement 2 A 250 V AC 15 res. 1 A 24 V DC 13 (standard)
or 4 A 250 V AC 15 (special)**

Surface treatment: Anti-corrosion primer, top coat: two coats of epoxy-resin paint, standard colour RAL 7032 pebble-grey textured varnish

All non-painted metal parts are electrogalvanized and chromed.
All mechanical operating parts are made of non-rusting materials.

Permissible ambient temperature Operation -40° C to +60° C
Storage -50° C to +80° C

Climate resistance
Damp heat constant DIN IEC 68 part 2-3
Damp heat cyclic DIN IEC 68 part 2-30
Degree of protection IP 66 IEC 529 DIN 40050

Pos.			Weight kp	Type	Price EURO
1	Housing U 22 / 32 with 1 narrow side-plate with pillar-gasket		6,8	U22/32	
2	Side-plate narrow gasket		1,8	FD	
3	Side-plate wide with gasket (required for command and indicating devices Pos. 22-26)		2,4	HD	
4	Hinged side-plate with gasket that can be locked in position (cover for command and indicating devices)		4,0	KD	
5	Monitoring devices cover with gasket for max. 2 monitors 72 x 72 mm or 4 monitors 72 x 36 mm and max. 6 indicating devices Pos. 28, 29		2,9	IA	
6	Pillar 108 mm ø 670 mm height with flange quadratic or round		18,8	RS	
10	Masterswitch with 6 contacts, with spring return in 0-position with ball handle and indicating labels drive		2,0	N61-03Z-HG	
11	Control-switches with 4 contacts with knob and indicating label		0,7	N62-02-KN ± 01	
12	Additional or subtract price each 2 contacts				
13	more variants see catalog 1/220				
14	Wire-wound potentiometer T 130 with centre tap linear life 10 ⁷ switching cycles resistance 2 x 0,5 / 1 / 2 / 5 / 10 kOhm 1,5 Watt wiper current max. 10 mA		0,07	P	
15	more potentiometer see catalog 1/240...				
16	Control-switch with 4 contacts with knob and indicating label	protection IP67	0,4	NWSE	
17	Additional or subtract price each 2 contacts				
20	Heating 20 Watt 220 or 110 V / 50/60 Hz		0,15	H	
21	Mushroom head push button latching 22 with indicating label	1 NC protection IP67	0,1	PV	
22	Mushroom head push button 22 with indicating label	1 NO protection IP67	0,1	P	
23	Push button 22 with indicating label	1 NO protection IP67	0,1	D	
24	Selector switch 22 with indicating label	1 NO protection IP67	0,1	W	
25	Indicator light 22 with indicating label	Diode 24 Volt protection IP67	0,1	L	
26	Indicator light 22 with indicating label	Diode 220 Volt AC protection IP67	0,1	L	
27	Contact block additional	1 NO or 1 NC			
28	Indicator light 22 with indicating label	24 Volt protection IP65	0,05	L	
29	Indicator light 10 with indicating label	Diode 24 Volt protection IP67	0,03	L	
35	Power monitoring PQ 72 1 mA DC	Engraved your instructions	0,2	PQ	
36	Power monitoring PQ 72 x 36 1 mA DC	Engraved your instructions	0,3	PQ	
37	Ampere monitoring EQ 72 100 / 200 / 1 A	Engraved your instructions	0,2	EQ	
38	Ampere monitoring EQ 72 x 36 100 / 200 / 1 A	Engraved your instructions	0,3	EQ	
39	Monitoring illuminated	24 Volt			
40	Another electrical value are available				
45	Terminal block 2,5 mm ² without wiring	each terminal		KL	
46	Terminal block 2,5 mm ² with wiring wire 0,75 mm ²	each terminal		KL	
47					
48					
49					
50	Engraving, each 10 characters				

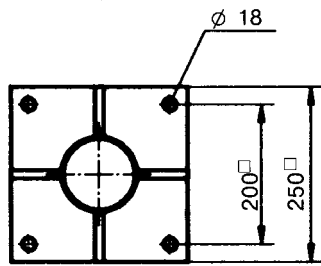
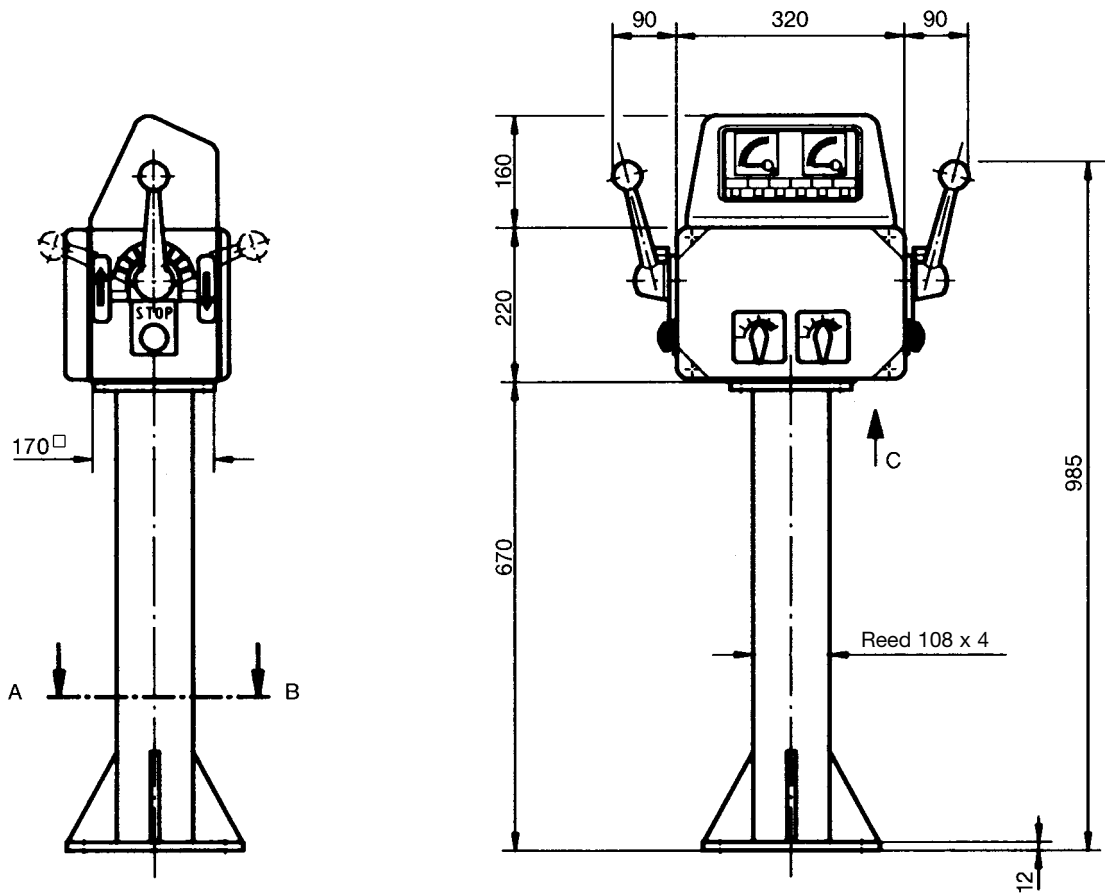

View A - B

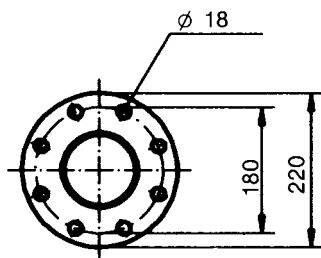
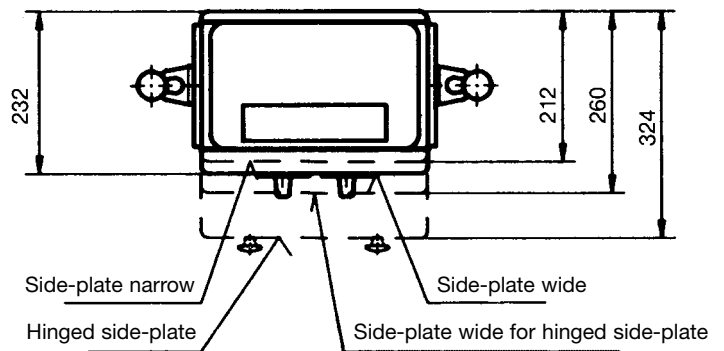

View A - B
(option flange NW 100, DIN 2633)

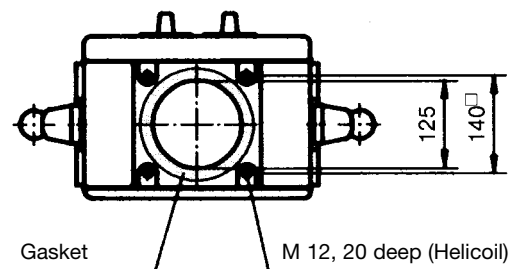

View C

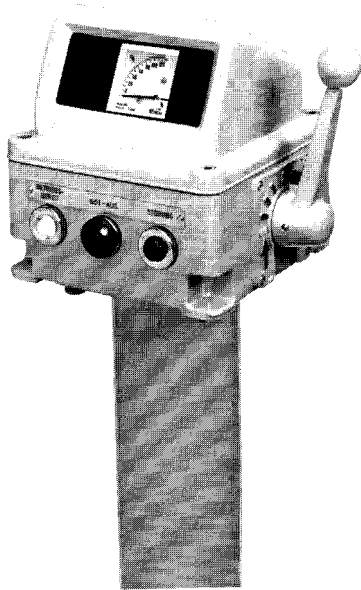

Type U23/23/1A/RS/...

The control pedestal U 23/23 accommodates the devices necessary for control and monitoring.

Ready wired, it can be quickly and easily installed on the sea deck.
The housing (pedestal head) is made of seawater-resistant aluminium.

**Contact complement 2 A 250 V AC 15 res. 1 A 24 V DC 13 (standard)
or 4 A 250 V AC 15 (special)**

Surface treatment: Anti-corrosion primer, top coat: two coats of epoxy-resin paint, standard colour RAL 7032 pebble-grey textured varnish

All non-painted metal parts are electrogalvanized and chromed.
All mechanical operating parts are made of non-rusting materials.

Permissible ambient temperature Operation -40° C to +60° C
Storage -50° C to +80° C

Climate resistance
Damp heat constant DIN IEC 68 part 2-3
Damp heat cyclic DIN IEC 68 part 2-30
Degree of protection IP 66 IEC 529 DIN 40050

Pos.			Weight kp	Type	Price EURO
1	Housing U 23 / 23 with 1 narrow cover with pillar-gasket		5,3	U23/23	
2	Housing U 23 / 23 with 1 narrow cover without thrilling in the housing		5,4	U23/23	
3					
4					
5	Monitoring devices cover with gasket for max. 2 monitors 72 x 72 mm or 1 monitors 72 x 72 mm and max. 6 indicating devices Pos. 28, 29		2,3	IA	
6	Pillar 108 mm ø 670 mm height with flange quadratic or round		18,8	RS	
10	Masterswitch with 6 contacts, with spring return in 0-position, with ball handle and indicating labels drive		2,0	N61-03Z-HG	
11	Control switches with 4 contacts with knob and indicating label		0,7	N62-02-KN	
12	Additional or subtract price each 2 contacts			± 01	
13	more variants see catalog 1/220				
14	Wire-wound potentiometer T 130 with centre tap linear life 10 ⁷ switching cycles resistance 2 x 0,5 / 1 / 2 / 5 / 10 kOhm 1,5 Watt wiper current max. 10 mA		0,07	P	
15	more potentiometer see catalog 1/240...				
16	Control-switch with 4 contacts with knob and indicating label	protection IP67	0,4	NWSE	
17	Additional or subtract price each 2 contacts				
20	Heating 20 Watt 220 V or 110 V / 50/60 Hz		0,15	H	
21	Mushroom head push button latching 22 with indicating label	1 NC protection IP67	0,1	PV	
22	Mushroom head push button 22 with indicating label	1 NO protection IP67	0,1	P	
23	Push button 22 with indicating label	1 NO protection IP67	0,1	D	
24	Selector switch 22 with indicating label	1 NO protection IP67	0,1	W	
25	Indicator light 22 with indicating label	Diode 24 Volt protection IP67	0,1	L	
26	Indicator light 22 with indicating label	Diode 220 Volt AC protection IP67	0,1	L	
27	Contact block additional	1 NO or 1 NC			
28	Indicator light 22 with indicating label	24 Volt protection IP65	0,05	L	
29	Indicator light 10 with indicating label	Diode 24 Volt protection IP67	0,03	L	
35	Power monitoring PQ 72 1 mA DC	Engraved your instructions	0,2	PQ	
36					
37	Ampere monitoring EQ 72 100 / 200 / 1 A	Engraved your instructions	0,2	EQ	
38					
39	Monitoring illuminated	24 Volt			
40	Another electrical value available				
45	Terminal block 2,5 mm ² without wiring	each terminal		KL	
46	Terminal block 2,5 mm ² with wiring wire 0,75 mm ²	each terminal		KL	
47					
48					
49					
50	Engraving, each 10 characters				

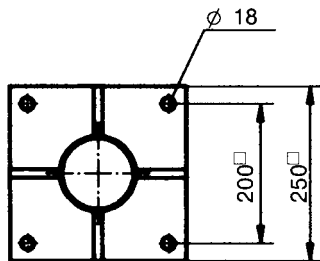
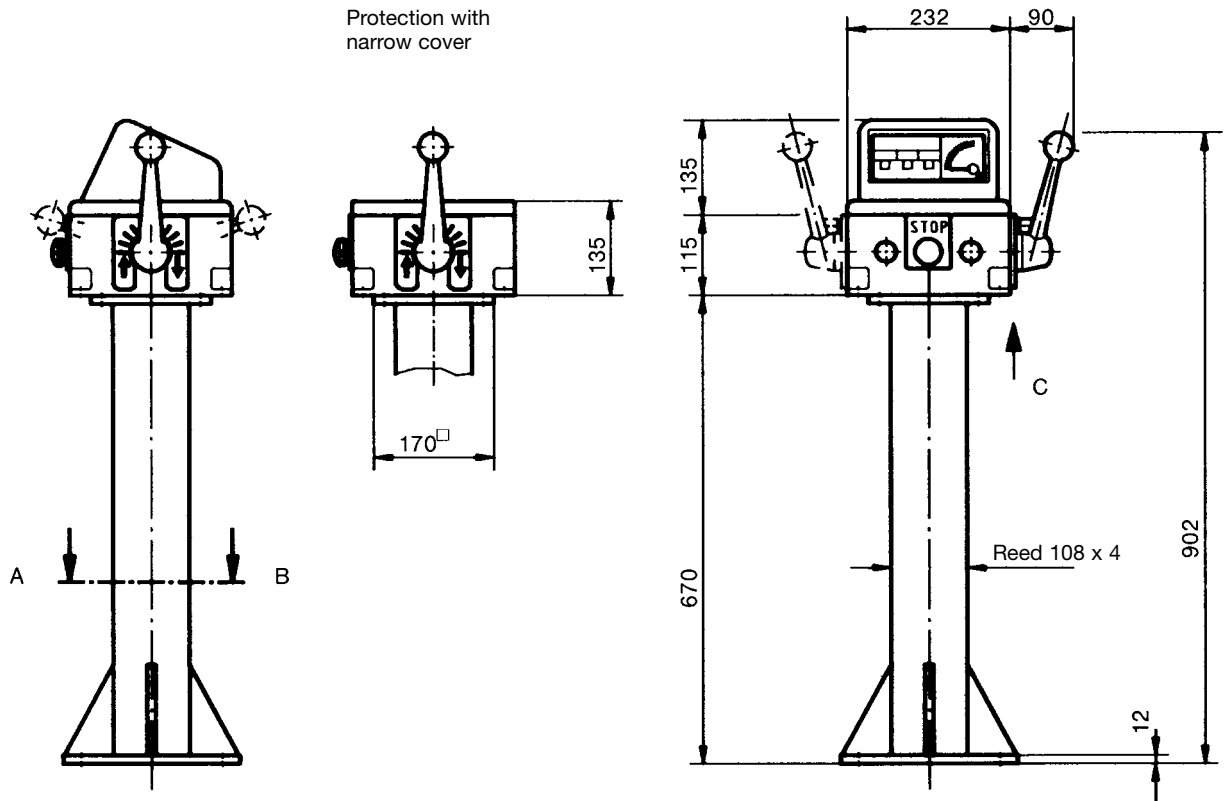

View A - B

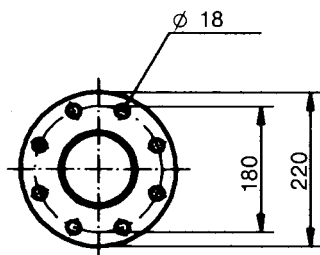

View A - B
(option flange NW 100, DIN 2633)

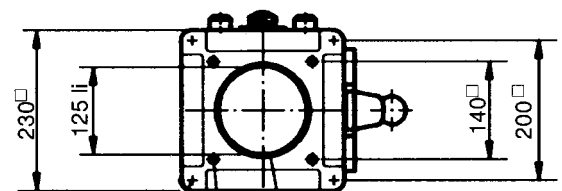

ø 9, mounting
at the top

M 12, 20 deep (Helicoil)
mounting at the bottom

View C



Type U25/32/1A/RS/...

The control pedestal U 25/32 accommodates the devices necessary for control and monitoring.

Ready wired, it can be quickly and easily installed on the sea deck.
The housing (pedestal head) is made of seawater-resistant aluminium.

**Contact complement 2 A 250 V AC 15 res. 1 A 24 V DC 13 (standard)
or 4 A 250 V AC 15 (special)**

Surface treatment: Anti-corrosion primer, top coat: two coats of epoxy-resin paint, standard colour RAL 7032 pebble-grey textured varnish

All non-painted metal parts are electrogalvanized and chromed.
All mechanical operating parts are made of non-rusting materials.

Permissible ambient temperature Operation -40° C to +60° C
Storage -50° C to +80° C

Climate resistance
Damp heat constant DIN IEC 68 part 2-3
Damp heat cyclic DIN IEC 68 part 2-30
Degree of protection IP 66 IEC 529 DIN 40050

Pos.			Weight kp	Type	Price EURO
1	Housing U 25 / 32 with 1 narrow side-plate with pillar-gasket		6,8	U25/32	
2					
3					
4					
5	Monitoring devices cover with gasket for max. 2 monitors 72 x 72 mm or 4 monitors 72 x 36 mm and max. 6 indicating devices Pos. 28, 29		2,9	IA	
6	Pillar 108 mm ø 670 mm height with flange quadratic or round		18,8	RS	
10	Masterswitch with 6 contacts, with spring return in 0-position with ball handle and indicating labels drive		2,0	N61-03Z-HG	
11	Control-switches with 4 contacts with knob and indicating label		0,7	N62-02-KN ± 01	
12	Additional or subtract price each 2 contacts				
13	more variants see catalog 1/220				
14	Conductive-plastic potentiometer T... with centre tap linear life 10 ⁷ switching cycles resistance 2 x 1 / 5 / 10 kOhm 0,5 Watt wiper current max. 1 mA more potentiometer see catalog 1/240...		0,07	P	
15	Control-switch with 4 contacts with knob and indicating label	protection IP67	0,4	NWSE	
16	Additional or subtract price each 2 contacts				
20	Heating 20 Watt 220 V or 110 V / 50/60 Hz		0,15	H	
21	Mushroom head push button latching 22 with indicating label	1 NC protection IP67	0,1	PV	
22	Mushroom head push button 22 with indicating label	1 NO protection IP67	0,1	P	
23	Push button 22 with indicating label	1 NO protection IP67	0,1	D	
24	Selector switch 22 with indicating label	1 NO protection IP67	0,1	W	
25	Indicator light 22 with indicating label	Diode 24 Volt protection IP67	0,1	L	
26	Indicator light 22 with indicating label	Diode 220 Volt AC protection IP67	0,1	L	
27	Contact block additional	1 NO or 1 NC			
28	Indicator light 22 with indicating label	24 Volt protection IP65	0,05	L	
29	Indicator light 10 with indicating label	Diode 24 Volt protection IP67	0,03	L	
35	Power monitoring PQ 72 1 mA DC	Engraved your instructions	0,2	PQ	
36	Power monitoring PQ 72 x 36 1 mA DC	Engraved your instructions	0,3	PQ	
37	Ampere monitoring EQ 72 100 / 200 / 1 A	Engraved your instructions	0,2	EQ	
38	Ampere monitoring EQ 72 x 36 100 / 200 / 1 A	Engraved your instructions	0,3	EQ	
39	Monitoring illuminated	24 Volt			
40	Another electrical value are available				
45	Terminal block 2,5 mm ² without wiring	each terminal		KL	
46	Terminal block 2,5 mm ² with wiring wire 0,75 mm ²	each terminal		KL	
47					
48					
49					
50	Engraving, each 10 characters				

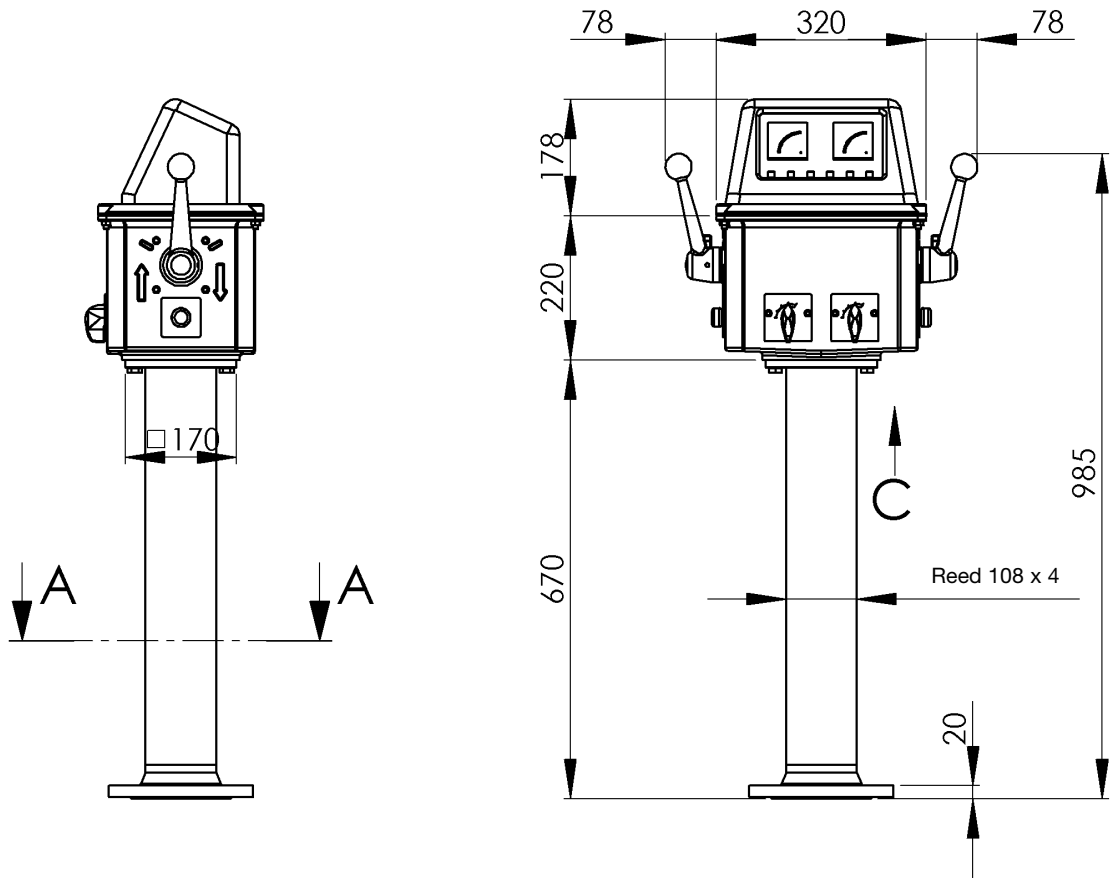

View A - A
Flange NW 100 DIN 2633

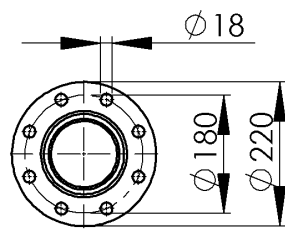

option flange 250 x 250

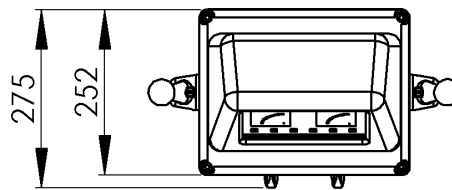
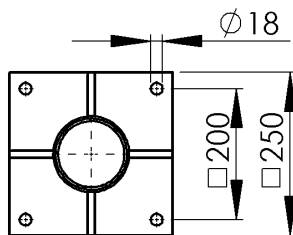

View C
(without pedestal)

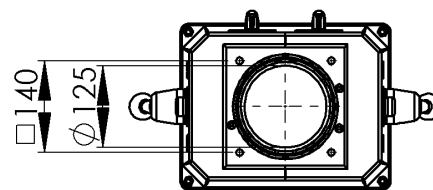

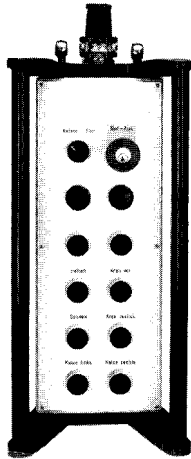

Type HT11...

The pedant control units HT 1 and HT 2 contain the control and monitoring devices.

The units are easy to grasp and are protected against damage and unintentional operation of the controls.

Cable entry has anti-kink protection and strain relief. The pedants are made of sheet steel.

Device arrangements:

HT 11	max. 12 command or indicating devices	double-row
HT 12	max. 16 command or indicating devices	double-row
HT 13	max. 20 command or indicating devices	double-row
HT 21	max. 32 command or indicating devices	four-row
HT 22	max. 40 command or indicating devices	four-row

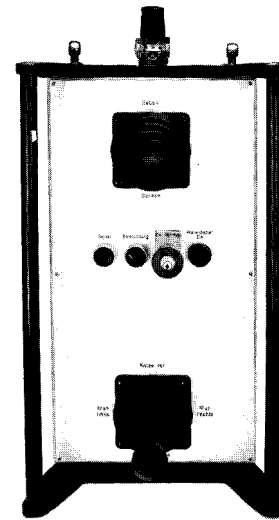

Type HT21...

The multi-axis controller V 11 with 2 x 6 contacts to take away the mounting positions of 6 command or indicating devices.

The multi-axis controller V 62 with 2 x 6 contacts to take away the mounting positions of 8 command or indicating devices.

Surface treatment: Anti-corrosion primer, top coat: 2 coats of epoxy-resin paint, standard colour RAL 7032 pebble-grey, textured varnish

Permissible ambient temperature Operation -40° C to +60° C
Storage -50° C to +80° C

Climate resistance
Damp heat constant DIN IEC 68 part 2-3
Damp heat cyclic DIN IEC 68 part 2-30
Degree of protection IP 54 IEC 529 DIN 40050

Pos.				Weight kp	Type	Price EURO
1	Pedant control unit	150 x 400 x 105 mm			HT 11	
2	Pedant control unit	150 x 500 x 105 mm			HT 12	
3	Pedant control unit	150 x 600 x 105 mm			HT 13	
4						
5	Pedant control unit	260 x 500 x 105 mm			HT 21	
6	Pedant control unit	260 x 600 x 105 mm			HT 22	
7						
8						
9						
10	Cable entry M 32 with anti-kink protection and strain relief	cable 11 – 21 mm				
11	Cable entry M 40 with anti-kink protection and strain relief	cable 19 – 28 mm				
13	Cable entry M 50 with anti-kink protection and strain relief	cable 27 – 35 mm				
14						
15	Multi-axis controller V 6 or V 11	see catalog 1/100	1/110			
16	Control-switch		see catalog 1/220			
17	Command and indicating devices		see catalog 1/360			
18						
19						
20	Terminal block 2,5 mm ² without wiring		each terminal		KL	
21	Terminal block 2,5 mm ² with wiring wire 1,5 mm ²		each terminal		KL	
22						
23						
24						
25	Eloxal aluminium front plate silvery for HT 1					
26	Eloxal aluminium front plate silvery for HT 2					
27	Indicating labels not engraved with 2 or 4 arrows					
28	Engraving, each 10 characters					



HT 1
Protection IP 54

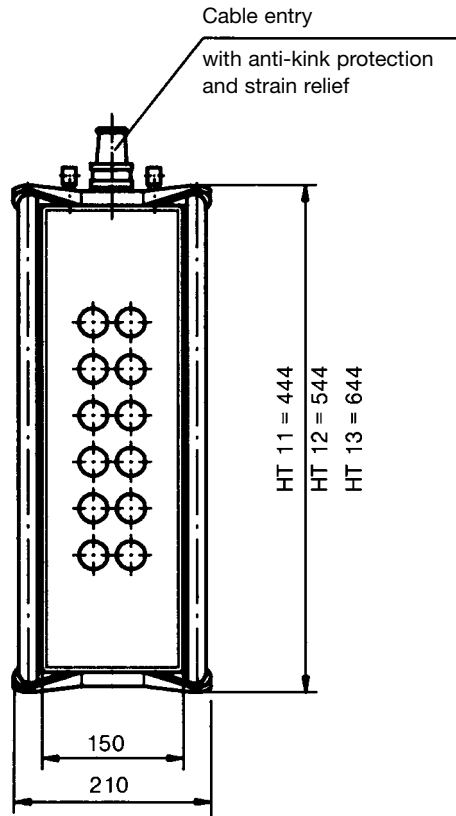

HT 11 = 400
HT 12 = 500
HT 13 = 600

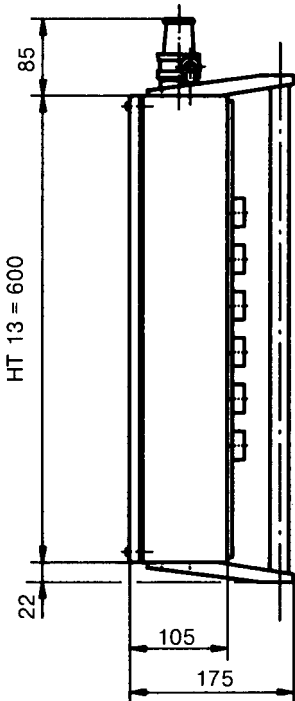

HT 2
Protection IP 54

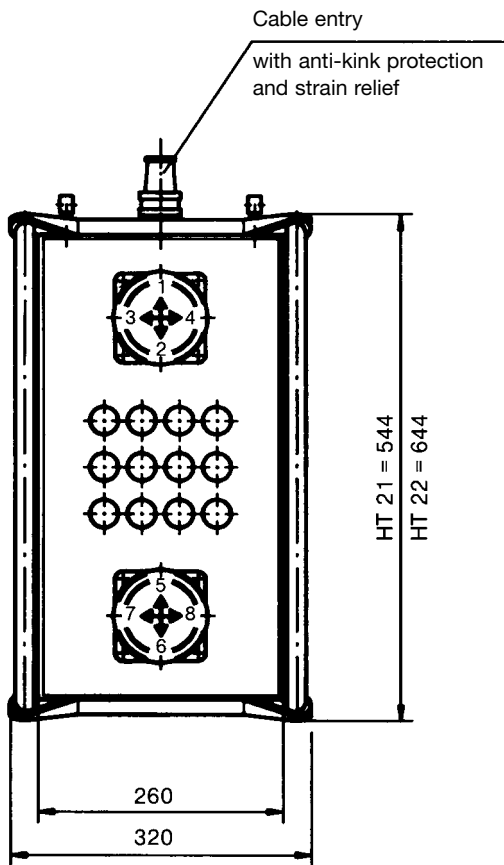

HT 21 = 500
HT 22 = 600

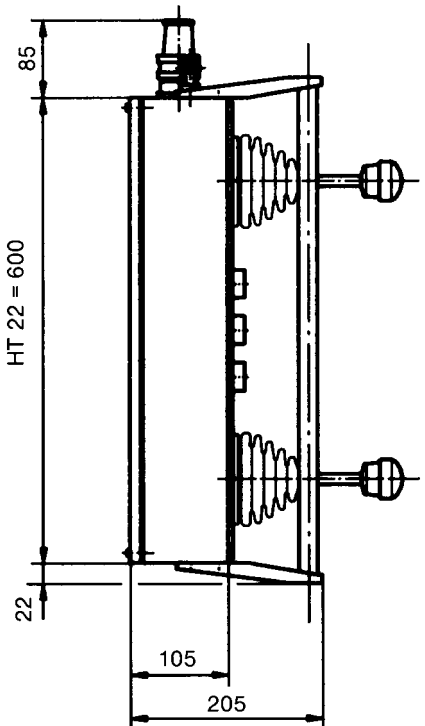

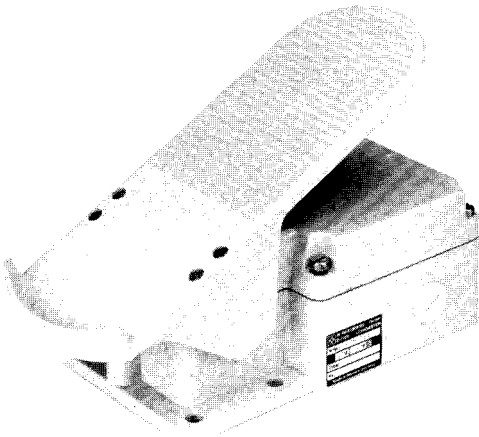

Type P7-1ZP-...

The pedal-controller P 7 and PP 7 is a rugged switching devices to IEC 947-5-1 EN 60 947 DIN VDE 0660-200, for footing applications.

Contact complement 2 A 250 V AC 15 res. 3 A 24 V DC 13

Surface treatment		Primer, top coat: 2 coats of epoxy-resin paint, standard colour RAL 7032 pebble-grey textured varnish
Mechanical life	P 7 PP 7	6 million operating cycles 10 million operating cycles
Permissible ambient temperature		Operation -40° C to +60° C Storage -50° C to +80° C
Climate resistance		DIN IEC 68 part 2-3
Damp heat constant		DIN IEC 68 part 2-30
Damp heat cyclic		IP 54 IEC 529 DIN 40050
Degree of protection	P 7 PP 7	IP 65 IEC 529 DIN 40050

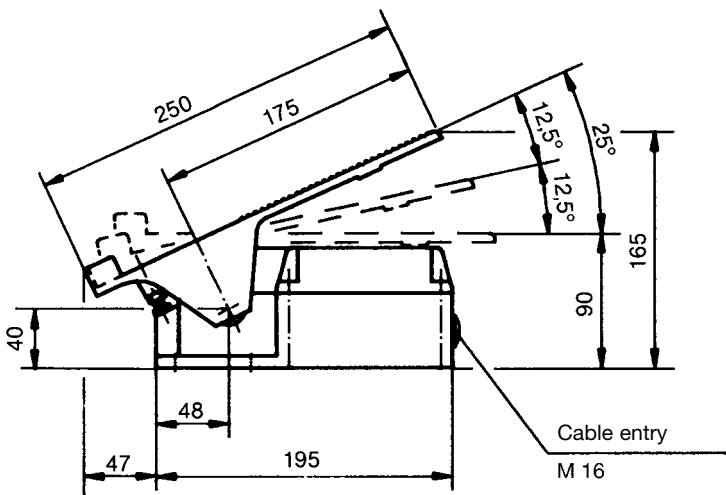

View at the top without rocker

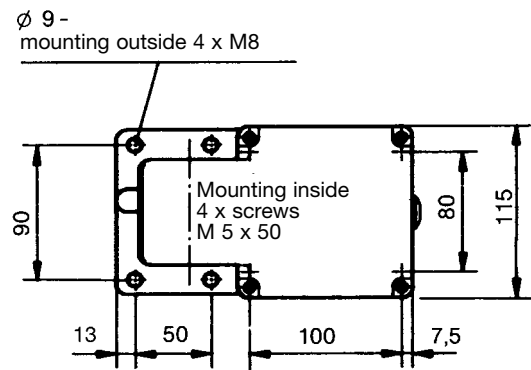

Example for type-sign

Pedal-controller
No. of contacts
Spring return

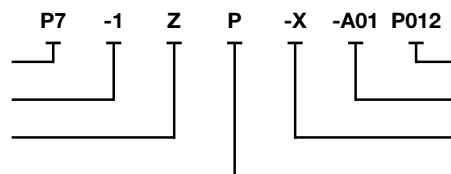

Potentiometer description
Arrangement
special please describe
Potentiometer e.t.c.

Pos.		Type-expansion	Weight gramm	Type	Price EURO
1	Pedal-controller standard version		1700	P 7	
2	Pedal-controller heavy-duty version		1800	PP 7	
4	Switching sequence max. 0-4 or max. 2-0-2		150		
8	No. of contacts (microswitch) max. 6 pcs.		30	1	
9	Switching program according contact-arrangement MS look catalog 5/001 or to your contact-arrangement	A...	40	2	
10			50	3	
11	Spring return in 0-position		100	Z	
12	Friction brake		50	R	
15	Potentiometer e.t.c. with mounted Wire-wound potentiometer T 129 linear 1,5 Watt wiper current max. 10 mA resistance 1k \triangleq P012, 2k \triangleq P013, 4k \triangleq P014, 10k \triangleq P015	P01 \square	70	P	
16	Prepared for mounting potentiometer shaft 6 mm adjusting-angel 300°			(P)	
17	More potentiometer e.t.c. look catalog 1/240...	P...			

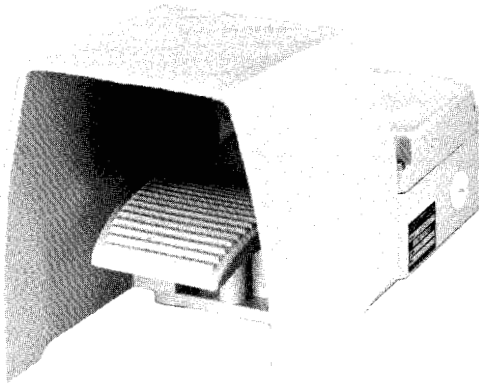

Type P8-1ZP-...

The pedal-controller P 8 and PP 8 is a rugged switching devices to IEC 947-5-1 EN 60 947 DIN VDE 0660-200, for footing applications.

Contact complement 2 A 250 V AC 15 res. 3 A 24 V DC 13

Surface treatment: Primer, top coat: 2 coats of epoxy-resin paint, standard colour RAL 7032 pebble-grey textured varnish

Mechanical life P 8 6 million (operating cycles)
PP 8 10 million (operating cycles)

Permissible ambient temperature Operation -40° C to +60° C
Storage -50° C to +80° C

Climate resistance
Damp heat constant DIN IEC 68 part 2-3
Damp heat cyclic DIN IEC 68 part 2-30
Degree of protection P 8 IP 54 IEC 529 DIN 40050
PP 8 IP 65 IEC 529 DIN 40050

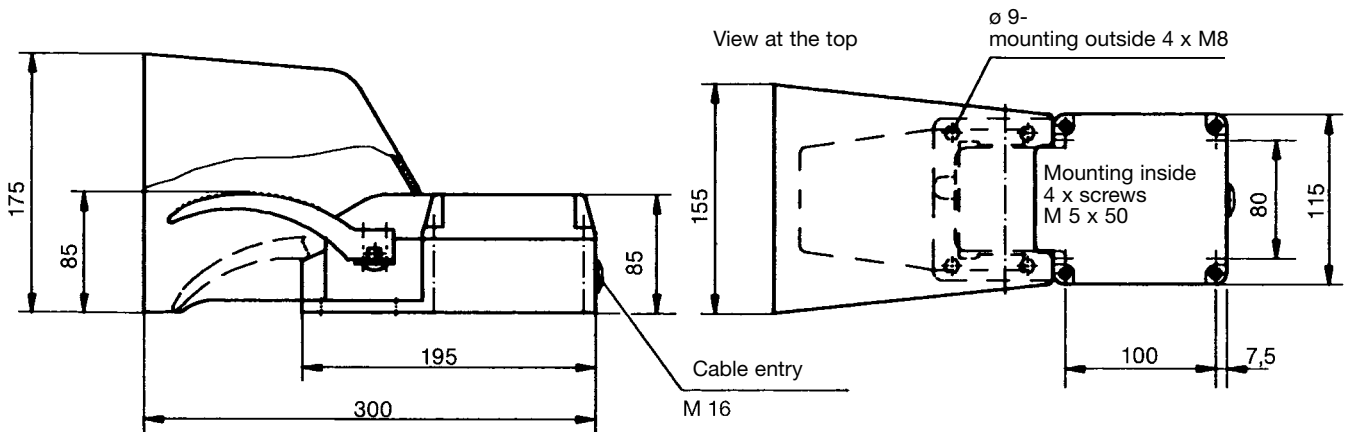

Example for type-sign

Pedal-controller

No. of contacts

Spring return

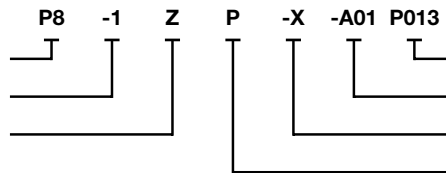

Potentiometer description

Arrangement

special please describe

Potentiometer e.t.c.

Pos.		Type-expansion	Weight gramm	Type	Price EURO
1	Pedal-controller standard version		2500	P 8	
2	Pedal-controller heavy-duty version		2600	PP 8	
4	Switching sequence max. 0-4		150		
8	No. of contacts (microswitch) max. 6 pcs.		30	1	
9	Switching program according contact-arrangement MS look catalog 5/001	A...	40	2	
10	or to your contact-arrangement		50	3	
11	Spring return in 0-position		100	Z	
12	Friction brake adjustable		50	R	
15	Potentiometer e.t.c. with mounted Wire-wound potentiometer T 129 linear 1,5 Watt wiper current max. 10 mA resistance 1k \triangleq P012, 2k \triangleq P013, 4k \triangleq P014, 10k \triangleq P015	P01 \square	70	P	
16	Prepared for mounting potentiometer shaft 6 mm adjusting-angle 300°			(P)	
17	More potentiometer e.t.c. look catalog 1/240...	P...			

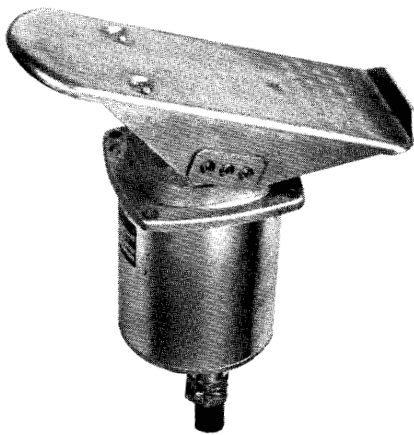

Type P10-1ZP-B...

The pedal-controller P 10 / P 11 is a rugged switching device to IEC 947-5-1 EN 60947 DIN VDE 0660-200 for electro-hydraulic applications. The modular design enables the switching device to be used universally. The P 10 / P 11 is resistant to oil, maritime climate, ozone and UV radiation.

**Contact complement 0,5 A 110 V AC 15 res. 1,5 A 24 V DC 13
I min > 0,2 mA 2 V DC 12 Gold plated for max. load of 0,12 Watt (standard)**

Mechanical life	8 million (operating cycles)
Permissible ambient temperature	Operation -40° C to +60° C Storage -50° C to +80° C
Climate resistance	
Damp heat constant	DIN IEC 68 part 2-3
Damp heat cyclic	DIN IEC 68 part 2-30
Degree of protection front	IP 54 IEC 529 DIN 40050

Technical data look catalog 5/100

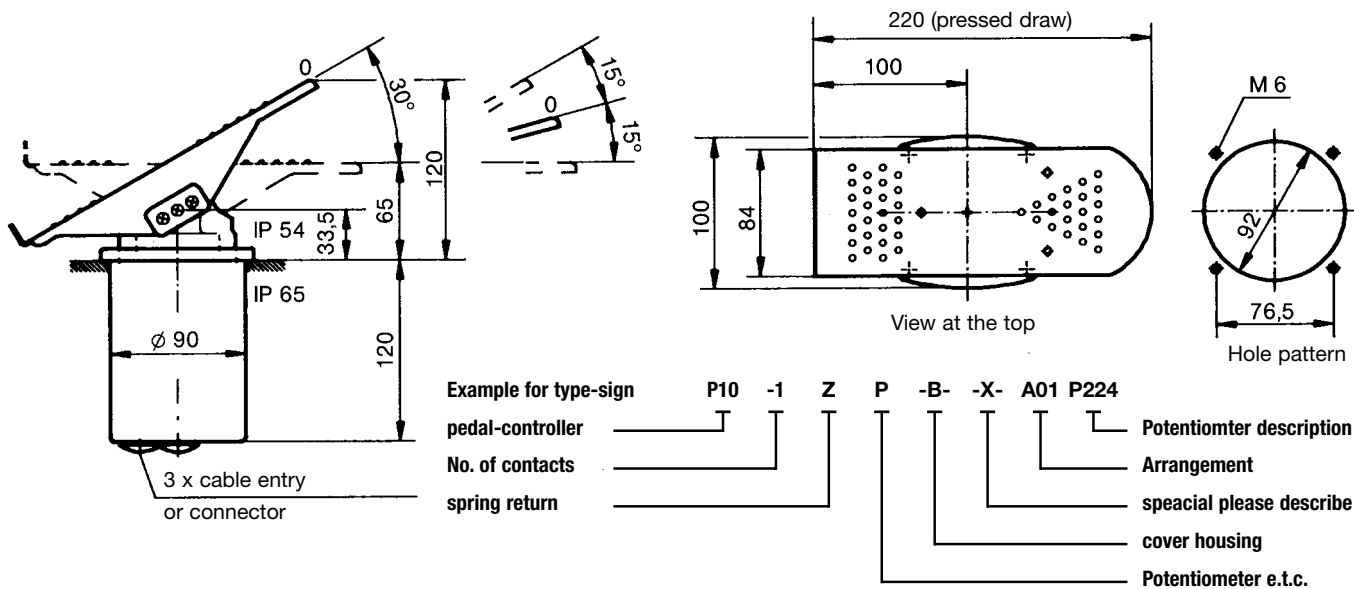

Pos.		Type-expansion	Weight gramm	Type	Price EURO
1	Pedal-controller standard version		1300	P 10	
2	Pedal-controller centre position notching max. 1-0-1		1300	P 11	
3	Switching sequence max. 0-3				
7	No. of contacts (microswitch) max. 3 pcs.		20	1	
8	Switching program according contact-arrangement MS look catalog 5/001	A...	40	2	
9	or to your contact-arrangement		60	3	
11	Spring return in 0-position		30	Z	
12	Friction brake adjustable		30	R	
15	Potentiometer e.t.c. with mounted Conductive-plastic potentiometer T 362 linear with centre tap life 10 ⁷ switching cycles Resistance 2 x 5 kOhm 0,5 Watt wiper current max. 1 mA	P224 □	70	P	
16	Prepared for mounting potentiometershaft 6 mm adjusting angle 120°	P...		(P)	
17	More potentiometer e.t.c. look catalog 1/240...				
18	Impedance converter Input ± 15 Volt, output ± 10 Volt / 5 mA	I...		I	
20	Cover housing		300	B	
21	Filter plug M 20 for air-condition		20		
22	Cable entry M 20		30		
23	Plug in socket 14-pole female insert CPC 17 wired		150		
24	Connector 14-pole male insert CPC 17 unwired		150		
25	Wiring plug in socket or connector each wired-connection				
26	Electronic (Amplifier, Profi-Bus, CAN-Bus) look catalog 3/510/...	E...			

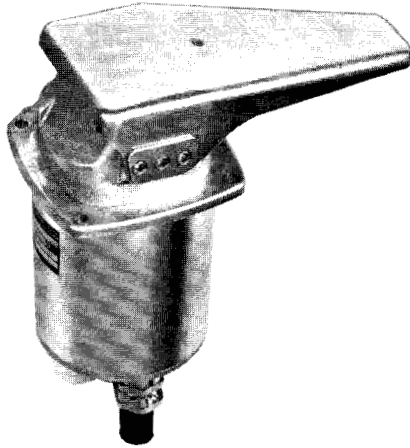

Type P12-1ZP-B...

The pedal-controller P 12 is a rugged switching device to IEC 947-5-1 EN 60947 DIN VDE 0660-200 for electro-hydraulic applications. The modular design enables the switching device to be used universally. The P 12 is resistant to oil, maritime climate, ozone and UV radiation.

Contact complement 0,5 A 110 V AC 15 res. 1,5 A 24 V DC 13
I min > 0,2 mA 2 V DC 12 Gold plated for max. load of 0,12 Watt (standard)

Mechanical life	8 million (operating cycles)
Permissible ambient temperature	Operation -40° C to +60° C Storage -50° C to +80° C
Climate resistance	
Damp heat constant	DIN IEC 68 part 2-3
Damp heat cyclic	DIN IEC 68 part 2-30
Degree of protection front	IP 54 IEC 529 DIN 40050

Technical data look catalog 5/100

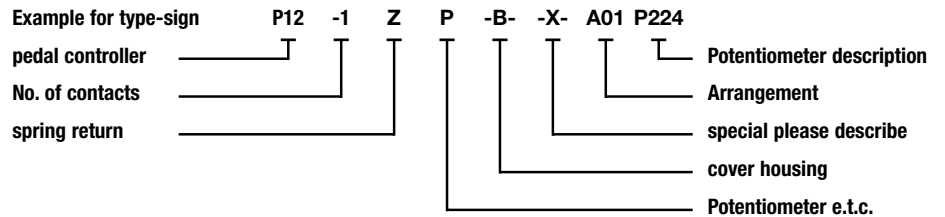
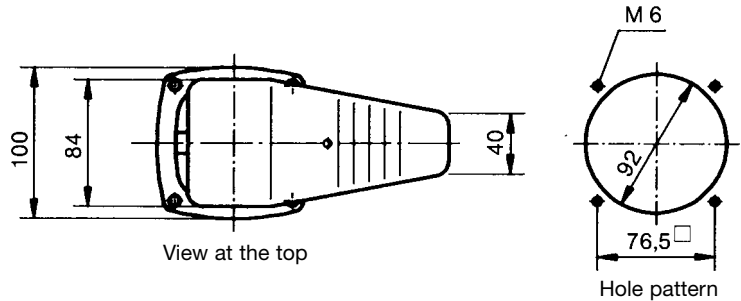
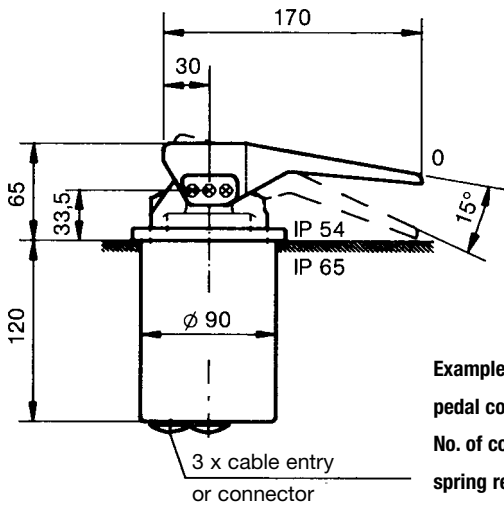

Pos.		Type-expansion	Weight gramm	Type	Price EURO
1	Pedal-controller standard version		1300	P 12	
2					
3	Switching sequence max. 0-3				
7	No. of contacts (microswitch) max. 3 pcs.		20	1	
8	Switching program according contact-arrangement MS look catalog 5/001	A...	40	2	
9	or to your contact-arrangement		60	3	
11	Spring return in 0-position		30	Z	
12	Friction brake adjustable		30	R	
15	Potentiometer e.t.c. with mounted Conductive-plastic potentiometer T 362 linear life 10 ⁷ switching cycles Resistance 5 kOhm 0,5 Watt wiper current max. 1 mA	P224 □	70	P	
16	Prepared for mounting potentiometershaft 6 mm adjusting angle 120°			(P)	
17	More potentiometer e.t.c. look catalog 1/240...	P...			
18	Impedance converter Input + 15 Volt, output + 10 Volt / 5 mA	I...		I	
20	Cover housing		300	B	
21	Filter plug M 20 for air-condition		20		
22	Cable entry M 20 with anti-kink protection and strain relief		30		
23	Plug in socket 14-pole female insert CPC 17 wired		150		
24	Connector 14-pole male insert CPC 17 unwired		150		
25	Wiring plug in socket or connector each wired-connection				
26	Electronic (Amplifier, Profi-Bus, CAN-Bus) look catalog 3/510/...	E...			

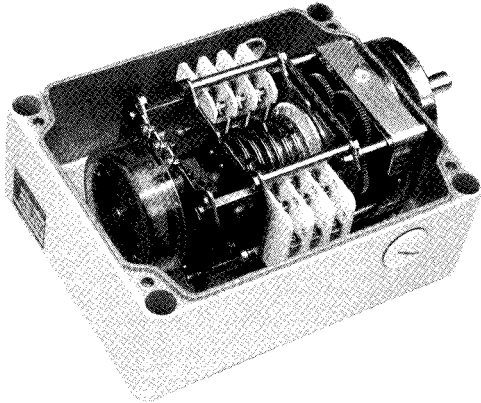

Type GE1-40-6P-U...

The gearing limit switch GE 1 / GE 2 is a rugged switching device to IEC 947-5-1 EN 60947 DIN VDE 0660-200 designed for hoisting applications. The modular micro changeover contacts are positive opening to VDE 0113.

Contact complement 2 A 250 V AC 15 res. 3 A 24 V DC 13

The device is programmed by means of stepless adjustment of double cam disks, which can be provided from 18° to 192° contact disks according to the switching program required.

The type GE 1 includes a double cam disk conjointly lockable.
The type GE 2 includes a double cam disk individually lockable.

The following gear ratios (n:1) are possible:
from 2 to 320
Further ratios can be provided as required.
The maximum usable rotational angle at the spindle is 342°.

Surface treatment	Primer, top coat: 2 coats of epoxy-resin paint, standard colour RAL 7032 pebble-grey textured varnish
Mechanical life	10 million (operating cycles)
Permissible ambient temperature	Operation -40° C to +60° C Storage -50° C to +80° C
Climate resistance	
Damp heat constant	DIN IEC 68 part 2-3
Damp heat cyclic	DIN IEC 68 part 2-30
Degree of protection (in housing)	IP 65 IEC 529 DIN 40050

Technical data look catalog 5/100, GE 1 T 576, GE 2 T 577

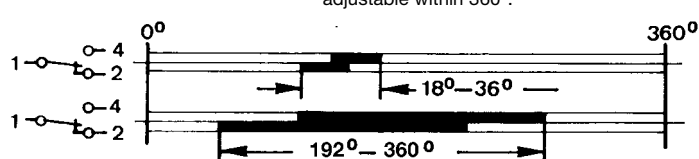
Pos.	Type-expansion	Weight gramm	Type	Price EURO	
1	Limit switch without gear Switching program with 18°, 24°, 30°, 36°, 45°, 60°, 75°, 90°, 110°, 120°, 176° or 192° contact ways program-disks (please select) The program-disks are infinitely adjustable within 360°. 	No. of contacts 2	350	2	
2		3	400	3	
3		4	450	4	
4		5	500	5	
5		6	550	6	
6		7	600	7	
7		8	650	8	
8		9	700	9	
9		10	750	10	
10		11	800	11	
11		12	850	12	
12		13	900	13	
13		14	950	14	
14		15	1000	15	
15		16	1050	16	
16		Double cam disk individually lockable GE 2	1		
18	Gearing Ratios (n : 1) 2 : 1 to 10 : 1 11 : 1 to 20 : 1 21 : 1 to 40 : 1 41 : 1 to 80 : 1 81 : 1 to 160 : 1 161 : 1 to 320 : 1 or ratios to your instructions		400		
19			450		
20			500		
21			550		
22			600		
23			650		
24					
25	Potentiometer e.t.c. with mounted Wire-wound potentiometer PW 70 d linear, 5 Watt wiper current max. 30 mA resistance 1k \triangleq P992, 2k \triangleq P993, 5k \triangleq P994, 10k \triangleq P995	P99 <input type="checkbox"/>	100	P	
26	Prepared for mounting potentiometer (gearing metal)			(P)	
27	Prepared for mounting potentiometer e.t.c. adjusting angle variable More potentiometer e.t.c. look catalog 1/240...	P...		(P)	
30	Aluminium housing U 17 / 13 for max. 8 contacts GE 1		1500	U5	
31	Aluminium housing U 16 / 16 for max. 12 contacts GE 1 , max. 6 contacts GE 2		2000	U6	
32	Aluminium housing U 16 / 20 for max. 16 contacts GE 1 , max. 10 contacts GE 2		2500	U7	
33	Aluminium housing U 16 / 26 for max 16 contacts GE 1		3000	U8	
34	Aluminium housing U 16 / 35		3500	U9	



View without build-on flange

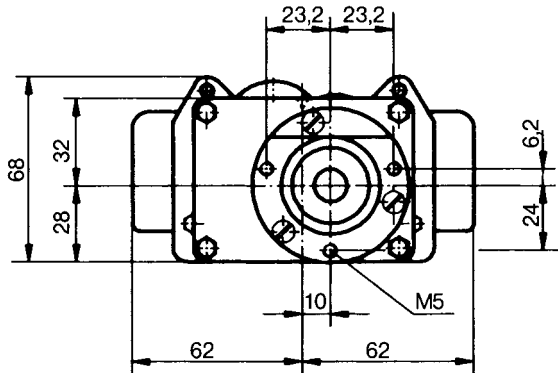

Protection IP 65

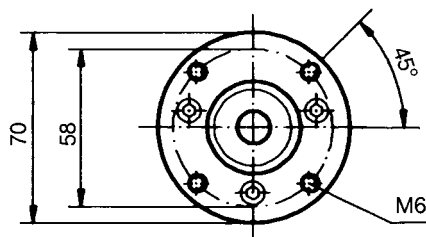
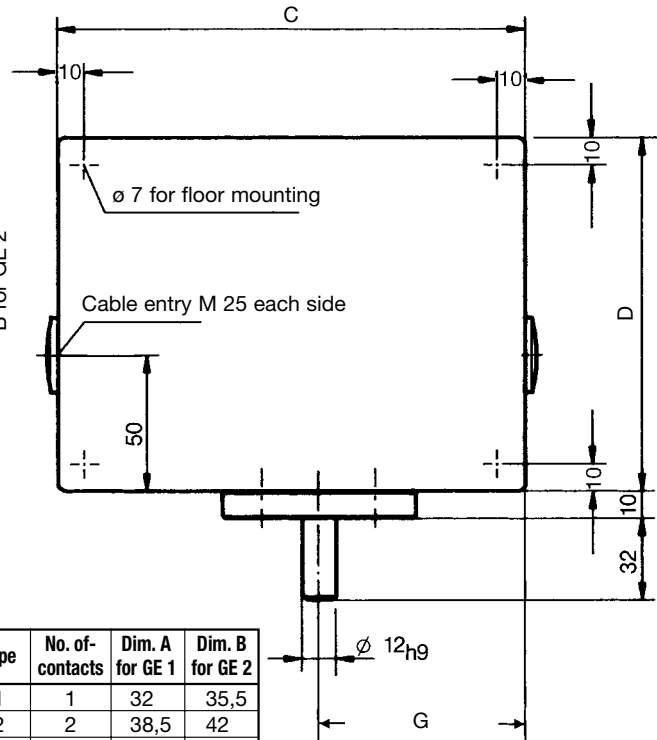
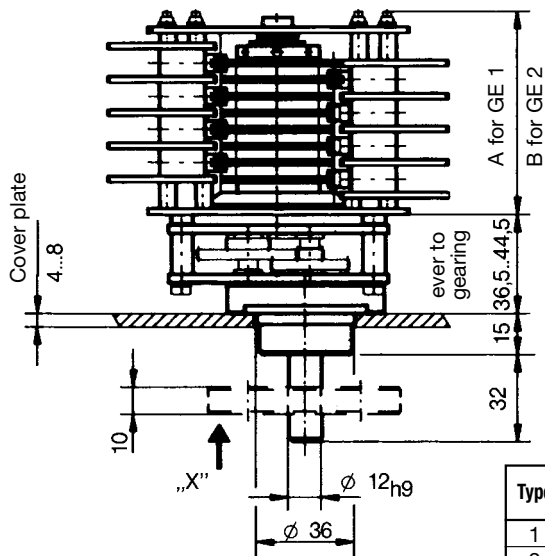
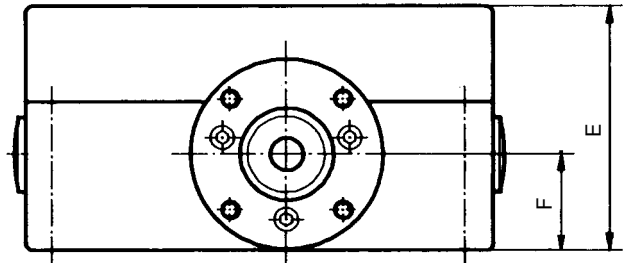

Build-on flange, view „X“

Type	No. of contacts	Dim. A for GE 1	Dim. B for GE 2
1	1	32	35,5
2	2	38,5	42
3	3	44,5	48
4	4	50,5	54
5	5	56,5	60
6	6	63	66,5
7	7	69	72,5
8	8	75	78,5
9	9	81	84,5
10	10	87	90,5
11	11	93	96,5
12	12	99	102,5
13	13	105,5	109
14	14	111,5	115
15	15	117,5	121
16	16	123,5	127

Type	Dim. C	Dim. D	Dim. E	Dim. F	Dim. G
U17/13	170	130	90	35,5	75
U16/16	160	160	91	45	70
U16/20	160	200	100	45	70
U16/26	160	260	91	45	70
U16/35	160	350	100	45	70

Example for type-sign

gear limit switch

gear ratios

No. of contacts

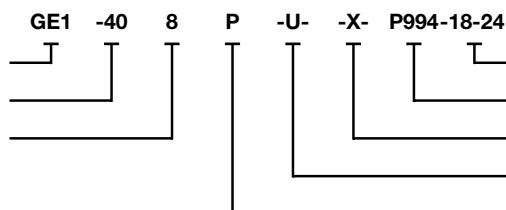

program-disk contact 1, 2...

Potentiometer description

special please describe

aluminium housing

Potentiometer e.t.c.

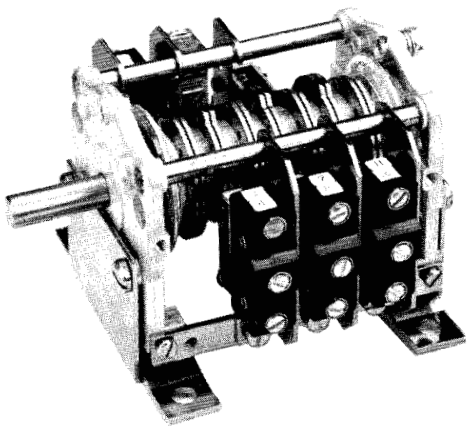

Type KVS-03-...

The copy-cam controller KVS is a rugged switching device to IEC 947-5-1 EN 60947 DIN VDE 0660-200 and is designed for packing machines. The free spindle end is intended for a gearwheel, sprocket wheel or for direct coupling to the driven machine. Gearing for matching rotational speed can be supplied (see 3/200).

The work sequence of the machine is "copied". The drum controller is supported in a bearing, is extremely accurate and has a long service life. The contact blocks, micro-switches, proximity initiators (items 15-19) can be replaced individually or can be combined.

The unit is programmed via double cam disks which can be adjusted steplessly and which have a 180° contact deck.

Surface treatment	Primer, top coat: 2 coats of epoxy-resin paint, standard colour RAL 7032 pebble-grey textured varnish
Mechanical life	20 million (operating cycles)
Permissible ambient temperature	Operation -40° C to +60° C Storage -50° C to +80° C

Climate resistance	DIN IEC 68 part 2-3
Damp heat constant	DIN IEC 68 part 2-30
Damp heat cyclic	IP 65 IEC 529 DIN 40050
Degree of protection (in housing)	

Technical data look catalog 5/100, T 104

Proximity initiator	
Type IN 5002-FPKG plus switching	
Type IN 5002-FNKG minus switching	
Connection voltage	18-30 V DC
Current loading	100 mA
Current consumption, not switched	10 mA
Ambient temperature, compensated	-25° C/+80° C
Output: contact-free, short-circuit proof and protected against polarity reversal, switching state displayed via LED	

Pos.				Weight kp	Type	Price EURO
1	Copy-cam controller		No. of contacts 3	0,7	01	
2	with free shaft end 12 mm ø		5	0,9	02	
3	without contacts		7	1,1	03	
4	without proximity initiator		9	1,3	04	
5			11	1,5	05	
6	Switching program 180° each contact way		13	1,7	06	
7			15	1,9	07	
8		The program-disks are infinitely adjustable within 360°.	17	2,1	08	
9			19	2,3	09	
10			21	2,5	10	
11			23	2,7	11	
12						
15	Cam operated switch 4 A 350 V AC 15	1 NC	1	0,08	5	
16						
17	Microswitch 8 A 250 V AC 15	1 NC + 1 NO	1	0,08	7	
18	Proximity initiator plus switching	1 NC or 1 NO	1	0,08	8	
19	Proximity initiator minus switching	1 NC or 1 NO	1	0,08	8	
20	Impulse device hall generator 15 Imp./rev via slot disk			0,08	I	
25	Second, free shaftend 12 mm ø				F	
26	Mounting angles 2 pieces each copy-cam controller			0,1	W	
30	Aluminium housing U 15 / 14 IP 54 up to type 03			1,7	U1	
31						
32	Aluminium housing U 15 / 30 IP 54 up to type 11			2,9	U3	

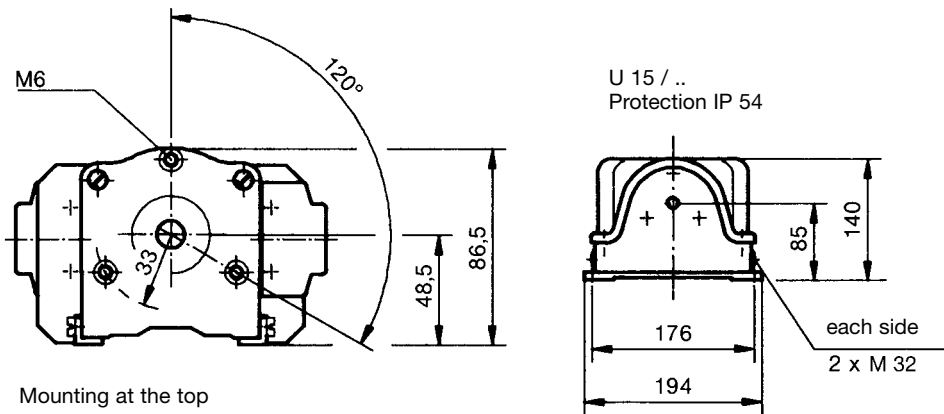

Mounting at the top

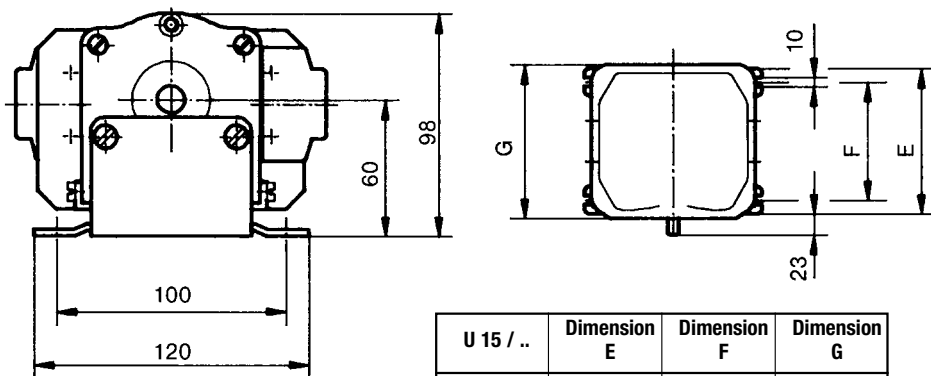

Mounting at the bottom
(with mounting angles)

U 15 / ..	Dimension E	Dimension F	Dimension G
/14	160	130	169
/30	320	290	329

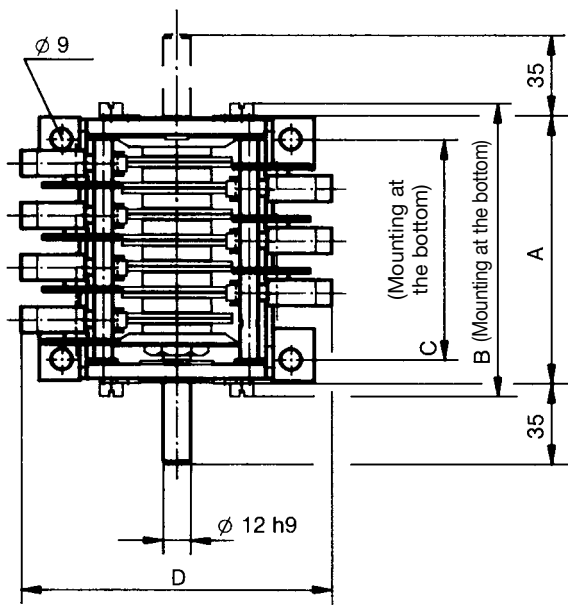

Type	No. of contact	Dimension A	Dimension B	Dimension C
01	3	72	87	51
02	5	95	110	74
03	7	118	133	97
04	9	141	156	120
05	11	164	180	143
06	13	187	202	166
07	15	210	225	189
08	17	233	248	212
09	19	256	271	235
10	21	279	294	258
11	23	302	317	281

Type	Dimension D	Screw-connection
KVS 5	125	M 4
KVS 7	145	M 3
KVS 8	140	M 3

Example for type-sign
Copy-cam controller
No. of contacts
Contact-type

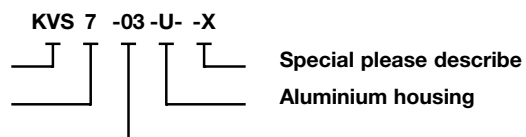

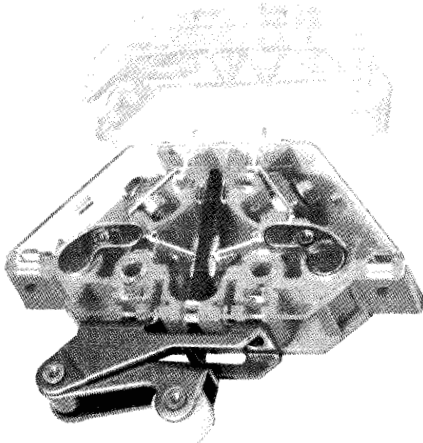

Type SO1.10-R-...

The DC contact block to IEC 947-5-1 EN 60947 DIN VDE 0660-200 and VDE 0670/4 § 20 is used for signalling and announcement applications. The snap-action mechanism prevents slow contact opening when the plunger is operated slowly. Quenching of the arc that occurs with DC is supported by two-capacity permanent magnets. These are arranged so that the polarity can be ignored when connecting +/- cabling.

However, the polarity of the quenching magnets must be noted when installing the contact blocks to prevent the magnets adversely affecting each other. Contact blocks in four different colours are available for polarity identification of the magnets when fitted (see diagram below left).

The contact blocks may only be installed on non-magnetizable materials with screws, etc. made of non-ferrous metal. The self-cleaning silver contacts are designed for low switching frequency, low currents and voltages. Gold coated contacts can be supplied (approx. 0,2 µ, less than 42 Volt required). The screw connection M3.5 at the side is suitable for 2 conductors max. 2.5 mm². The plug-in connection at the top 4.8 x 0.8 mm DIN 46247.

Several contact blocks can be plugged on top of each other and operated jointly. The plug-type terminals are then only accessible on the top unit. The contact blocks can be provided with shock protection to DIN VDE 0106 Part 100.

Please consult our technical department in the event of: application in extreme nuisance, confined switching points or increased breaking currents.

blue grey blue
green yellow green

———— Normally closed (NC)
———— Normally open (NO)

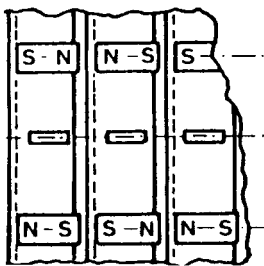

Unless otherwise requested, equal quantities grey/blue or yellow/green will be supplied.

Switching capacity

	NC	NO	Time constant
250 V DC	2 A	1 A	20 ms
125 V DC	4 A	3 A	20 ms
50 V DC	6 A	6 A	20 ms
30 V DC	10 A	10 A	20 ms
250 V AC 15	6 A	6 A	

Mechanical life
Electrical service life

2 million operating cycles
50.000 operating cycles
at 2 A 250 V DC L/R 20 ms

Permissible ambient temperature

Operation -40° C to +60° C
Storage -50° C to +80° C

Climate resistance
Damp heat constant
Damp heat cyclic
Degree of protection

DIN IEC 68 part 2-3
DIN IEC 68 part 2-30
IP 40 IEC 529 DIN 40050

Pos.				Weight gramm	Type	Price EURO
1	DC-contact normally closed (NC)			20	SO 1.10	
	Colour code grey or blue					
2	DC-contact normally open (NO)			20	SS 1.10	
	Colour code yellow or green					
3	Shock protection KEG 142 to DIN VDE 0106 Part 100				B	
4	Roller lever			10	R	
5	Toggle lever (switching in one direction only)			15	K	
6	Plug-in connection at side 4,8 x 0,8 mm (2 pieces)				F	
7	Contacts gold-coated approx. 0,2 µm				AU	
8	Contact without quenching magnets (for AC only) subtract price					
9	Contact without quenching magnets (for AC only) and without snap-action mechanism subtract price					

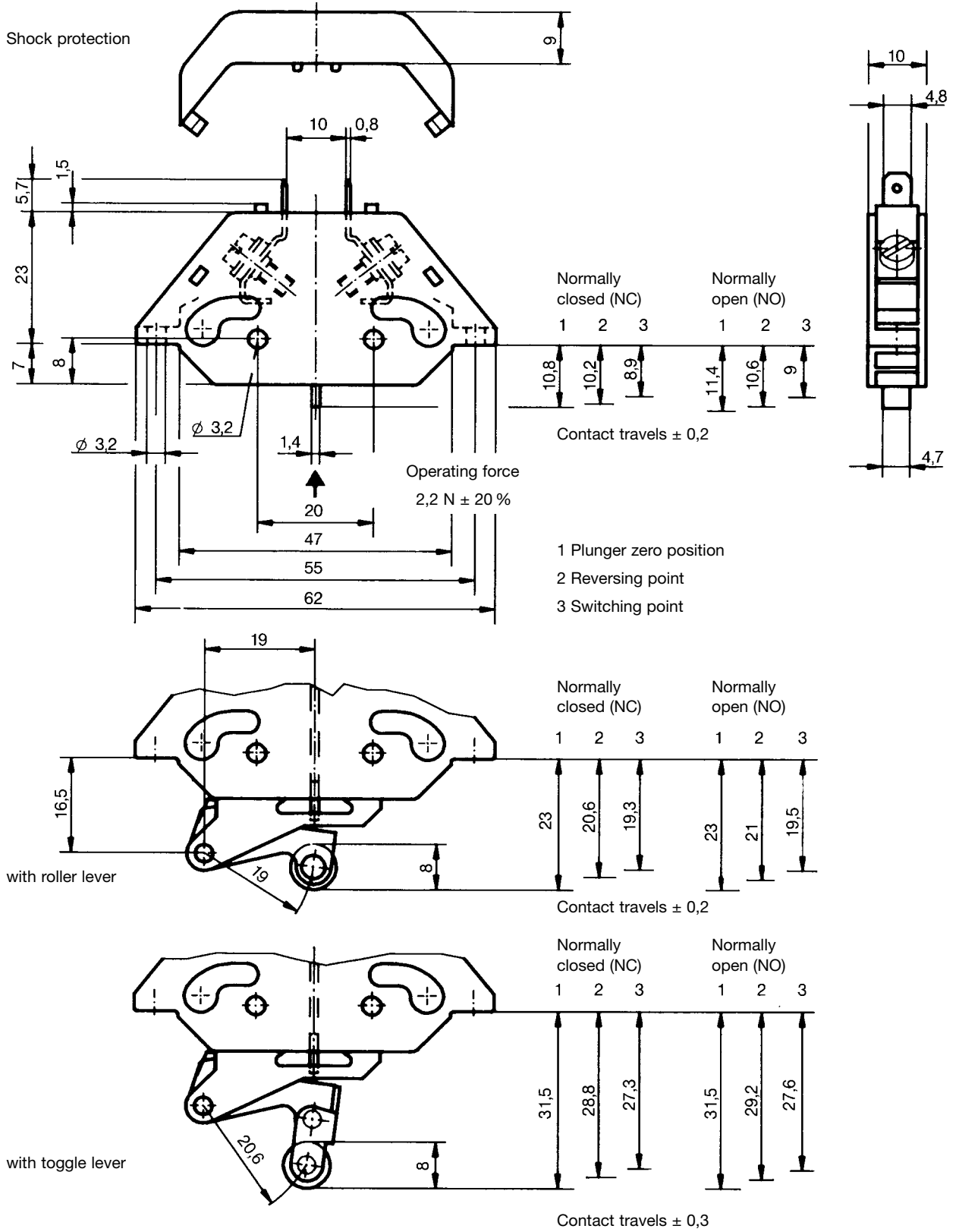

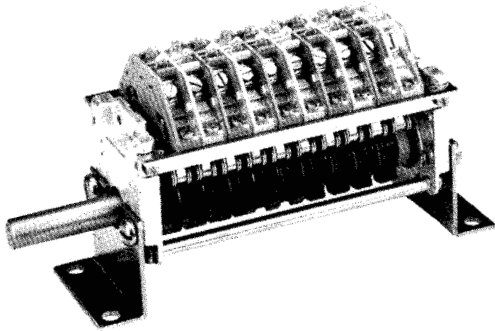

Type NU1-10-W...

The cam controller NU 1 is used as a signal and annunciation switch in HV systems. This rugged switching device to IEC 947-5-1 EN 60947 DIN VDE 0660-200 and VDE 0670/4 § 20 has cam disks made of insulation material that can be set at 10° intervals. **The switching rating of the contacts (NC with snap-action mechanism) is 6 A 250 V AC 15 or 2 A 250 V DC. Time constant L/R = 20 ms.** NO contacts can also be supplied. The DC contact blocks are designed to permit series assembly, which can then be operated simultaneously. This requires additional components for mounting the contacts.

Mechanical life	2 million operating cycles
Permissible ambient temperature	Operation -40° C to +60° C Storage -50° C to +80° C
Climate resistance	
Damp heat constant	DIN IEC 68 part 2-3
Damp heat cyclic	DIN IEC 68 part 2-30
Degree of protection (in housing)	IP 65 IEC 529 DIN 40050
Technical data look catalog 5/100	

Pos.				Weight gramm	Type	Price EURO
1	Signal-cam controller	No. of contacts	2	350	2	
2	with free shaftend 12 mm ø standard		4	460	4	
3	or 12 mm hexagonal		6	570	6	
4	Switching program		8	680	8	
5			10	790	10	
6			12	900	12	
7			14	1010	14	
8	or to your contact-arrangement		16	1120	16	
9	Switching program to your contact-arrangement		2			
10	Components for mounting series contacts on top		4	110	+4	
11	with DC-contacts		8	200	+8	
12			12	290	+12	
13			16	380	+16	
14						
15	Second free shaftend 12 mm ø standard or 12 mm hexagonal				F	
16	Spring return in 0-position			110	Z	
17	Switching sequence 4-0-4					
18	Mounting angles 2 pieces each signal-cam controller			80	W	
19	Link lever for shaft 12 mm ø standard or 12 mm hexagonal			70	GH	
21	Plastic-cover (Astralon)	up to max	4		A	
22	(Dust and shock protection)		8		A	
23			12		A	
24			16		A	
25	Shock protection KEG 142 for DC-contacts to DIN VDE 0106 Part 100					
30	Aluminium housing U 23 / 20 up to type 10			2500	U11	
31	Aluminium housing U 23 / 28 up to type 16			3000	U12	



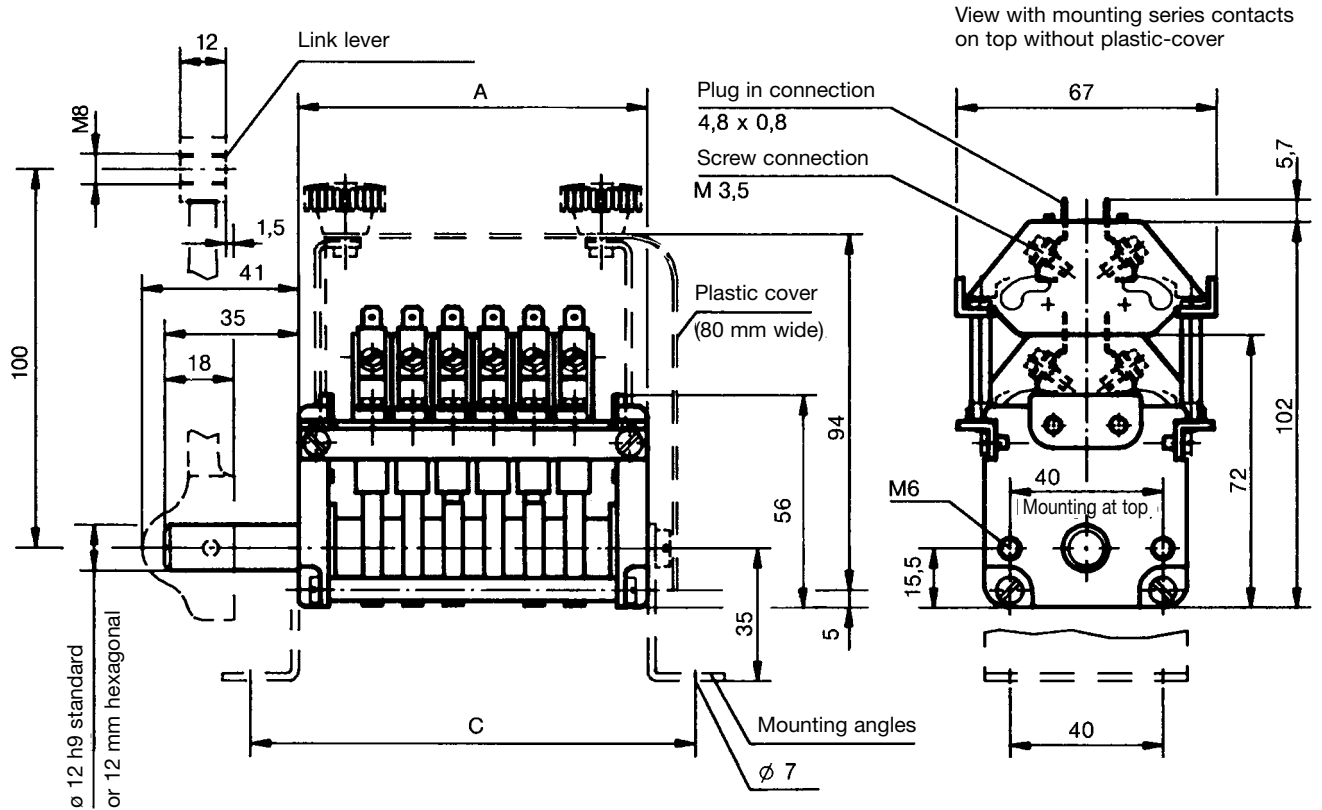

Type	No. of contact	Dimens. A	Dimens. C	Housing	Dimens. F	Dimens. G
2	2	49	74	U 23/20	180	202
4	4	70	95			
6	6	91	117			
8	8	113	138			
10	10	134	159			
12	12	155	180	U 23/28	260	280
14	14	176	201			
16	16	197	222			

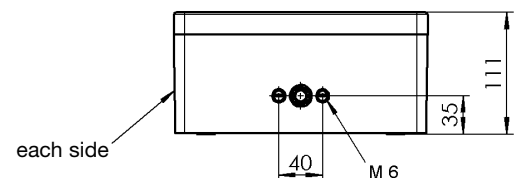
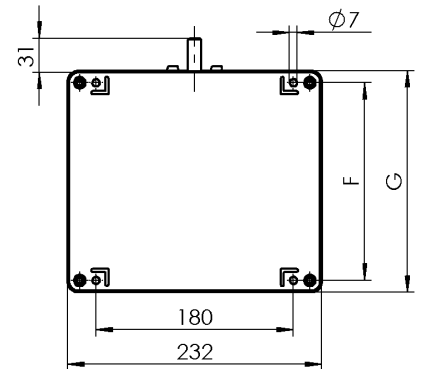

Example for type-sign
Signal-cam controller
No. of contacts
Link rod



Special please describe
Plastic-cover
Mounting angles

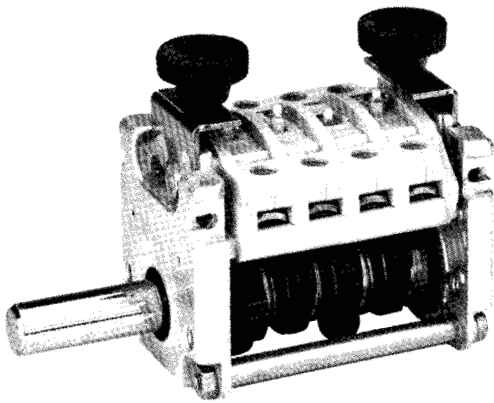

Type NU2-14-...

The cam controller NU 2 is used as a signal and announcement switch in HV systems. This rugged switching device to IEC 947-5-1 EN 60947 DIN VDE 0660-200 has cam disks made of insulation material that can be set at 10° intervals.

The switching rating of the contacts (positively opened) is 4 A 350 V AC 15 res. 1 A 24 V DC 13.

Mechanical life	6 million operating cycles
Permissible ambient temperature	Operation -40° C to +60° C Storage -50° C to +80° C
Climate resistance	
Damp heat constant	DIN IEC 68 part 2-3
Damp heat cyclic	DIN IEC 68 part 2-30
Degree of protection (in housing)	IP 65 IEC 529 DIN 40050
Technical data look catalog 5/100	

Pos.				Weight gramm	Type	Price EURO
1	Signal-cam controller	No. of contact	2	280	2	
2	with free shaftend 12 mm ø standard		4	380	4	
3	or 12 mm hexagonal		6	480	6	
4	Switching program		8	580	8	
5			10	680	10	
6			12	780	12	
7			14	880	14	
8	or to your contact-arrangement		16	980	16	
9	Switching program to your contact-arrangement		2			
10						
11	Second free shaftend 12 mm ø standard or 12 mm hexagonal				F	
12	Spring return in 0-position			110	Z	
13	Switching sequence 4-0-4					
14	Mounting angles 2 pieces each signal-cam controller			80	W	
15	Link lever for shaft 12 mm ø standard or 12 mm hexagonal			70	GH	
21	Plastic-cover (Astralon)	up to max.	4		A	
22	(Dust and shock protection)		8		A	
23			12		A	
24			16		A	
25						
30	Aluminium housing U 23 / 20 up to type 10			2500	U11	
31	Aluminium housing U 23 / 28 up to type 16			3000	U12	

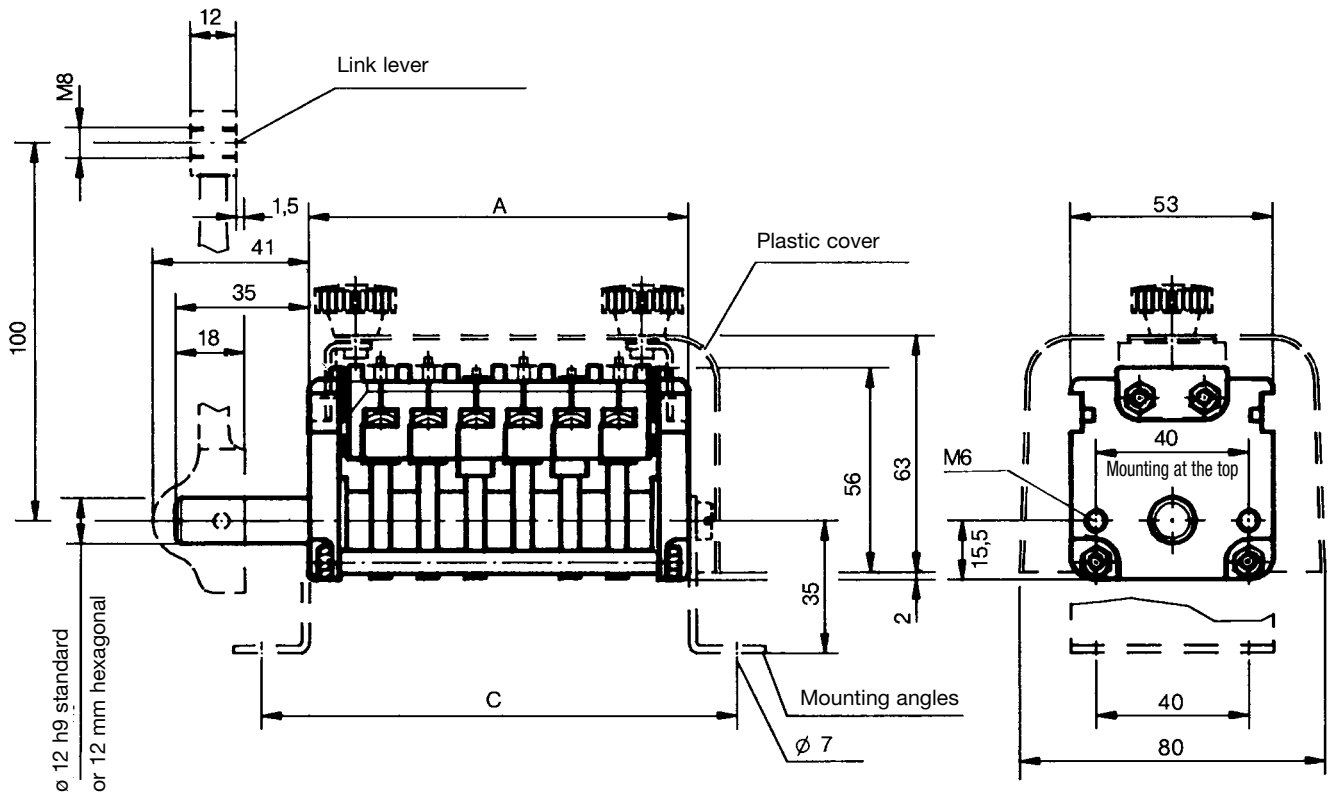

Type	No. of contact	Dimens. A	Dimens. C	Housing	Dimens. F	Dimens. G
2	2	50	75	U 23/20	180	202
4	4	75	100			
6	6	100	125			
8	8	125	150			
10	10	152	177			
12	12	177	202	U 23/28	260	280
14	14	202	227			
16	16	227	252			

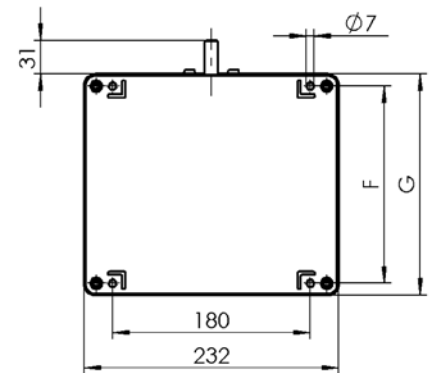

Aluminium housing protection IP 65

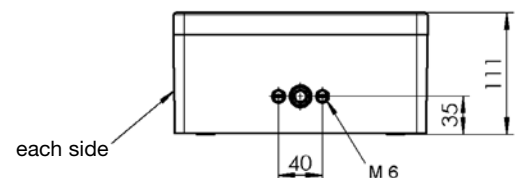

Example for type-sign
Signal-cam controller
No. of contacts
Spring return



Special please describe
Aluminium housing
Link rod

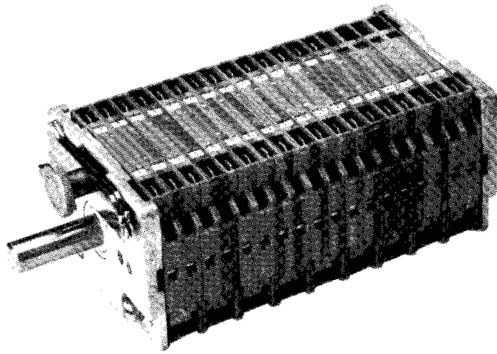

Type NU3-09-...

The cam controller NU 3 is used as a signal and announcement switch in HV systems. This rugged switching device to IEC 947-5-1 EN 60947 DIN VDE 0660-200 and VDE 0670/4 § 20 has cam disk that can be programmed.
The switching rating of the contacts (positively opened and positively closed) is 8 A 250 V AC 15 res. 2,5 A 250 V DC.
Time constant L/R = 20 ms.

Mechanical life	1 million operating cycles
Permissible ambient temperature	Operation -40° C to +60° C Storage -50° C to +80° C
Climate resistance	DIN IEC 68 part 2-3
Damp heat constant	DIN IEC 68 part 2-30
Damp heat cyclic	DIN IEC 68 part 2-30
Degree of protection (in housing)	IP 54 IEC 529 DIN 40050

Technical data look catalog 5/100

Pos.				Weight gramm	Type	Price EURO
1	Signal-cam controller	No. of contacts 2		450	01	
2	with free shaftend 12 mm ø standard	4		600	02	
3	or 12 mm hexagonal	6		750	03	
4	Contacts with connector lugs	8		900	04	
5	Switching program to your	10		1050	05	
6	contact-arrangement	12		1200	06	
7		14		1350	07	
8		16		1500	08	
9		18		1650	09	
10		20		1800	10	
11		22		1950	11	
12		24		2100	12	
13		26		2250	13	
14		28		2400	14	
15		30		2550	15	
16		32		2700	16	
20	Contacts with additional screw connection each	2				
21	Second free shaftend 12 mm ø standard or 12 mm hexagonal				F	
22	Spring return in 0-position			110	Z	
23	Switching sequence 4-0-4					
24	Mounting angles 2 pieces each signal-cam controller			80	W	
25	Link lever for shaft 12 mm ø standard or 12 mm hexagonal			70	GH	

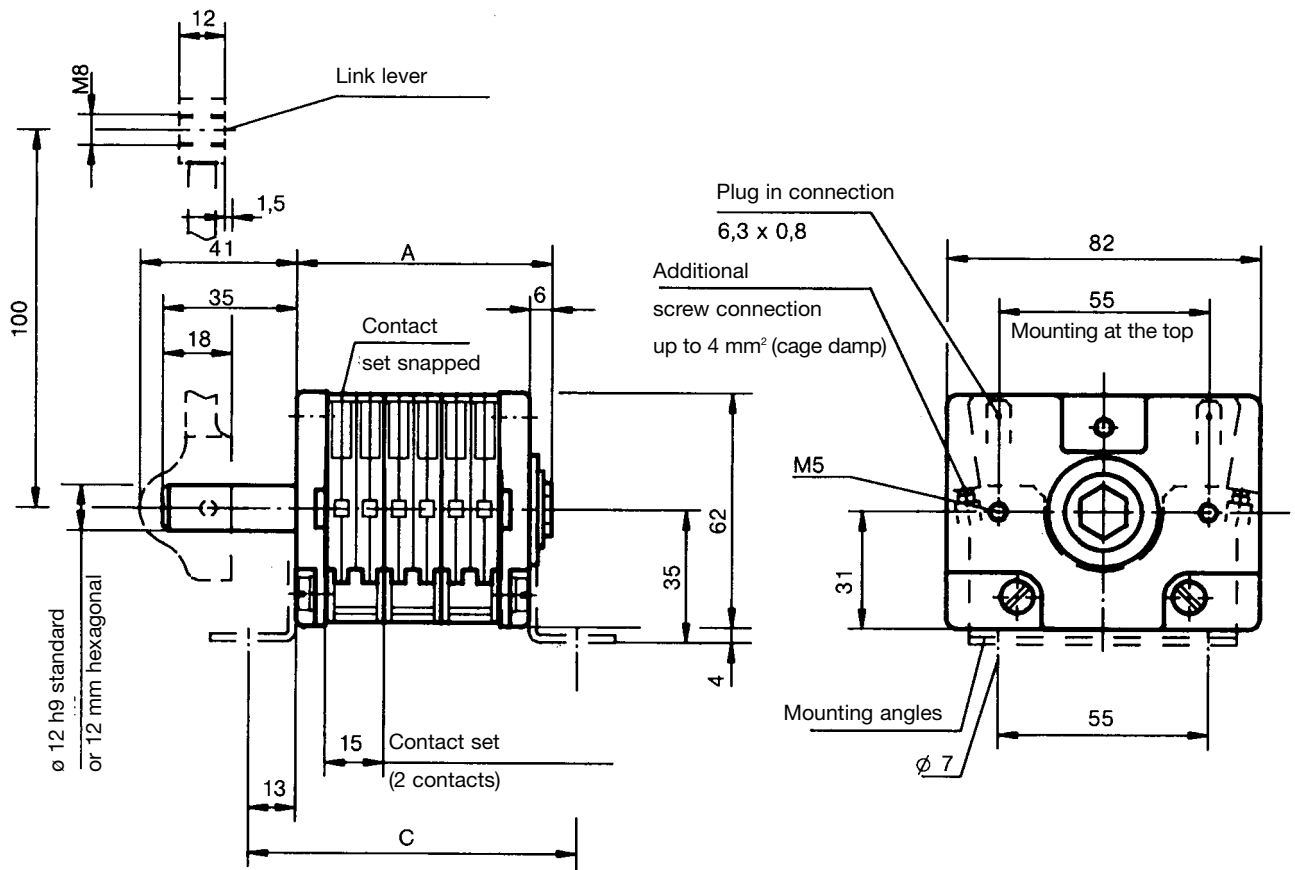

Type	No. of contacts	Dimension A	Dimension C
01	2	37	57
02	4	52	72
03	6	67	87
04	8	82	102
05	10	97	117
06	12	112	132
07	14	127	147
08	16	142	162
09	18	157	177
10	20	172	192
11	22	187	207
12	24	202	222
13	26	217	237
14	28	232	252
15	30	247	267
16	32	262	282

Example for type-sign
Signal-cam controller
No. of contacts
Second free shaftend

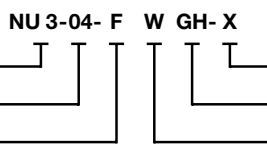

Special please describe
Link rod
Mounting angles

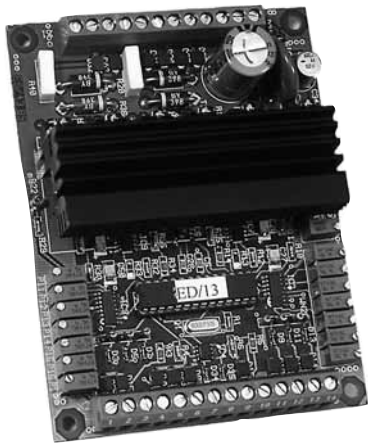

Type ES/43-10-...

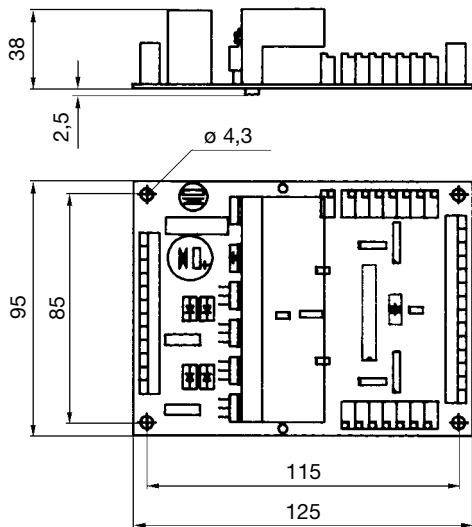

The electronic control unit ES / 43 serves for control of proportional valves without position control.

Features:

- Stabilized voltage
- Chopper output stage with adjustable frequency
- Ramp time setting ON / OFF delay
- Creep speed circuit adjustable
- Solenoid current setting separate for minimum current and maximum current
- Output current controlled independently of temperature and solenoid
- Power output short-circuit-proof with overload protection
- Voltage input protected against polarity reversal
- Mechanical selection of direction by means of contacts
- Actuation of 4 proportional valves solenoid connections drawing ES / 43-10
- Actuation of 2 proportional valves solenoid connections drawing ES / 43-11
- LED operating voltage and working display
- Microprocessor technology therefore especially adaptable

Characteristics:

- Supply voltage 10 ... 32 V DC
- Residual ripple 20%
- Control voltage range Ue 0 ... 5 V
- Control current Ie < 1 mA
- Dither frequency f 25 ... 250 Hz
- Proportional valve S 1-4
- Output I min. 0 ... 1 A
- Output I max. = I min ... 2 A at 12 Volt
- Output I max. = I min ... 1 A at 24 Volt
- Ramp time setting
- t on 0,2 ... 25 sec
- t off 0,2 ... 25 sec
- Creep speed variable reduction 25 ... 75%
- Operating temperature -20°C to +60°C
- Storage temperature -40°C to +80°C

Pos.				Weight gramm	Type	Price EURO
1	Electronic control unit for 4 proportional valves solenoid			250	ES/43-10	
2	Electronic control unit for 2 proportional valves solenoid			200	ES/43-11	
3						



ES / 43-10 4 Proportional valves-solenoid

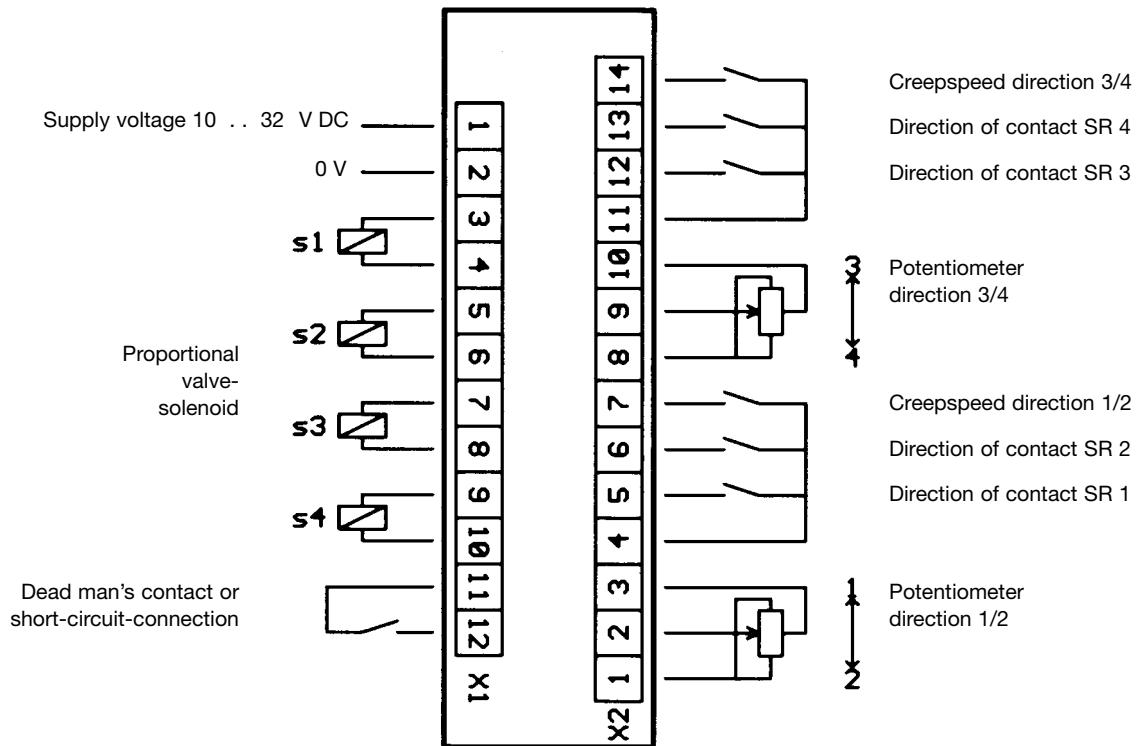

ES / 43-11 2 Proportional valves-solenoid

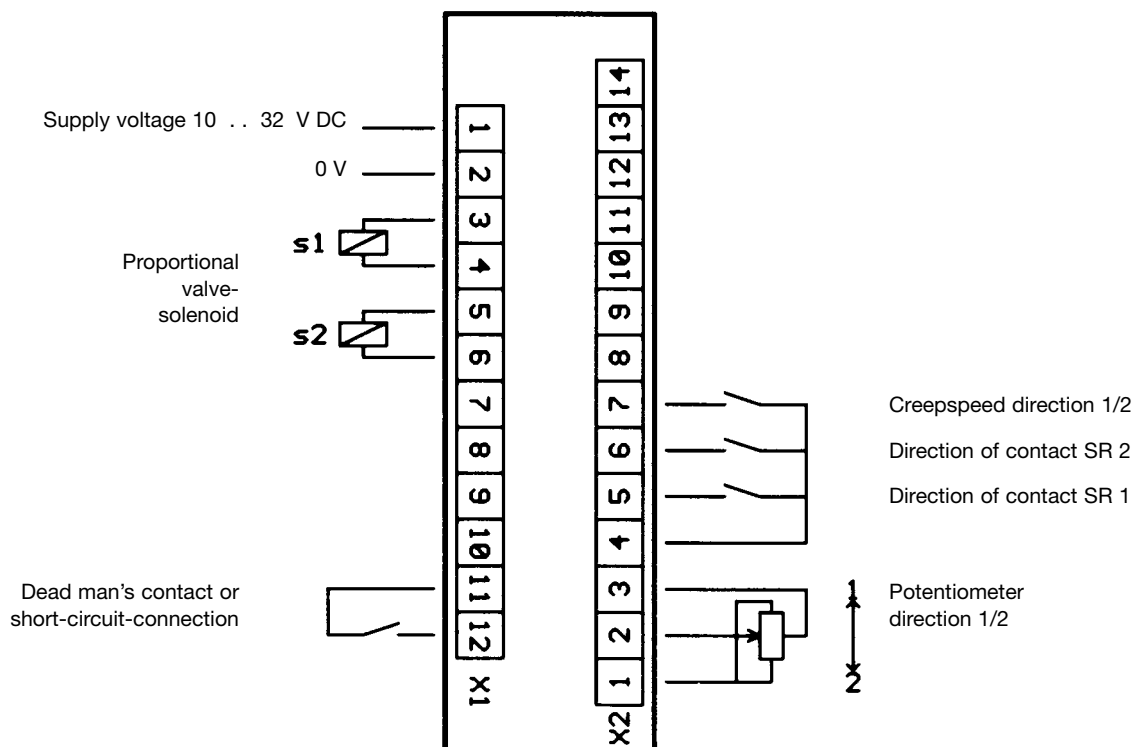



Pos.	for mounting on V 8 with potentiometer		Type	Weight gramm	Type	Price EURO
1	<p>Elektronik (Amplifier)</p> <p>Technical data:</p> <p>Power supply 8–32 V DC Current controlled PWM 0–1 A per axis can be a characteristic curve deposited</p> <p>Dither frequency 150 or 200 Hz adjustable</p> <p>Ramp time adjustable</p> <p>or</p> <p>Current input 4–20 mA Current output 2 A</p> <p>RS 232 interface with PC work parameter attitude and diagnosis</p> <p>Error journal for 41 errors with operating time active/inactively recognition</p> <p>Connector DT04-12P / DT06-12S</p>		ES/61	250	EV01	
90	<p>Humidity protection (circuit board moulded) for use with high condensation</p>					



ES/61-10

directions

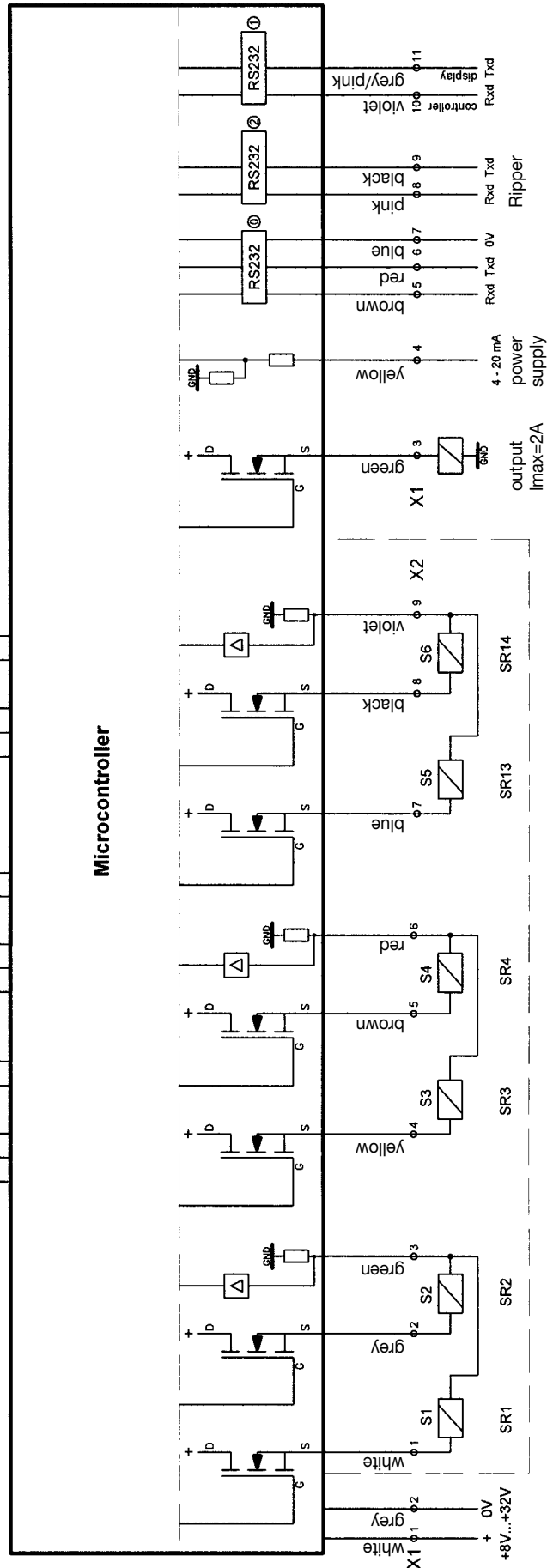
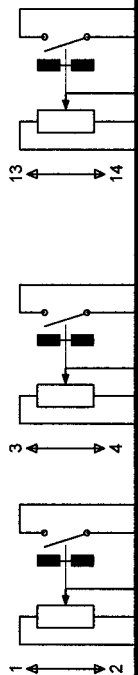
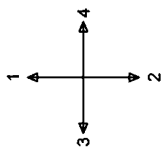

power supply: +8V ... +32V
 PWM-output: max 1A
 Frequency: 150/200 Hz ±10 Hz
 X1: 12 pol. „DEUTSCH“ Connector type: DT04-12P
 X2: 12 pol. „DEUTSCH“ Connector type: DT06-12S



Pos.	for mounting on: V 10, V 8, VV 8, D 8, P 10, P 11, P 12			Weight gramm	Type	Price EURO
10 11 12						
15 16 17						
30 31 32	Voltage output impressed 0-10 Volt electronic for 1 axis electronic for 2 axis Technical data: Power supply 18-30 V DC Output 0-10 Volt (+ 5 mA) Output characteristic linear	ANALOG	EP/84	150	EU01 EU02	
35 36 37	Voltage output impressed ± 10 Volt electronic for 1 axis electronic for 2 axis Technical data: Power supply 18-30 V DC Output ± 10 Volt (± 5 mA) Output characteristic linear	ANALOG	EP/84	150	EU03 EU04	
40 41 42	Output power impressed 0-20 mA electronic for 1 axis electronic for 2 axis Technical data: Power supply 18-30 V DC Output 0-20 mA Output characteristic linear	ANALOG	ER/16		EI01 EI02	
45 46 47	Output power impressed 4-20 mA electronic for 1 axis electronic for 2 axis Technical data: Power supply 18-30 V DC Output 4-20 mA Output characteristic linear	ANALOG	ER/16		EI03 EI04	
50 51 52	Output power impressed ± 20 mA electronic for 1 axis electronic for 2 axis Technical data: Power supply 18-30 V DC Output ± 20 mA Output characteristic linear	ANALOG	ER/44	150	EI05 EI06	
90	Humidity protection (circuit board moulded) for use with high condensation					



Pos.	for mounting on: V 85, WV 85, V 25			Weight gramm	Type	Price EURO
10 11 12	8bit Gray-code electronic for 1 axis electronic for 2 axis Technical data: Power supply 18-30 V DC Output PNP 24 V DC 10 mA) Output characteristic linear	DIGITAL	EP/340	150	ED11 ED12	
15 16 17	8bit Binär-code electronic for 1 axis electronic for 2 axis Technical data: Power supply 18-30 V DC Output PNP 24 V DC 10 mA) Output characteristic linear	DIGITAL	EP/340	150	ED13 ED14	
30 31 32	Voltage output impressed 0-10 Volt electronic for 1 axis electronic for 2 axis Technical data: Power supply 18-30 V DC Output 0-10 Volt (+ 5 mA) Output characteristic linear	ANALOG	EP/318	150	EU11 EU12	
35 36 37	Voltage output impressed ± 10 Volt electronic for 1 axis electronic for 2 axis Technical data: Power supply 18-30 V DC Output ± 10 Volt (± 5 mA) Output characteristic linear	ANALOG	EP/318	150	EU13 EU14	
40 41 42						
45 46 47	Output power impressed 4-20 mA electronic for 1 axis electronic for 2 axis Technical data: Power supply 18-30 V DC Output 4-20 mA Output characteristic linear	ANALOG		150	E113 E114	
50 51 52						
90	Humidity protection (circuit board moulded) for use with high condensation					



Pos.	for mounting on: V 10, V 8, VV 8, D 8, P 10, P 11, P 12			Weight gramm	Type	Price EURO
1	<p>Electronic Profi-Bus DP</p> <p>Technical data: Power supply 18-30 V DC distinctively poled</p> <p>Profi-Bus Baud rate max. 12 MBit/s</p> <p>Address outside adjustable 0...99 by rotary switch (default 99)</p> <p>potentiometer output value 0 / 128 / 255 or 255 / 0 / 255</p> <p>Input 3 analog ports for 3 potentiometers (3-axis)</p> <p>6 digital ports for 3 x 2 direction-contacts</p> <p>8 digital ports for 8 switches</p> <p>Connection D-SUB 9 socket (female insert)</p> <p>3 B-line</p> <p>4 RTS</p> <p>5 GND</p> <p>6 +5 V</p> <p>8 A-line</p> <p>Connector 2-pole</p> <p>1 24 V</p> <p>2 0 V</p> <p>Communication Profi-Bus DP (DIN 192 45 section 3)</p> <p>Ident-No. 068 BH</p>		EB/85		EPB01	
90	Humidity protection (circuit board moulded) for use with high condensation					



Pos.	for mounting on: V 85, WV 85, V 25			Weight gramm	Type	Price EURO
1	<p>Electronic Profi-Bus DP</p> <p>Technical data: Power supply 18-30 V DC distinctively poled</p> <p>Profi-Bus Baud rate max. 12 MBit/s</p> <p>Address outside adjustable 0...99 by rotary switch (default 99)</p> <p>Hallsensors output value 0 / 128 / 255 or 255 / 0 / 255</p> <p>Input 3 analog ports for 3 potentiometers (3-axis)</p> <p>6 digital ports for 3 x 2 direction-contacts</p> <p>8 digital ports for 8 switches</p> <p>Connection D-SUB 9 socket (female insert)</p> <p>3 B-line</p> <p>4 RTS</p> <p>5 GND</p> <p>6 +5 V</p> <p>8 A-line</p> <p>Connector 2-pole</p> <p>1 24 V</p> <p>2 0 V</p> <p>Communication Profi-Bus DP (DIN 192 45 section 3)</p> <p>Ident-No. 068 BH</p>		EB/85	150	EPB11	
90	Humidity protection (circuit board moulded) for use with high condensation					



Pos.	for mounting on: V 10, V 8, VV 8, D 8, P 10, P 11, P 12			Weight gramm	Type	Price EURO
1	<p>Electronic CAN-Bus</p> <p>Technical data: Power supply 9-36 V DC distinctively poled</p> <p>CAN-Bus level: physical layer acc. ISO 11898</p> <p>Baud rate 125 kBit/s...1Mbit/s</p> <p>Bus-exclusion DIP switch hook up</p> <p>Identifier / CAN-open-ID adjustable by DIP switch</p> <p>Input 4 analog ports for 4 potentiometer (4-axis)</p> <p>8 digital ports for 4 x 2 direction-contacts</p> <p>8 digital ports for 8 switches</p> <p>Connection D-SUB 9 socket protection IP 65 (male)</p> <p>2 CAN-L in</p> <p>3 GND</p> <p>7 CAN-H in</p> <p>9 Supply voltage</p> <p>Connection D-SUB 9 socket protection IP 65 (female)</p> <p>2 CAN-L out</p> <p>3 GND</p> <p>7 CAN-H out</p> <p>9 Supply voltage</p> <p>Protocol CAN-Open according to C/ADS 301 or customer preference</p> <p>Parameters or configurations will be stored in existing EEPROM</p>		T 646 EB/40	150	ECB01	
90	Humidity protection (circuit board moulded) for use with high condensation					



Pos.		Type	Weight gramm	Type	Price EURO
1	Elektronic CAN-Bus I/O card Technical data: Power supply 9–36 V distinctively poled Baudrate 125 KBit/s Bus-Exclusion DIP switch hook up Identifier / CAN-open-ID adjustable by DIP switch Input: Output: Connection; Connector pin and socket	EB/49	100	ECB02	

Electrical diagram

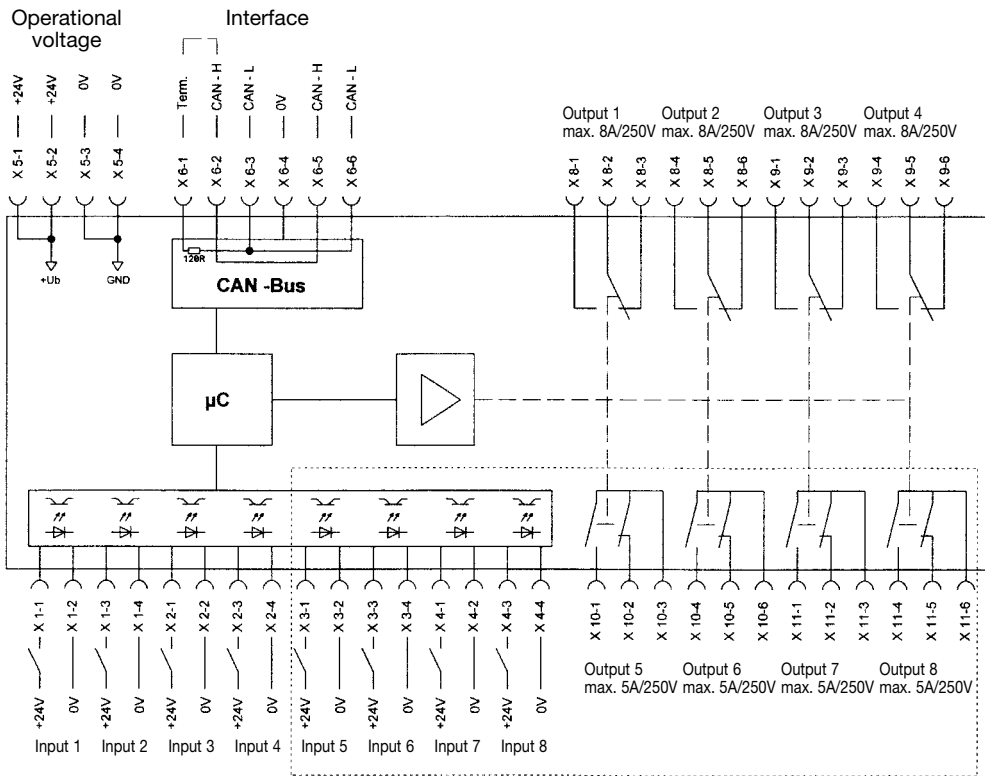

Scale drawing

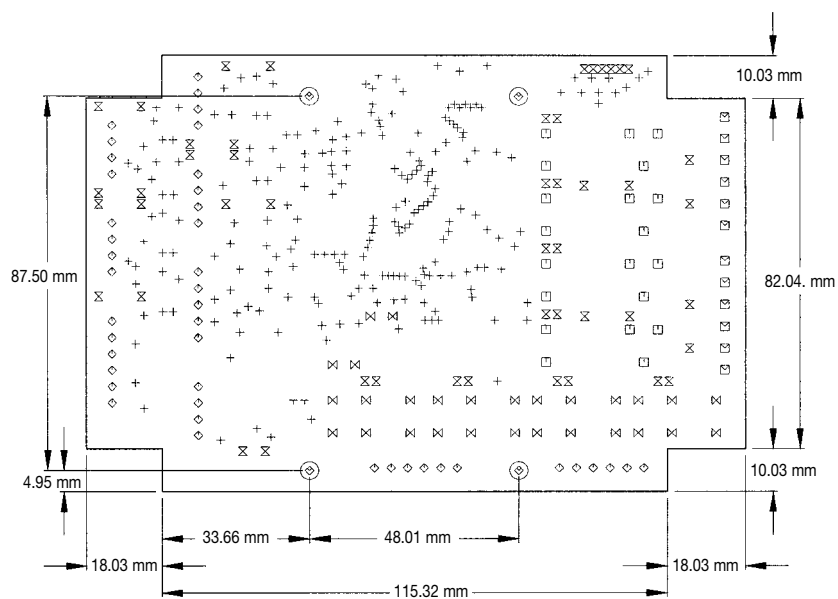

50	Plastic housing (EMV) 120x170x66 with 3 holes for cable entry M20		350	I	
90	Humidity protection (circuit board moulded) for use with high condensation				



Pos.	for mounting on: V 85, VV 85, V 25			Weight gramm	Type	Price EURO
1	<p>Electronic CAN-Bus</p> <p>Technical data: Power supply 9-36 V DC distinctively poled</p> <p>CAN-Bus level: physical layer acc. ISO 11898</p> <p>Baud rate 125 kBit/s...1Mbit/s</p> <p>Bus-exclusion DIP switch hook up</p> <p>Identifier / CAN-open-ID adjustable by DIP switch</p> <p>Input 4 analog ports for 4 potentiometer (4-axis)</p> <p>8 digital ports for 4 x 2 direction-contacts</p> <p>8 digital ports for 8 switches</p> <p>Connection D-SUB 9 socket protection IP 65 (male)</p> <p>2 CAN-L in</p> <p>3 GND</p> <p>7 CAN-H in</p> <p>9 Supply voltage</p> <p>Connection D-SUB 9 socket protection IP 65 (female)</p> <p>2 CAN-L out</p> <p>3 GND</p> <p>7 CAN-H out</p> <p>9 Supply voltage</p> <p>Protocol CAN-Open according to C/ADS 301 or customer preference</p> <p>Parameters or configurations will be stored in existing EEPROM</p>			150	ECB11	
90	Humidity protection (circuit board moulded) for use with high condensation					



GESSMANN
Industrial controllers

Notice

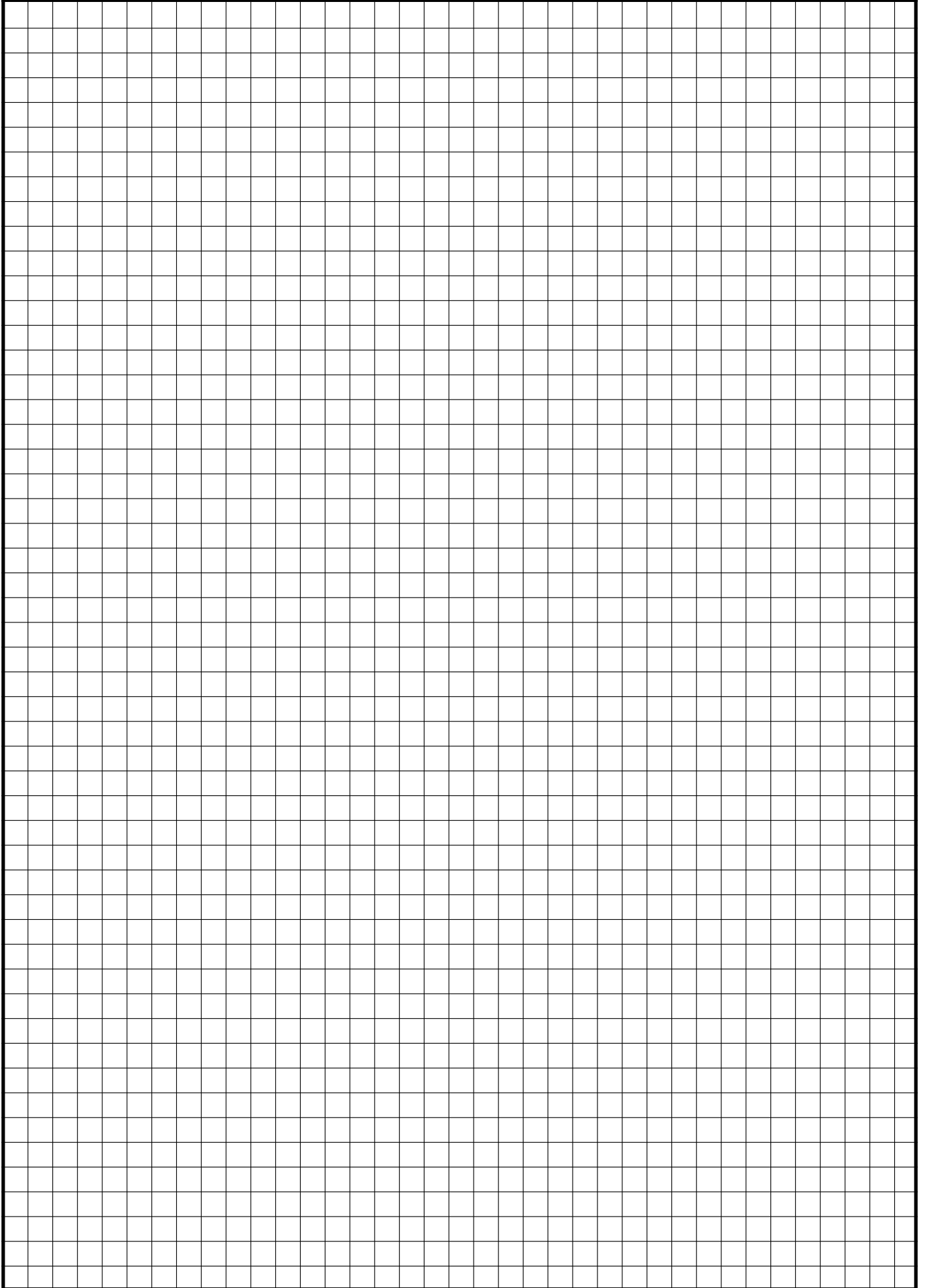



Pos.	Type	Type	Pos.	Type	Type
01	MS 11	A01	12	MS 214	A12
02	MS 12	A02			
03	MS 13	A03			
04	MS 14	A04			
05	MS 21	A05			
06	MS 22	A06			
07	MS 212	A07			
08	MS 222	A08			
09	MS 23	A09			
10	MS 213	A10			
11	MS 24	A11	13	MS 224	A13
			14	MS 25	A14
			15	MS 26	A15
			16	MS 0	A98
			17	Contact-arrangement special	A99
			18	Contact in 0-position normally closed (NC)	A...0
			19	Contact in 0-position normally open (NO)	A...1
			20	Potentiometer MSP	
			11	MS 24	A11

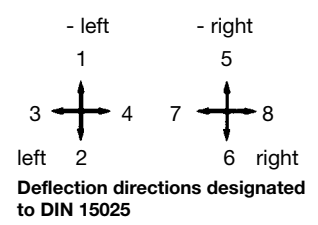



Customer _____ Order No. _____

Multi-axis controller
Left / right
Indicating label
Black
Engraved white
Lettering height
3,5 mm

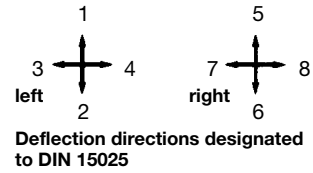
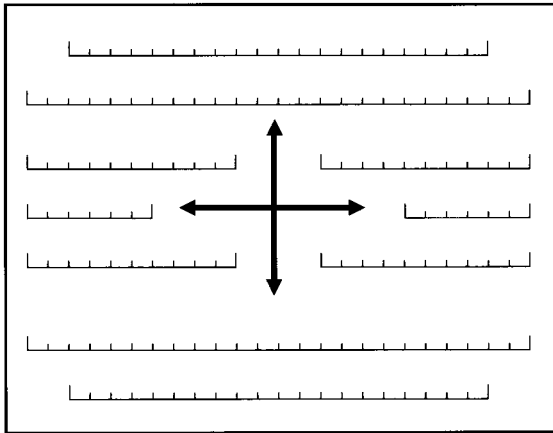

Direction 1-2 / 5-6 _____ Direction 3-4 / 7-8 _____

Switching program _____ Switching program _____

Drive _____ Plant ref. _____ Drive _____ Plant ref. _____

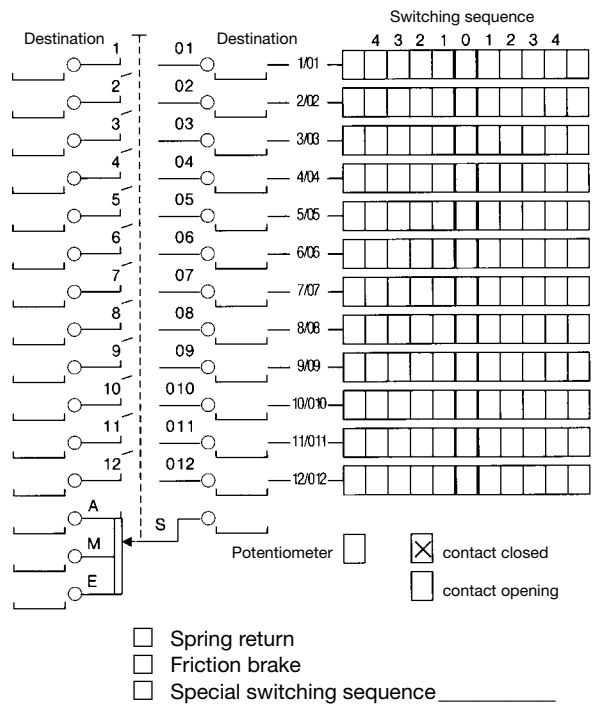
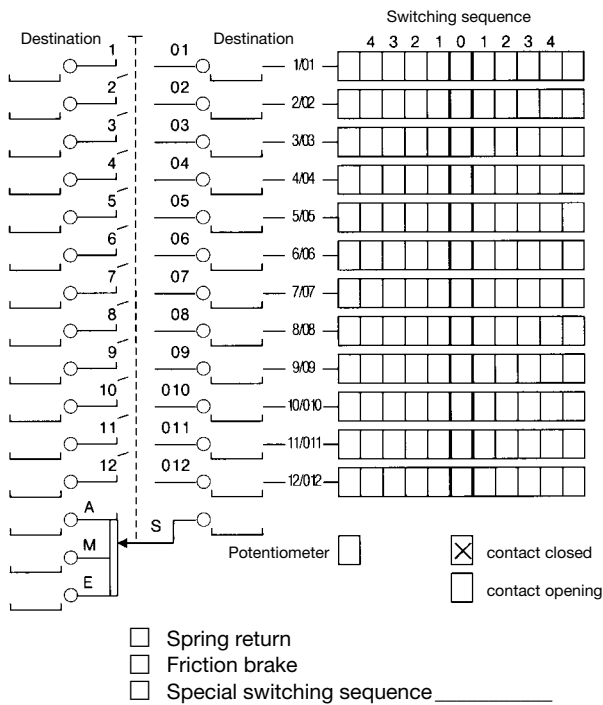

Additional functions in the control-handle _____

Dead man's button T Signal button H Push button D
 Destination _____ Destination _____ Function _____ Destination _____

Control-handle long or short _____ mm _____

Gate cross-shaped Gate special-shaped (enclose drawing)

Type key: Type _____

X = _____



Customer _____ Order No. _____

Equipment box left

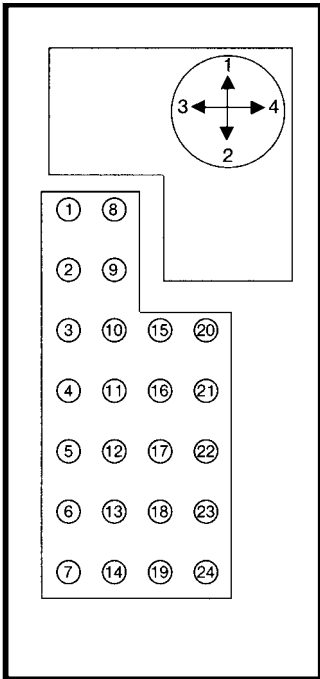

Position No.	Type	Colour	Label text (max. 2 x 12 characters)	Plant ref.	Destination	Notes
1	_____	_____	_____	_____	_____	_____
2	_____	_____	_____	_____	_____	_____
3	_____	_____	_____	_____	_____	_____
4	_____	_____	_____	_____	_____	_____
5	_____	_____	_____	_____	_____	_____
6	_____	_____	_____	_____	_____	_____
7	_____	_____	_____	_____	_____	_____
8	_____	_____	_____	_____	_____	_____
9	_____	_____	_____	_____	_____	_____
10	_____	_____	_____	_____	_____	_____
11	_____	_____	_____	_____	_____	_____
12	_____	_____	_____	_____	_____	_____
13	_____	_____	_____	_____	_____	_____
14	_____	_____	_____	_____	_____	_____
15	_____	_____	_____	_____	_____	_____
16	_____	_____	_____	_____	_____	_____
17	_____	_____	_____	_____	_____	_____
18	_____	_____	_____	_____	_____	_____
19	_____	_____	_____	_____	_____	_____
20	_____	_____	_____	_____	_____	_____
21	_____	_____	_____	_____	_____	_____
22	_____	_____	_____	_____	_____	_____
23	_____	_____	_____	_____	_____	_____
24	_____	_____	_____	_____	_____	_____

Maximum installation of command and indicating devices 22 (look 1/360) in our control units and housings if our multi-axis controllers V 62 (look 1/100) are used. Additional command and indicating devices can be installed if multi-axis controllers V 64 or V 11 (look 1/110) are used. (please enquire)

Control unit (look 2/020 ...)

Type		No. of pieces max.
KST 2/3	1 - 6, 8 - 13, 15 - 18	16
KST 41/181	1 - 5, 10 - 12	8
KST 42/182	1 - 5, 8 - 12, 15 - 17	13
KST 51/151	3 - 7, 10 - 14, 15 - 19, 20 - 24	20
KST 52/54/152/154	1 - 24	24
KST 6	3 - 4, 10 - 11, 15 - 16	6
KST 7	1 - 24	24
KST 75	1 - 19	19



Customer _____ Order No. _____

Position No.	Type	Colour	Label text (max. 2 x 12 characters)	Plant ref.	Destination	Notes
25	_____	_____	_____	_____	_____	_____
26	_____	_____	_____	_____	_____	_____
27	_____	_____	_____	_____	_____	_____
28	_____	_____	_____	_____	_____	_____
29	_____	_____	_____	_____	_____	_____
30	_____	_____	_____	_____	_____	_____
31	_____	_____	_____	_____	_____	_____
32	_____	_____	_____	_____	_____	_____
33	_____	_____	_____	_____	_____	_____
34	_____	_____	_____	_____	_____	_____
35	_____	_____	_____	_____	_____	_____
36	_____	_____	_____	_____	_____	_____
37	_____	_____	_____	_____	_____	_____
38	_____	_____	_____	_____	_____	_____
39	_____	_____	_____	_____	_____	_____
40	_____	_____	_____	_____	_____	_____
41	_____	_____	_____	_____	_____	_____
42	_____	_____	_____	_____	_____	_____
43	_____	_____	_____	_____	_____	_____
44	_____	_____	_____	_____	_____	_____
45	_____	_____	_____	_____	_____	_____
46	_____	_____	_____	_____	_____	_____
47	_____	_____	_____	_____	_____	_____
48	_____	_____	_____	_____	_____	_____

Equipment box right

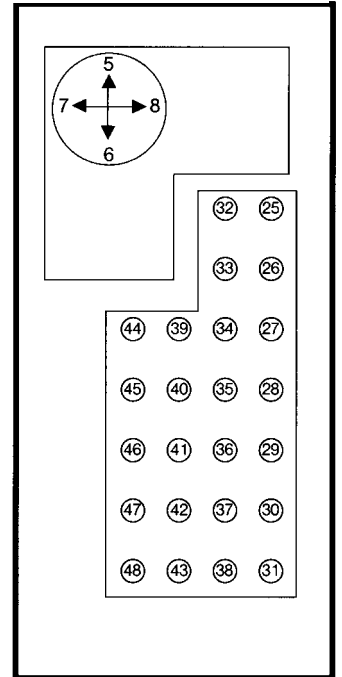

Maximum installation of command and indicating devices 22 (look 1/360) in our control units and housings if our multi-axis controllers V 62 (look 1/100) are used. Additional command and indicating devices can be installed if multi-axis controllers V 64 or V 11 (look 1/110) are used. (please enquire)

	No. of pieces max.	Control unit (look 2/020 ...) Type
25 - 30, 32 - 37, 39 - 42	16	KST 2/3
25 - 29, 34 - 36	8	KST 41/181
25 - 29, 32 - 36, 39 - 41	13	KST 42/182
27 - 31, 34 - 38, 39 - 43, 44 - 48	20	KST 51/151
25 - 48	24	KST 52/54/152/154
27 - 28, 34 - 35, 39 - 40	6	KST 6
25 - 48	24	KST 7
25 - 43	19	KST 75



Customer _____ Order No. _____

Equipment box left	Position No.	Type	Colour	Label text (max. 2 x 12 characters)	Plant ref.	Destination	Notes
<p>Max. 6 pcs. installation of command and indicating devices 22 (look 1/360) or 1 pcs. monitoring device 72 x 72 mm</p> <p>Multi-axis controller V 64 (look 1/100) or V 11 (look 1/110)</p> <p>Max. 3 pcs. installation of command and indicating devices 22 (look 1/360)</p> <p>Place to put on devices</p>	1	_____	_____	_____	_____	_____	_____
	2	_____	_____	_____	_____	_____	_____
	3	_____	_____	_____	_____	_____	_____
	4	_____	_____	_____	_____	_____	_____
	5	_____	_____	_____	_____	_____	_____
	6	_____	_____	_____	_____	_____	_____
	7	_____	_____	_____	_____	_____	_____
	8	_____	_____	_____	_____	_____	_____
	9	_____	_____	_____	_____	_____	_____
	10	_____	_____	_____	_____	_____	_____
	11	_____	_____	_____	_____	_____	_____
	12	_____	_____	_____	_____	_____	_____

Equipment box right	Position No.	Type	Colour	Label text (max. 2 x 12 characters)	Plant ref.	Destination	Notes
<p>Max. 6 pcs. installation of command and indicating devices 22 (look 1/360) or 1 pcs. monitoring device 72 x 72 mm</p> <p>Multi-axis controller V 64 (look 1/100) or V 11 (look 1/110)</p> <p>Max. 3 pcs. installation of command and indicating devices 22 (look 1/360)</p> <p>Place to put on devices</p>	13	_____	_____	_____	_____	_____	_____
	14	_____	_____	_____	_____	_____	_____
	15	_____	_____	_____	_____	_____	_____
	16	_____	_____	_____	_____	_____	_____
	17	_____	_____	_____	_____	_____	_____
	18	_____	_____	_____	_____	_____	_____
	19	_____	_____	_____	_____	_____	_____
	20	_____	_____	_____	_____	_____	_____
	21	_____	_____	_____	_____	_____	_____
	22	_____	_____	_____	_____	_____	_____
	23	_____	_____	_____	_____	_____	_____
	24	_____	_____	_____	_____	_____	_____



Customer _____ Order No. _____

Equipment box left

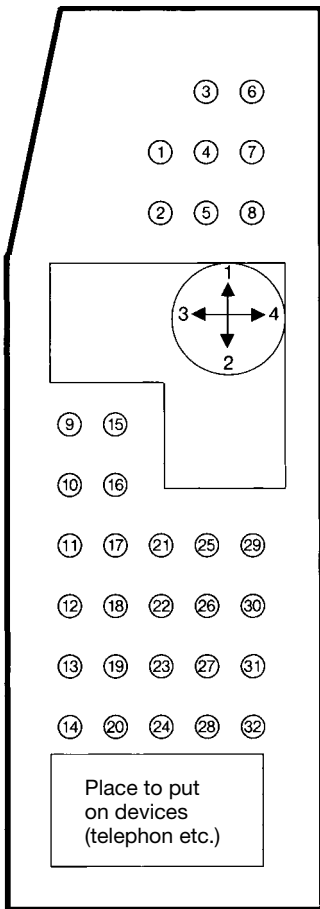

Position Nr.	Type	Colour	Label text (max. 2 x 12 characters)	Plant ref.	Destination	Notes
1	_____	_____	_____	_____	_____	_____
2	_____	_____	_____	_____	_____	_____
3	_____	_____	_____	_____	_____	_____
4	_____	_____	_____	_____	_____	_____
5	_____	_____	_____	_____	_____	_____
6	_____	_____	_____	_____	_____	_____
7	_____	_____	_____	_____	_____	_____
8	_____	_____	_____	_____	_____	_____
9	_____	_____	_____	_____	_____	_____
10	_____	_____	_____	_____	_____	_____
11	_____	_____	_____	_____	_____	_____
12	_____	_____	_____	_____	_____	_____
13	_____	_____	_____	_____	_____	_____
14	_____	_____	_____	_____	_____	_____
15	_____	_____	_____	_____	_____	_____
16	_____	_____	_____	_____	_____	_____
17	_____	_____	_____	_____	_____	_____
18	_____	_____	_____	_____	_____	_____
19	_____	_____	_____	_____	_____	_____
20	_____	_____	_____	_____	_____	_____
21	_____	_____	_____	_____	_____	_____
22	_____	_____	_____	_____	_____	_____
23	_____	_____	_____	_____	_____	_____
24	_____	_____	_____	_____	_____	_____
25	_____	_____	_____	_____	_____	_____
26	_____	_____	_____	_____	_____	_____
27	_____	_____	_____	_____	_____	_____
28	_____	_____	_____	_____	_____	_____
29	_____	_____	_____	_____	_____	_____
30	_____	_____	_____	_____	_____	_____
31	_____	_____	_____	_____	_____	_____
32	_____	_____	_____	_____	_____	_____

Maximum installation of command and indicating devices 22 (look 1/360) if our multiaxis controllers V 62 (look 1/100) are used.
Additional command and indicating devices can be installed if multi-axis controller V 64 or V 11 (look 1/110) are used.
(please enquire)

Pos. 1-8 alternative
max. 2 pcs. monitoring
devices 72 x 72 mm



Customer _____ Order No. _____

Position Nr.	Type	Colour	Label text (max. 2 x 12 characters)	Plant ref.	Desti-nation	Notes
35	_____	_____	_____	_____	_____	_____
36	_____	_____	_____	_____	_____	_____
37	_____	_____	_____	_____	_____	_____
38	_____	_____	_____	_____	_____	_____
39	_____	_____	_____	_____	_____	_____
40	_____	_____	_____	_____	_____	_____
41	_____	_____	_____	_____	_____	_____
42	_____	_____	_____	_____	_____	_____
43	_____	_____	_____	_____	_____	_____
44	_____	_____	_____	_____	_____	_____
45	_____	_____	_____	_____	_____	_____
46	_____	_____	_____	_____	_____	_____
47	_____	_____	_____	_____	_____	_____
48	_____	_____	_____	_____	_____	_____
49	_____	_____	_____	_____	_____	_____
50	_____	_____	_____	_____	_____	_____
51	_____	_____	_____	_____	_____	_____
52	_____	_____	_____	_____	_____	_____
53	_____	_____	_____	_____	_____	_____
54	_____	_____	_____	_____	_____	_____
55	_____	_____	_____	_____	_____	_____
56	_____	_____	_____	_____	_____	_____
57	_____	_____	_____	_____	_____	_____
58	_____	_____	_____	_____	_____	_____
59	_____	_____	_____	_____	_____	_____
60	_____	_____	_____	_____	_____	_____
61	_____	_____	_____	_____	_____	_____
62	_____	_____	_____	_____	_____	_____
63	_____	_____	_____	_____	_____	_____
64	_____	_____	_____	_____	_____	_____
65	_____	_____	_____	_____	_____	_____
66	_____	_____	_____	_____	_____	_____

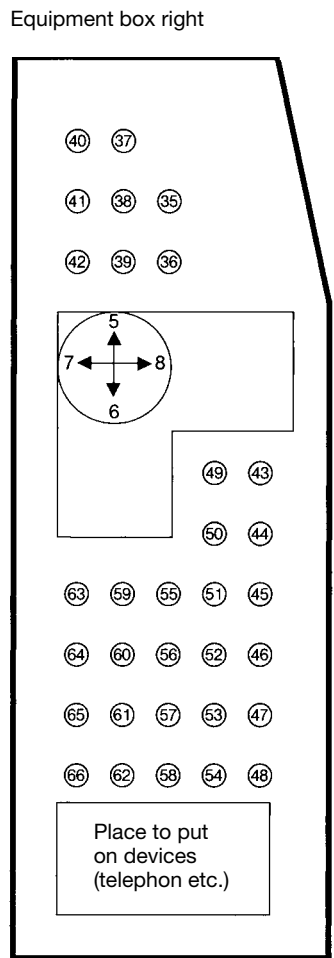

Maximum installation of command and indicating devices 22 (look 1/360) if our multiaxis controllers V 62 (look 1/100) are used. Additional command and indicating devices can be installed if multi-axis controller V 64 or V 11 (look 1/110) are used. (please enquire)

Pos. 35-42 alternative max. 2 pcs. monitoring devices 72 x 72 mm

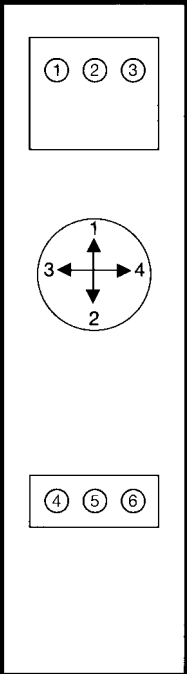

Customer _____ Order No. _____

Equipment box left	Position No.	Type	Colour	Label text (max. 2 x 12 characters)	Plant ref.	Destination	Notes
 <p>Max. 3 pcs. installation of command and indicating devices 22 (look 1/360)</p> <p>Multi-axis controller V 11 (look 1/110) or V 8 (look 1/130)</p> <p>Max. 3 pcs. installation of command and indicating devices 22 (look 1/360)</p>	1	_____	_____	_____	_____	_____	_____
	2	_____	_____	_____	_____	_____	_____
	3	_____	_____	_____	_____	_____	_____
	4	_____	_____	_____	_____	_____	_____
	5	_____	_____	_____	_____	_____	_____
	6	_____	_____	_____	_____	_____	_____
	7	_____	_____	_____	_____	_____	_____
	8	_____	_____	_____	_____	_____	_____
	9	_____	_____	_____	_____	_____	_____

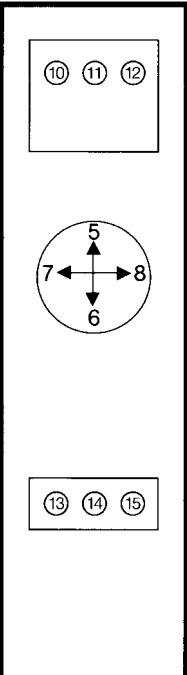
Equipment box right	Position No.	Type	Colour	Label text (max. 2 x 12 characters)	Plant ref.	Destination	Notes
 <p>Max. 3 pcs. installation of command and indicating devices 22 (look 1/360)</p> <p>Multi-axis controller V 11 (look 1/110) or V 8 (look 1/130)</p> <p>Max. 3 pcs. installation of command and indicating devices 22 (look 1/360)</p>	10	_____	_____	_____	_____	_____	_____
	11	_____	_____	_____	_____	_____	_____
	12	_____	_____	_____	_____	_____	_____
	13	_____	_____	_____	_____	_____	_____
	14	_____	_____	_____	_____	_____	_____
	15	_____	_____	_____	_____	_____	_____
	16	_____	_____	_____	_____	_____	_____
	17	_____	_____	_____	_____	_____	_____
	18	_____	_____	_____	_____	_____	_____



Utilization categories for control switches to IEC 947-5-1 EN 60947 DIN VDE 0660-200.

Type of current	Utilization category	Typical examples of application	Normal conditions of use					
			Make			Break		
		I = current made, I _c = current broken I _e = rated operational current, U = voltage before make U _e = rated operational voltage U _r = recovery voltage t _{0,95} = time in ms, to reach 95% of the steady-state current. P = U _e · I _e = steady-state power consumption in watts	$\frac{I}{I_e}$	$\frac{U}{U_e}$	cos φ	$\frac{I_c}{I_e}$	$\frac{U_r}{U_e}$	cos φ
AC	AC 12	Control of resistive loads and solid state loads with isolation by opto couplers	1	1	0,9	1	1	0,9
	AC 15	Control of a.c. electromagnetic loads (> 72 VA)	10	1	0,3	1	1	0,3
			$\frac{I}{I_e}$	$\frac{U}{U_e}$	t 0,95	$\frac{I_c}{I_e}$	$\frac{U_r}{U_e}$	t 0,95
DC	DC 12	Control of resistive loads and solid state loads with isolation by opto couplers	1	1	1 ms	1	1	1 ms
	DC 13	Control of d.c. electromagnets	1	1	6 · P	1	1	6 · P

The value 6 · P results from an empirical relationship with is found to represent most d.c. magnetic loads to an upper limit of P = 50 W viz 6 · P = 300 ms. Loads having power consumption greater than 50 W are assumed to consist of smaller loads in parallel. Therefore 300 ms is to be an upper limit, irrespective of the power consumption value.

Attach our switching device	V 6 S 6 N 61	N 6 N 62	VV 6 DD 64	V 11	V 5 S 2-S 23	VV 5 SS2-SS21	V 8 V 85 D 8	VV 8 VV 85 D 3 S 3	V 10 V 25 S 1	V 14 S 14	V 3	dead man's button signal button push button
Rated isolation voltage in Volt U _i	250		250	250	250	250	110	110	110	250	500	250
Rated operational voltage in Volt U _e	250		250	250	250	250	110	110	110	250	350	250
Rated operational current in Ampere I _e AC 12	6 or 16		6 or 16	6 or 16	10	10	2	2	2	6	16	6
	AC 15	2 4	2 4	2 4	2	2	0,5	0,5	0,5	2	4	2
Contacts gold-coated	DC 12 24 V	6 8	6 8	6 8	4	4	2	2	2	6	8	4
	48 V	2 4	2 4	2 4	2	2	1	1	1	2	4	2
	110 V	0,5 1	0,5 1	0,5 1	0,2	0,2	0,1	0,1	0,1	0,5	1	0,2
	220 V	0,1 0,5	0,1 0,5	0,1 0,5	0,1	0,1				0,1	0,5	0,1
	24 V	5 mA	5 mA	5 mA	5 mA	5 mA	5 mA	5 mA	5 mA	5 mA	5 mA	5 mA
DC 13	24 V	1	1	1	3	3	1,5	1,5	1,5	1	1	3
	48 V	0,5	0,5	0,5	1,5	1,5	0,5	0,5	0,5	0,5	0,5	1,5
	110 V	0,2	0,2	0,2	0,1	0,1	0,05	0,05	0,05	0,2	0,2	0,1
	220 V	0,05	0,05	0,05	0,05	0,05				0,05	0,05	0,05
Short-circuit-protection in Ampere Fuse 9 L Circuit-breaker G-characteristic	6 16		6 16	6 16	10	10	4	4	4	6	16	6
	6 16		6 16	6 16	10	10	4	4	4	6	16	6
Terminal screws Plug-in connection CAGE CLAMP® connection is a registered trademark of WAGO Kontakttechnik GmbH Germany	M 3,5		M 3,5	M 3,5	M 3,5 6,3 x 0,8	M 3,5 6,3 x 0,8	Solder terminal				M 4 6,3 x 0,8	M 3,5 6,3 x 0,8
	2,5 mm ²		2,5 mm ²	2,5 mm ²					1,5 mm ²			
Conductor sizes in mm ² finely stranded with end steeves	1,5		1,5	1,5	1,5	1,5	0,5	0,5	0,5	1	1,5	1,5
Mechanical life in million (operation cycles) max. switching frequency c/h 1000	10		20	10	6	10	8	12	8	6	6	10
Mechanical shock resistance to IEC 68-2-27	Shock-amplitude > 15 Shock duration 20 ms											
Clearances and creepage distances to IEC 947-1; 2.5.46.51	Overvoltage category III pollution grade 3											
Degree of protection to IEC 529 DIN 40050	1. numeral protection of contact and foreign bodies						2. numeral protection of water					
	IP 00 No protection						No protection					
	IP 54 Protection deposits of dust						Protection splashing of water					
	IP 65 Protection complete of dust						Protection hosed of water					
	IP 66 Protection complete of dust						Protection hosed strong of water					

**GESSMANN**

Industrial controllers

W. Gessmann GmbH
 Postfach 11 51
 74207 Leingarten
 Eppinger Straße 221
 74211 Leingarten

Tel. Nat 0 71 31 - 40 67-0
 Fax Nat 0 71 31 - 40 67-10
 Tel. Int +49 71 31 - 40 67-0
 Fax Int +49 71 31 - 40 67-10
 E-mail gessmann@gessmann.com
 Internet www.gessmann.com

5/900

2008

Representatives Federal Republic of Germany

I.K.F. Ingenieur- und Vertriebsbüro K. Falk
 An der Strusbek 8 D
 22926 Ahrensburg
 Phone 0 41 02 / 21 13-0
 Fax 0 41 02 / 21 13-10
 E-mail info@ikfgmbh.de
 Internet www.ikfgmbh.de

Bretzel GmbH
 Postfach 51 67, 65726 Eschborn
 Industriestraße 9, 65760 Eschborn
 Phone 0 61 96 / 40 31 90
 Fax 0 61 96 / 4 30 47
 E-mail info@bretzel-gmbh.de
 Internet www.bretzel-gmbh.de

Christiani Elektro-Vertriebs-GmbH
 Innungstraße 39
 50354 Hürth
 Phone 0 22 33 / 3 50 35
 Fax 0 22 33 / 3 61 81
 E-mail vertrieb@christiani-gmbh.de
 Internet www.christiani-gmbh.de

Udo Schramm Büro für Elektrotechnik
 Benninghofer Straße 284
 44267 Dortmund
 Phone 02 31 / 46 40 39
 Fax 02 31 / 4 71 70
 E-mail schramm-dortmund@t-online.de

Dipl. Ing. H. Ch. Adlung & Co.
 Hüttenstraße 16
 01979 Lauchhammer-Ost
 Phone 0 35 74 / 8 65 53
 Fax 0 35 74 / 8 65 86
 E-mail iba-adlung@t-online.de

Dr.-Ing. Klaus Zimmermann Ingenieurbüro
 Hauptstraße 15
 06493 Neudorf (Harz)
 Phone 03 94 84 / 63 64
 Fax 03 94 84 / 63 19
 E-mail ib-zimmermann@gmx.de

Germany



Representatives foreign country

AE Cavotec Middle East FZE
United P.O.Box 61 124
Arab Jebel Ali Free Zone, AA2 & AA3-RA08
Emirates Dubai
Phone +971 488 38 350
Fax +971 488 38 352
E-mail daniel.lexander@cavotec.com
Internet www.cavotec.com

AR Cavotec Latin America S.A
Argentina Acassuso 548
(1642) San Isidro
Buenos Aires
Phone +54-11 4743 7049
Fax +54-11 4743 9914
E-mail marcelo.gonzalez@cavotec.com
Internet www.cavotec.com

AU Cavotec Australia Pty Ltd.
Australia Head Office Newcastle
Postfach 577
28 Mitchell Road, Cardiff NSW 2285
Phone +61-2 49 / 56 57 88
Fax +61-2 49 / 56 58 23
E-mail phillip.macridis@cavotec.com
Internet www.cavotec.com

BE HPR Technik
Belgium Leuvensesteenweg 613
1930 Zaventem zuid 7
Phone +32 225 33 120
Fax +32 225 30 897
E-mail info@hprtechnik.com
Internet www.hprtechnik.com

BR Choice Tecnologia Ind.e Com.de
Brazil equipamentos industriais Ltda
Curupaitis Street, 88851
Santa Quitéria PO 80310180
Curitiba City Parana State, Brazil
Phone +55 041 301 579 53
Fax +55 041 301 578 53
E-mail flavio@choicetecnologia.com.br
Internet www.choicetecnologia.com.br

CA SENETT Control Co. Ltd.
Canada 225 Admiral BLVD.
Mississauga Ontario L5T2T3
Phone +1-9 05 / 5 64 01 67
Fax +1-9 05 / 5 64 66 33
E-mail senett@ica.net
Internet www.senett.ca

CH ELVA AG - Elektrische Verteilanlagen
Switzerland Werbhollenstrasse 54
4143 Dornach 2
Phone +41-61 / 7 06 85 95
Fax +41-61 / 7 06 85 91
E-mail info@elva.ch
Internet www.elva.ch

CN W. Gessmann GmbH
China Shanghai Regional Office
German Center
Room 310, Tower 1
88 Keyuan Road, Pudong
Shanghai 201203
Phone +86 21 28 98 63 09
Fax +86 21 28 98 62 12
E-mail hou@gessmann.com
Internet www.gessmann.com

Cavotec Shanghai Ltd.
Shanghai, China
Xinzhuang Industrial Zone Minhang District
Unit 3, No.879 ShenFu Road
Shanghai 201108
Phone +86 21 54 42 97 78
Fax +86 21 34 07 34 98
E-mail phileas@cavotec.com.cn
Internet www.cavotec.com

CZ ELPRO Drive, s.r.o.
Czech uL. Miru3
Republic 73961 Trinec
Phone +42 0 558 338 040
Fax +42 0 558 338 042
E-mail agorgol@elprodrive.cz
Internet www.elprodrive.cz

DK Ib Baastrup A/S
Denmark Dronning Olgas Vej 30
2000 Frederiksberg
Phone +45-38 / 10 21 29
Fax +45-38 / 10 29 69
E-mail info@baastrup.com
Internet www.baastrup.com

FI Kentek Oy
Finland Postbox 18, 01721 Vantaa
Tiilenlyöjänkuja 4, 01720 Vantaa
Phone +3 58-9 / 8 49 42 00
Fax +3 58-9 / 84 94 20 59
E-mail kentek@kentek.fi
Internet www.kentek.fi

FR Bureau Gessmann France
France Jean-Louis Guiraud
18, rue des Verges
67110 Niederbronn-Les-Bains
Phone +33-3 / 69 16 90 18
Fax +33-3 / 69 16 90 18
E-mail guiraud@gessmann.com
Internet www.gessmann.com

GB Cavotec UK Ltd.
United Market Deeping
Kingdom Stirling Way, Lincolnshire PE 8AS
Phone +44-17 78 / 34 67 69
Fax +44-17 78 / 34 18 50
E-mail hans.winemar@cavotec.com
Internet www.cavotec.com

GR Stefanidou Kalliopi
Greece Agios Dimitrios
P.O. Box 203
50100 Kozani
Phone +30-30 2 46 10 / 9 44 45
Fax +30-30 2 46 10 / 9 44 25
E-mail kastefa@otenet.gr

HK Cavotec Hongkong LTD.
Hong Kong Unit 1103 Skyline Commercial Centre,
71-77 Wing Lok Street,
Sheung Wan, HongKong
Tel: +852 2791 6161
Fax: +852 2791 1834
E-mail:phileas@cavotec.com.cn
Internet www.cavotec.com

IT S.P.I.I. Società per Azioni
Italy Via Volpi, 37, 21047 Saronno VA
Phone +39-02 / 9 62 29 21
Fax +39-02 / 9 60 96 11
E-mail info@spii.it
Internet www.spii.it

IN Arihant Systems & Electricals P Limited
India Sheel Tara House
24/4866 Ansari Road Daryaganj
New Delhi - 110002
Phone +91-11-23 26 90 11
Fax +91-11-23 27 35 54
E-mail info@arihantelectricals.com
Internet www.arihantelectricals.com

JP Hiroyuki Niiya
Japan 3-13-10 Myojin
Oji Kitakatsuragi-Gun, Nara
636-0022, Japan
Phone +81 (0) 745 32 4020
Fax +81 (0) 745 32 4020
E-mail h.niiya@krc.biglobe.ne.jp

KR Tha Kyung Metronics Inc.
Korea 1231 LG-ECLAT
736-24 YUKSAM-DONG
KANGNAM-KU, Seoul
Phone +822-568-6534
Fax +822-568-6535
E-mail thakyung@unitel.co.kr

MX Alimentaciones Electricas S.A. DEC.V
Mexico Col. Corredor Empresarial, Guantlancingo
Rio Suchiate No. 24
CP 72700 Puebla Pue
Phone +52-222 / 210 50 93
Fax +52-222 / 210 50 69
E-mail almesa@mexis.com
Internet www.almesa.com.mx

NO Cavotec Norge, AS
Norway Box 838, 3007 Drammen
Rosenkrantzgt 75, 3018 Drammen
Phone +47-32 / 26 45 00
Fax +47-32 / 26 91 50
E-mail info@cavotec.no
Internet www.cavotec.com

NL HPR Technik BV
Netherlands Postfach 9393, 3007AJ Rotterdam
Stolwijkstraat 33, 3079 DN Rotterdam
Phone +31 10 / 2 92 87 87
Fax +31 10 / 2 92 87 65
E-mail info@hprtechnik.nl
Internet www.hprtechnik.nl

PL ELEKTRO-TRADING
Poland ul.P.Gojawiczynskiej 13
44-109 Gliwice, Poland
Phone +48-32 / 330 45 70
Fax +48-32 / 330 45 74
E-mail et@elektro-trading.com.pl
Internet www.elektro-trading.com.pl

RCL Integration de Sistemas S.A.
Chile San Nicolas 1135
San Miquel-Santiago
Phone +56 2 2523 1863
Fax +56 2 2522 4033
E-mail alorca@io.cl
Internet www.io.cl

RO ELECTRO-DISTRIBUTION S.R.L.
Romania Str. mecet nr. 42-44, sector 2
Bucuresti
Phone +40-21-2 53 29 55
Fax +40-21-2 53 29 56
E-mail anca.mohonea@electrodistribution.ro
Internet www.electrodistribution.ro

SE Kiepe Elektriska AB
Sweden Lodgatan 4, 21124 Malmö
Phone +46-40 / 29 15 55
Fax +46-40 / 29 12 31
E-mail kiepe@kiepe.se
Internet www.kiepe.se

SG My Port (M) SDN BHD
Singapore #04-01/03, 4th Floor, Wisma PTP, Block B
Jalan Pelabuhan Tanjung Pelepas
Gelang Patah 81560
Johor Darul Takzim

TH MY
Thailand Phone +60-7-50 71 799
Fax +60-7-50 71 798
E-mail arfah@my-port.net
Internet www.my-port.net

ID Arda Makina Elektrik
Indonesia Ticaret ve Sanayi Ltd. Sirketi
Sanayi Cad Dogan Sok. No. 1/C
Ulus / Ankara
Phone +90 312 3 09 12 37
Fax +90 312 3 10 13 53
E-mail arda@ardaelektrik.com
Internet www.ardaelektrik.com

TR OEM Controls, inc.
Turkey 10 Controls Drive
Shelton, Conn. 06484
Phone +1-2 03 / 9 29-84 31
Fax +1-2 03 / 9 26-69 24
E-mail ksmons@oemcontrols.com
Internet www.oemcontrols.com

US Cavotec Gantrex Inc.
United 124 Hatfield Road
States Statesville, NC 28625
Phone +1-7 04-8 73-30 09
Fax +1-7 04-8 73-30 93
E-mail erik.wilhelmsen@cavotec.com
Internet www.cavotec.us

YU TGT Veljka Vlahovića 34
Yugoslavia YU-11550 Lazarevac
Phone +381-11-8122-665
Fax +381-11-8120-555
E-mail vidicb@EUnet.yu

ZA Powermite House
South Afrika P.O.Box 7745, Johannesburg 2000
92, Main Reef Road
Technikon Roodeport
Phone +27-11-2 71-00 00
Fax +27-11-7 60-30 99
E-mail Powermite.jhb@global.co.za
Internet www.powermite.co.za