

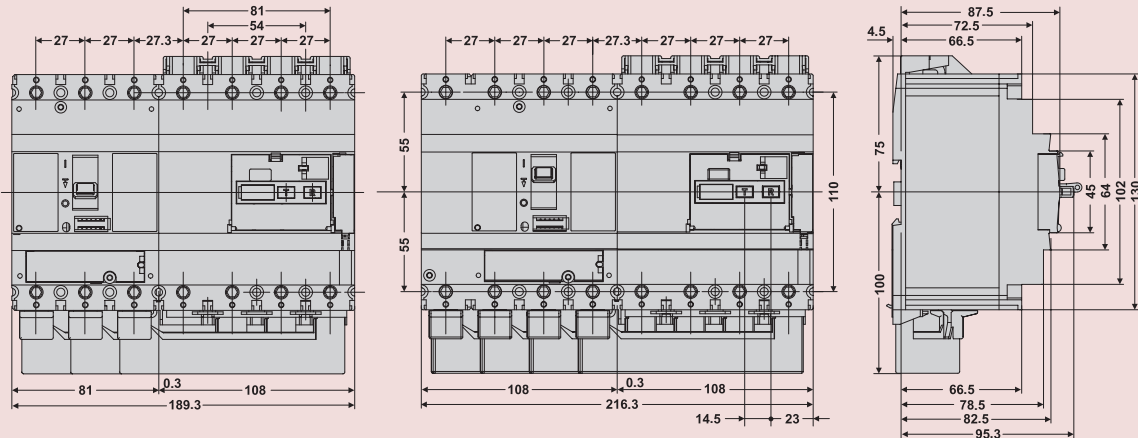

# Dimensional Drawings

## RCD side mounted - FD63/160



## Breakers with phase separator - FD and FE frames

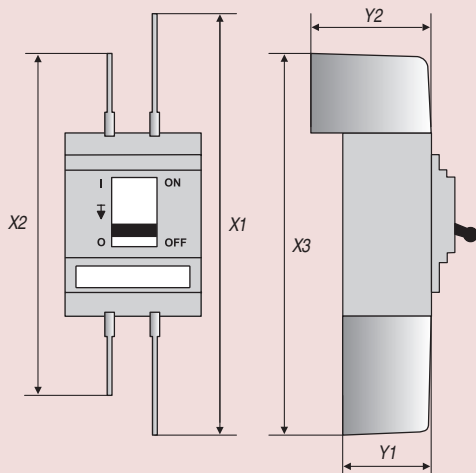

Dimensions		
	FD63 FD160	FE160 FE250
X1	330	410
X2	245	304
X3	287,5	357
Y1	63	72,5
Y2	105,5	126





# Dimensional Drawings

## Breakers with electrical operator - FD63/160

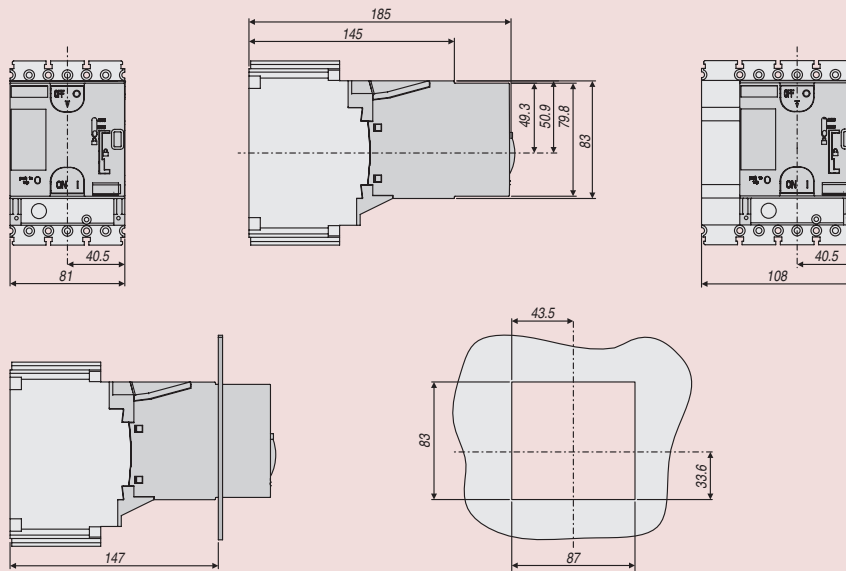

## Breakers with electrical operator - FE160 and FE250

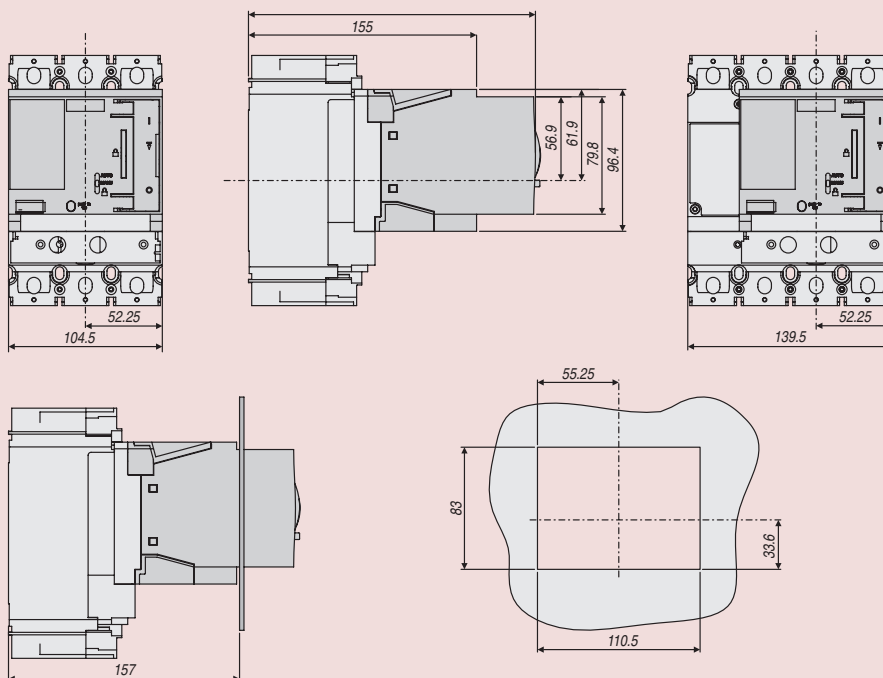

Dimensional Drawings

Rotary handle - Breaker and through panel mounted - FD63/160

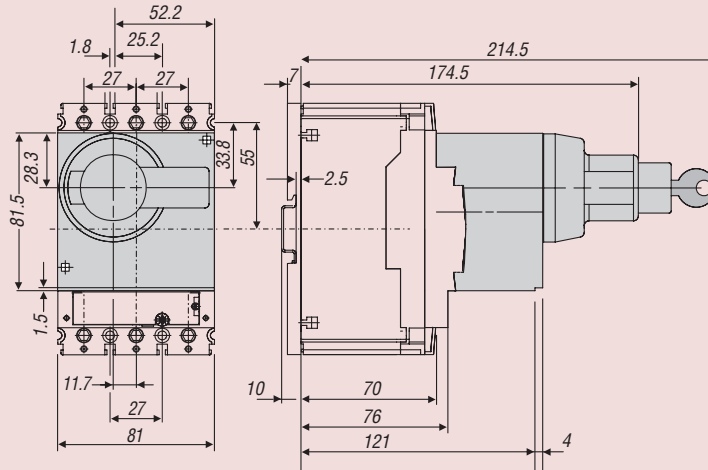

Rotary handle - Breaker and through panel mounted - FE160 and FE250

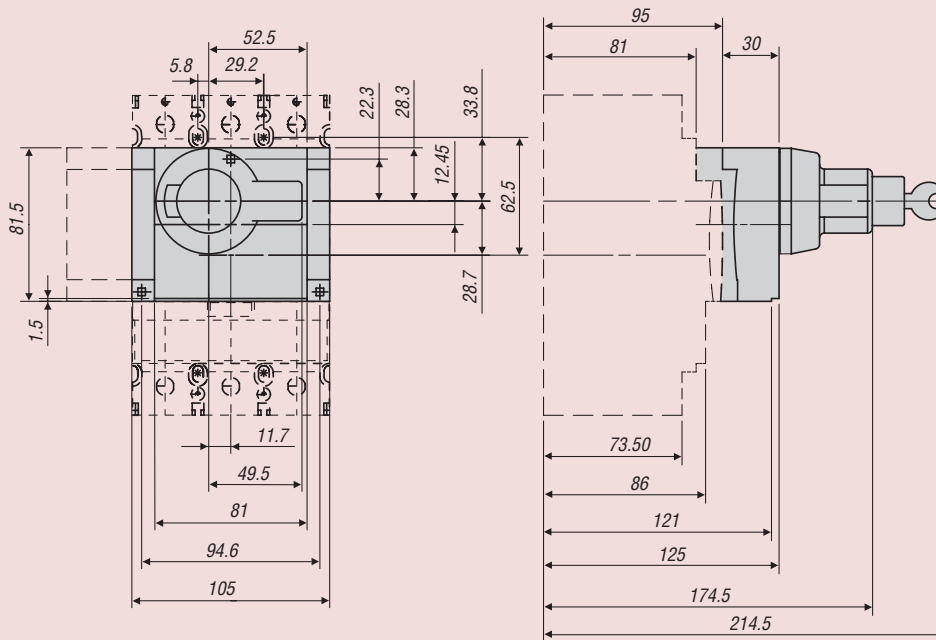

# Dimensional Drawings

## Rotary handle - Door mounted FD63/160

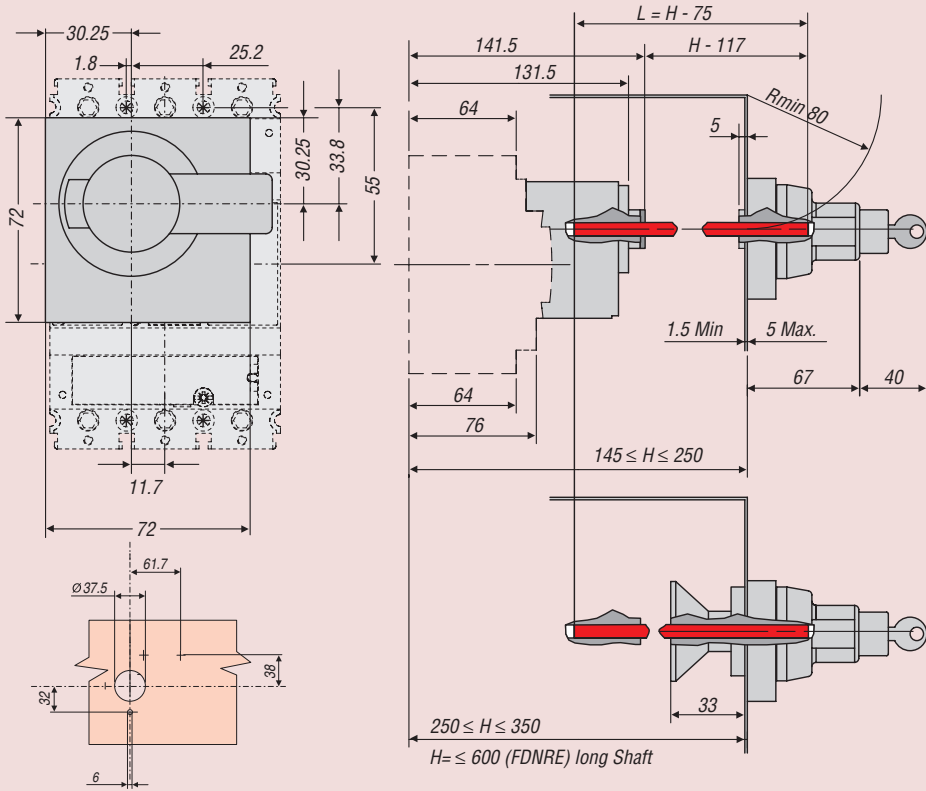

## Rotary handle - Door mounted - FE 160 and FE250

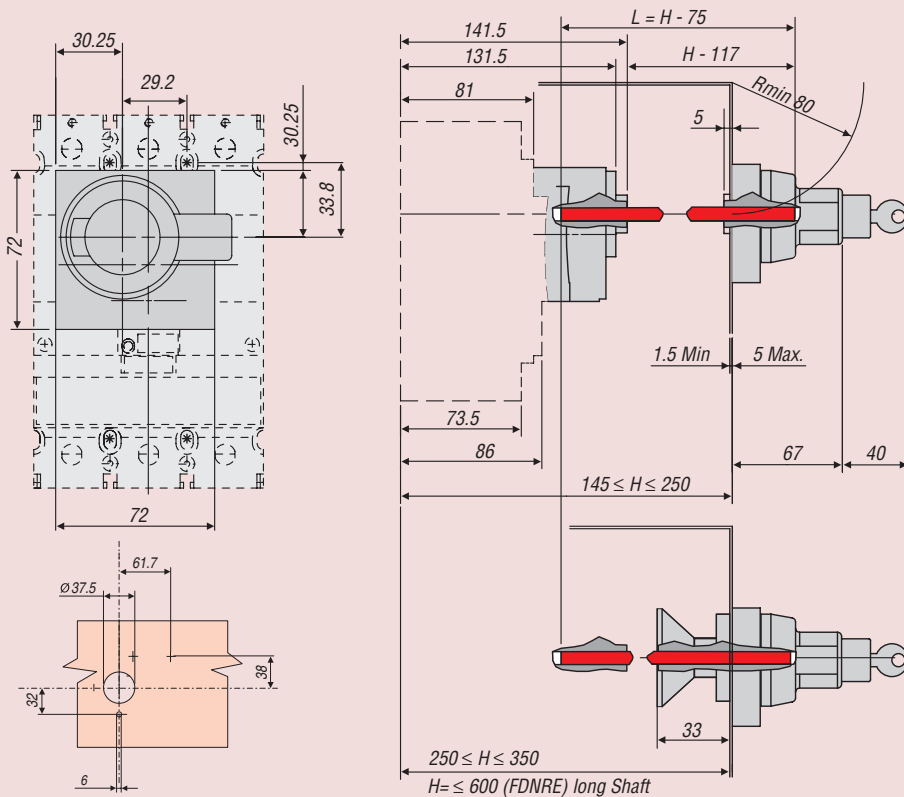

Dimensional Drawings

Plug-in version - FD63/160

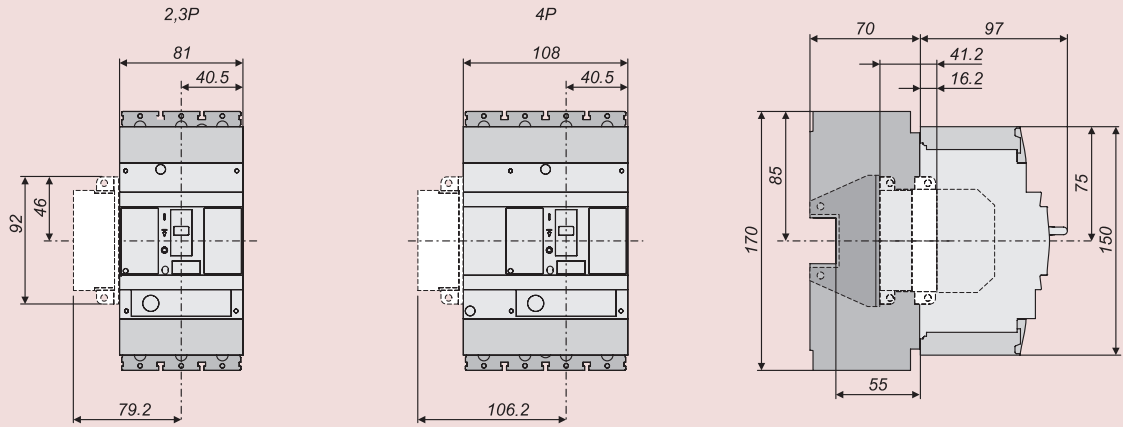

Plug-in version - FE160 and FE250

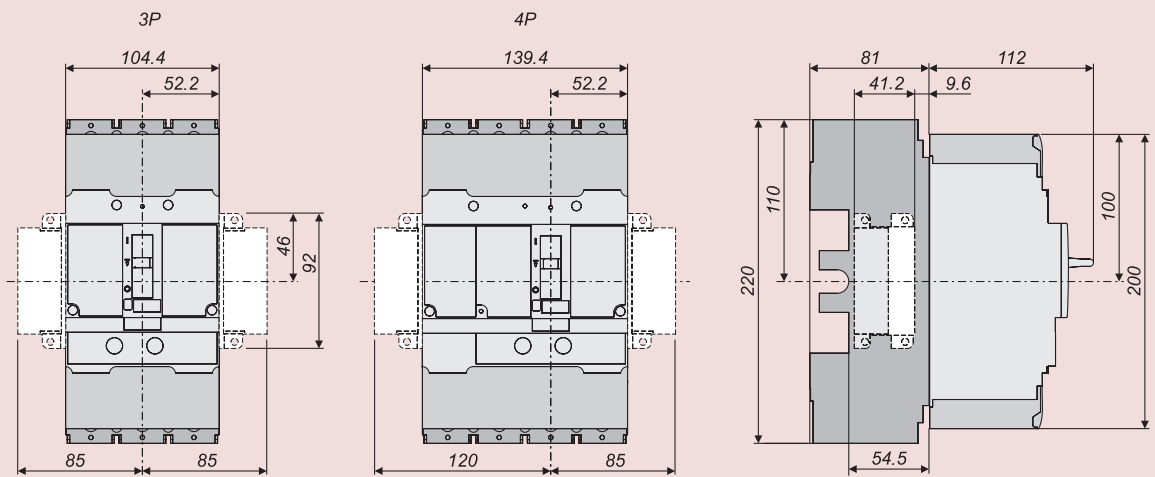

# Dimensional Drawings

## Drawout version - FE160 and FE250

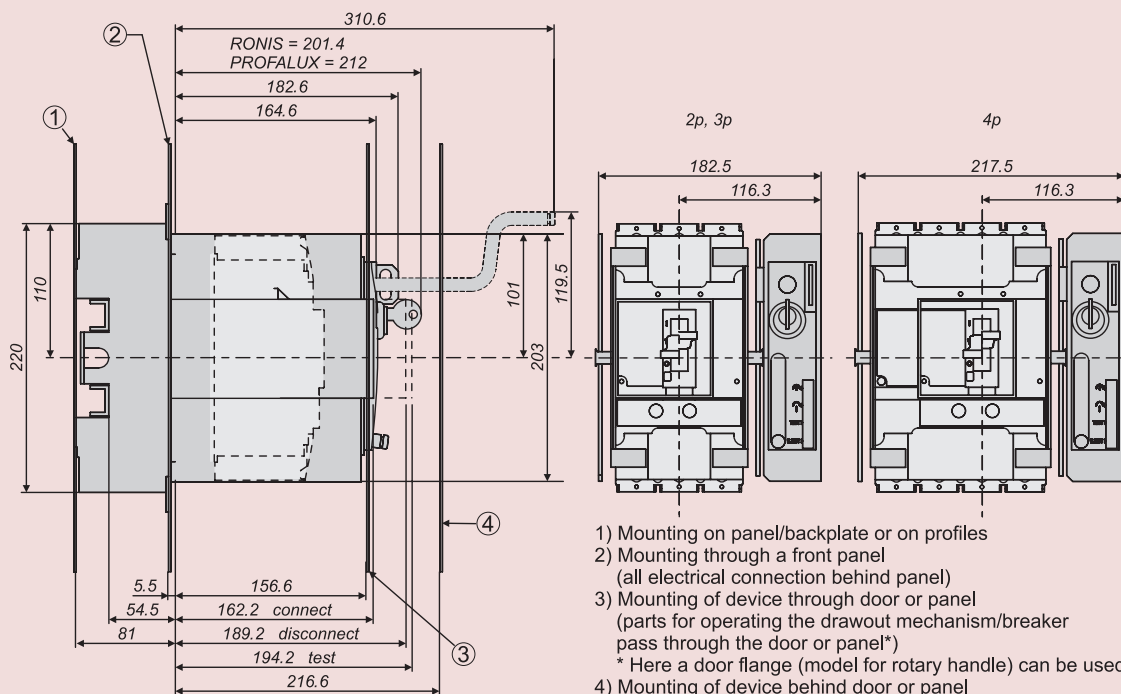

- 1) Mounting on panel/backplate or on profiles
- 2) Mounting through a front panel  
(all electrical connection behind panel)
- 3) Mounting of device through door or panel  
(parts for operating the drawout mechanism/breaker pass through the door or panel\*)  
\* Here a door flange (model for rotary handle) can be used
- 4) Mounting of device behind door or panel  
(all parts for operating the drawout mechanism/breaker behind the door or panel)





## Dimensional Drawings

### Door flanges - FD63/160, FE160 and FE250

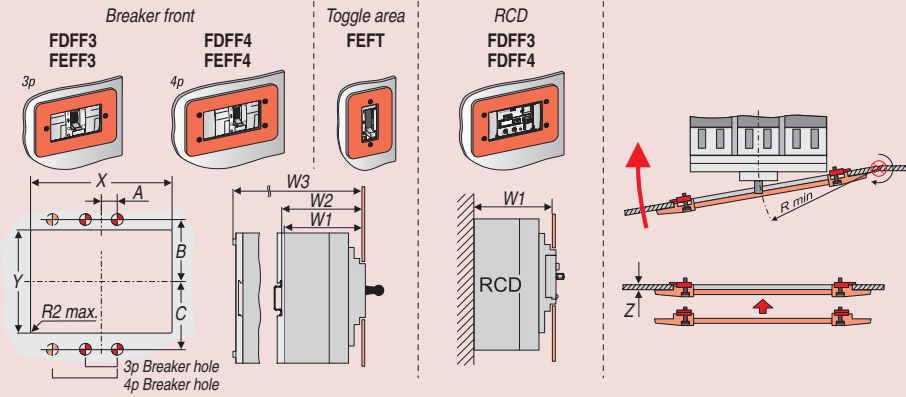

			Dimensions									
			A	B	C	Rmin	W1(max)	W2(max)	W3(max)	X	Y	Z
FDFF3	FD 63/160	3p	13,5	55	55	80	83,2	85,8	93,2	114	78	1...4
FDFF4	FD 63/160	4p	13,5	55	55	93,5	83,2	85,8	93,2	146	78	1...4
FEFF3	FE 160/250	3p	17,5	55,5	70,5	91,75	89,2	-	-	138	97	1...4
FEFF4	FE 160/250	4p	17,5	55,5	70,5	102,5	89,2	-	-	173	97	1...4
FEFT	FE 160/250	3p/4p	17,5	55,5	70,5	93,5	93,2	-	-	60	97	1...4
FDFF3 (RCD*)	FD 63/160	3p	13,5	155	42	80	83,2	85,8	93,2	114	78	1...4
FDFF4 (RCD*)	FD 63/160	4p	13,5	155	42	93,5	83,2	85,8	93,2	146	78	1...4
FDFF3 (RCD*)	FE 160/250	3p/4p	18	182,1	42	80	89,2	-	-	114	78	1...4

### Door flanges - FD63/160, FE160 and FE250

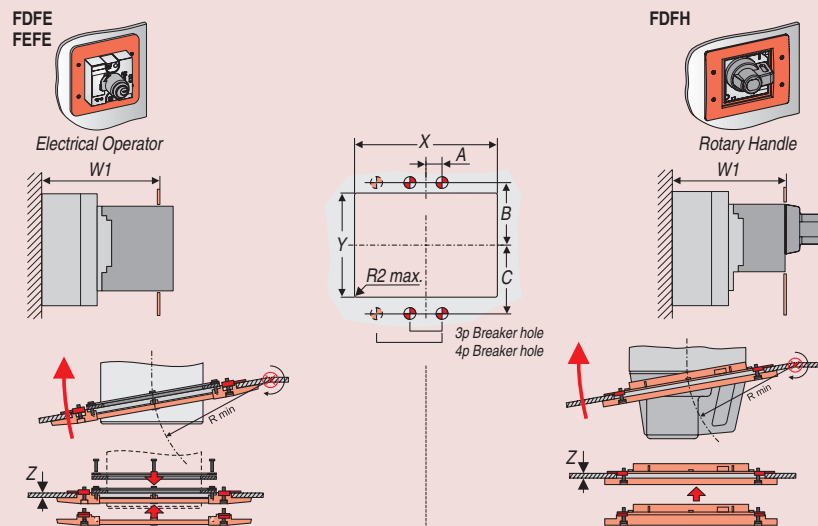

			Dimensions								
3+4 pole versions			A	B	C	Rmin	W1(max)	X	Y	Z	
FDFF	FD 63/160	Electr. Operator	13.5	49.5	64.5	80	141	148.5	124.5	1...4	
FEFF	FE 160/250	Electr. Operator	17.5	46	80	100	170	172	124.5	1...4	
FDFF	FD 63/160	Rotary Handle	13.5	46,25	63.75	100	125	120	120	1...4	
FEFF	FE 160/250	Rotary Handle	17.5	46.25	81.75	100	125	120	120	1...4	

# Dimensional Drawings

## Padlock fixed - FD63/160

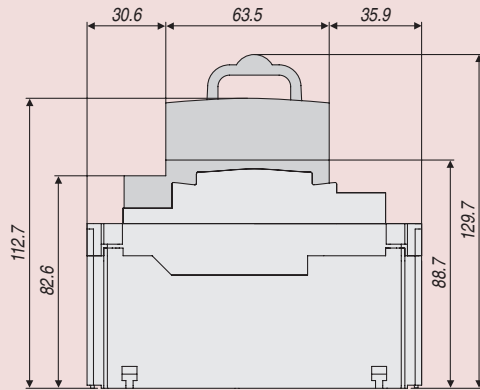

## Padlock fixed - FE160 and FE250

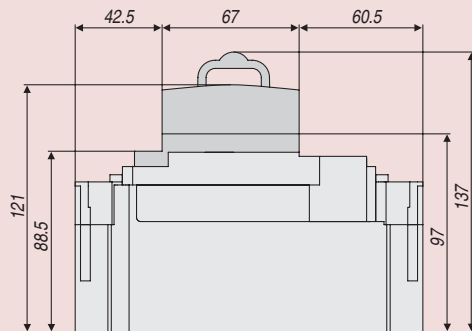

Dimensional Drawings

Back plate - FD63/160

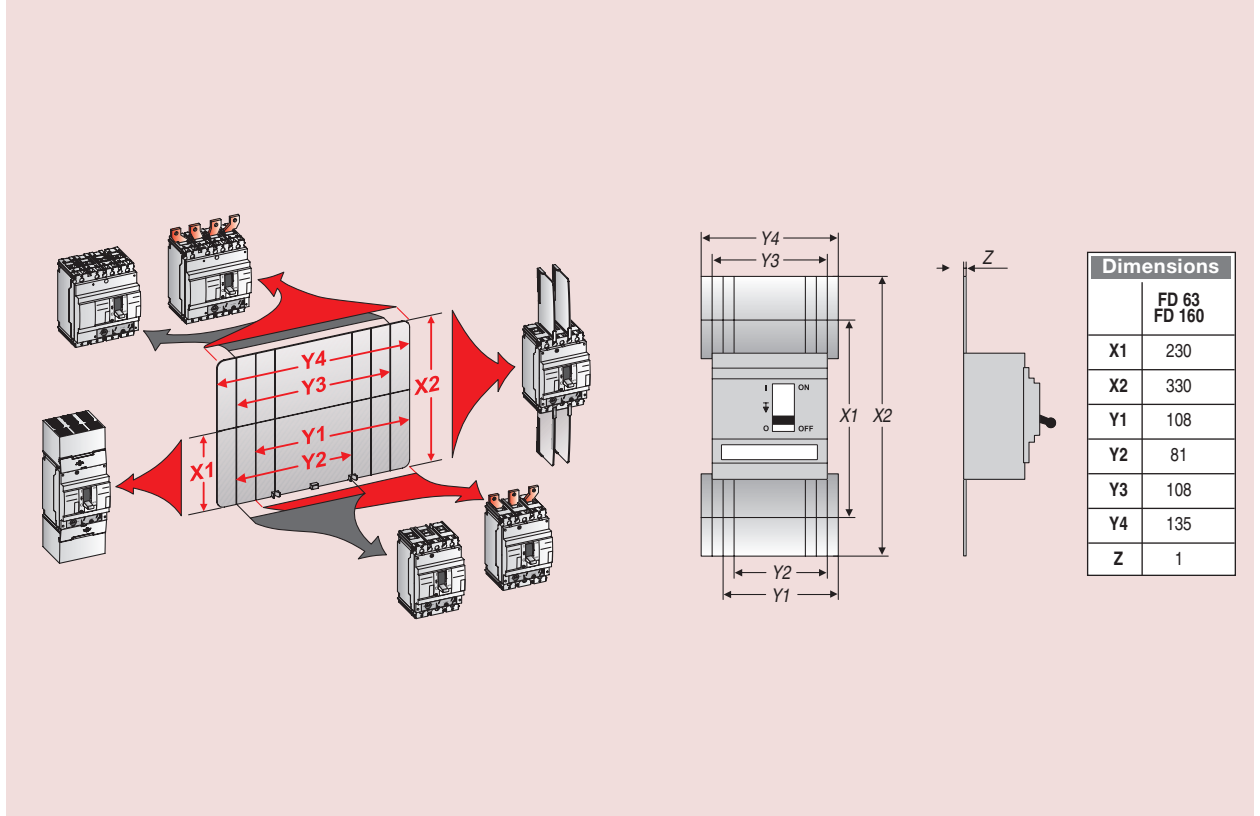

Backplate - FE160 and FE250

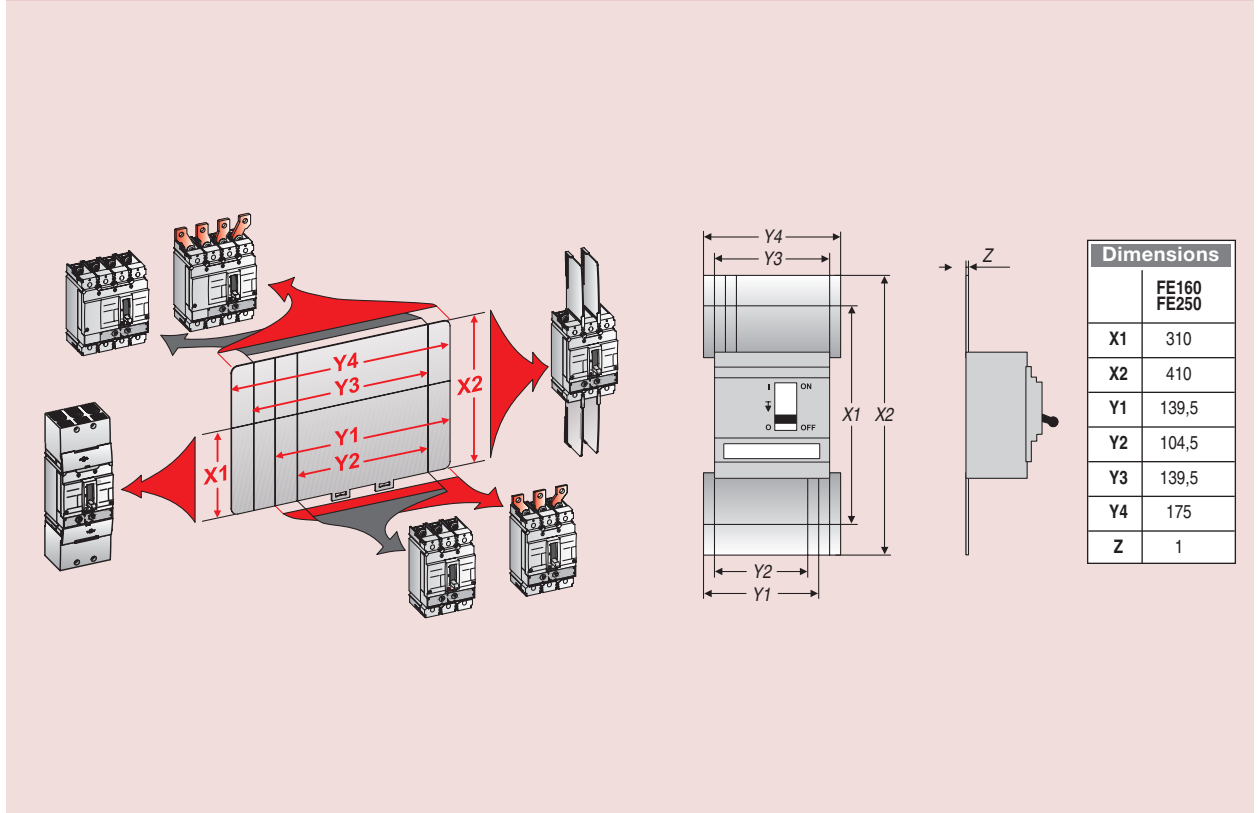

# Dimensional Drawings

## Breaker with short terminal shields - FD63/160

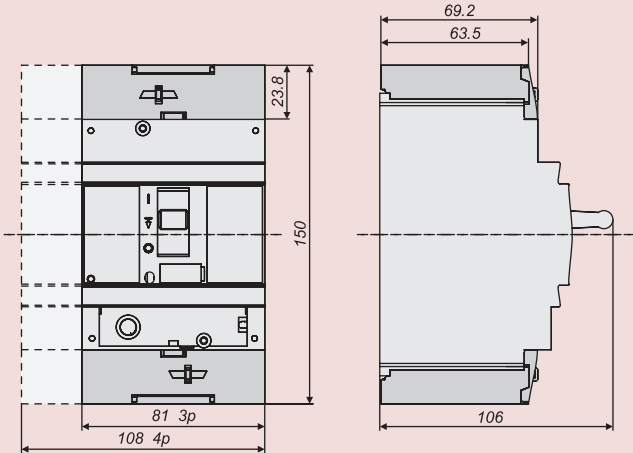

## Breaker with long terminal shields - FD63/160

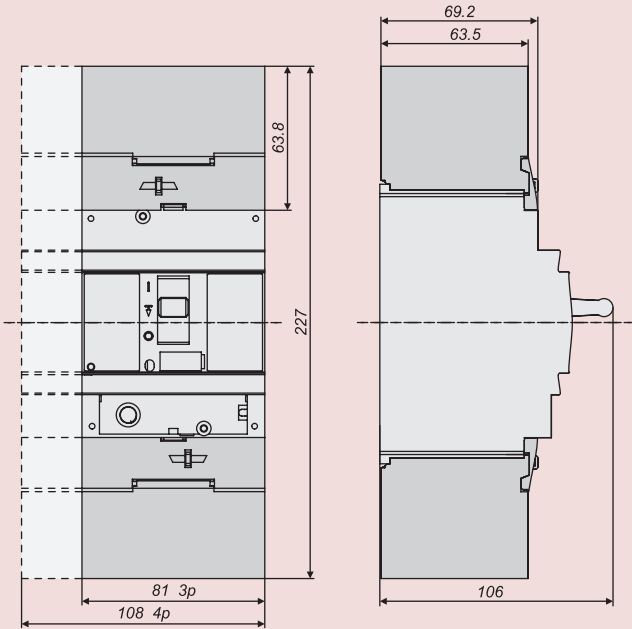

**Dimensional Drawings**

Dimensions

**Breaker with short terminal shields - FE160 and FE250**

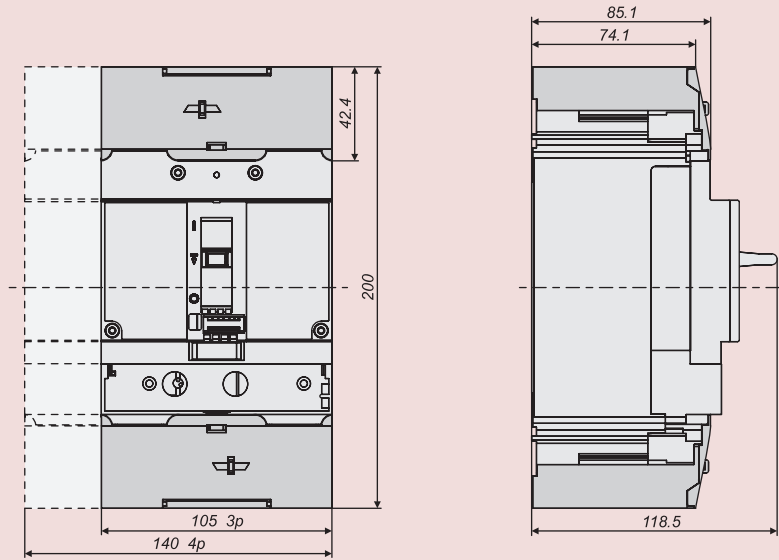

**Breaker with long terminal shields - FE160 and FE250**

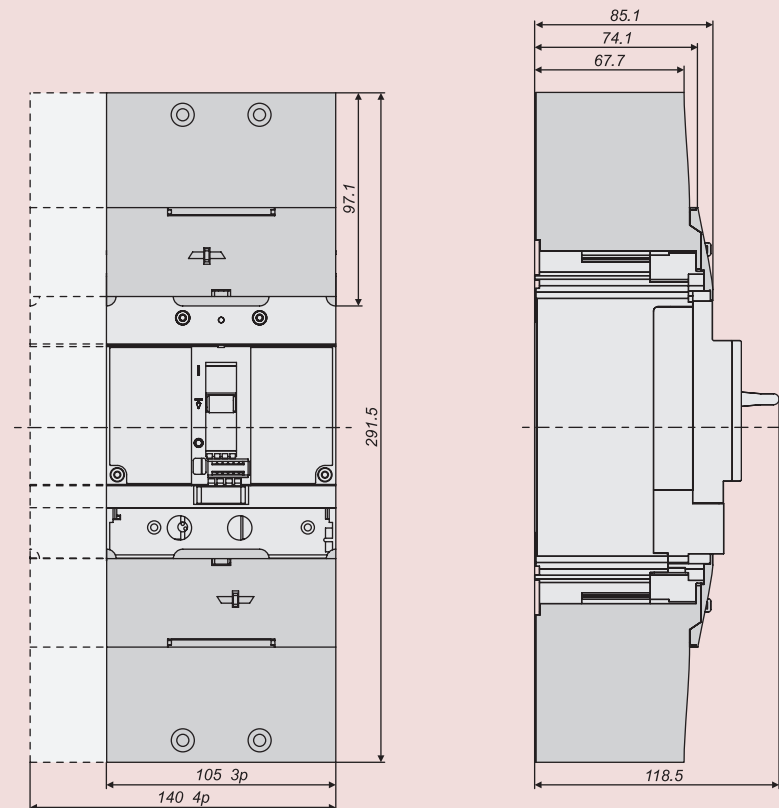

G





## Dimensional Drawings

### Breaker with electrical operator - FG400/630

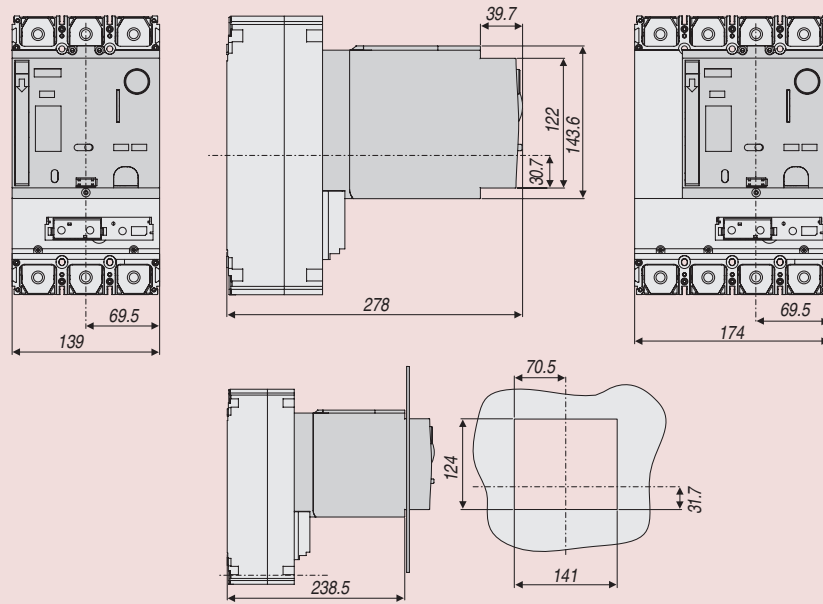





Dimensional Drawings

Plug-in version - FG400/630

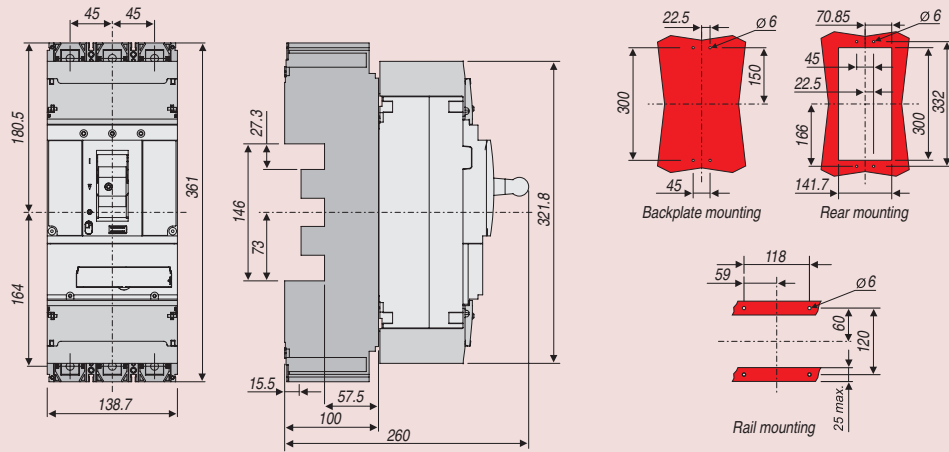

Drawout version - FG400/630

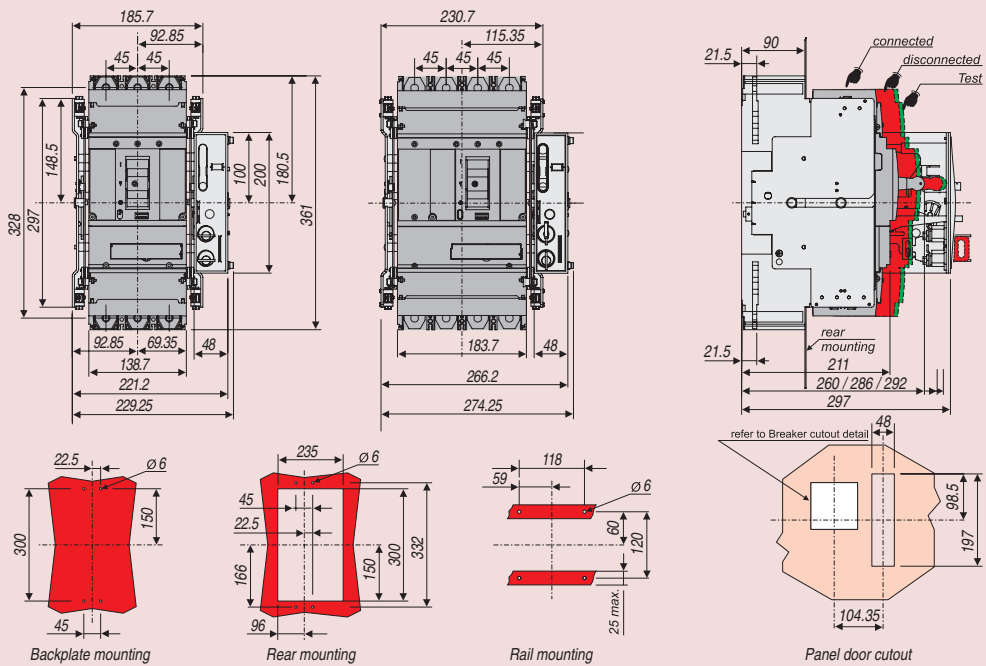

# Dimensional Drawings

## Door flanges - FG400/630

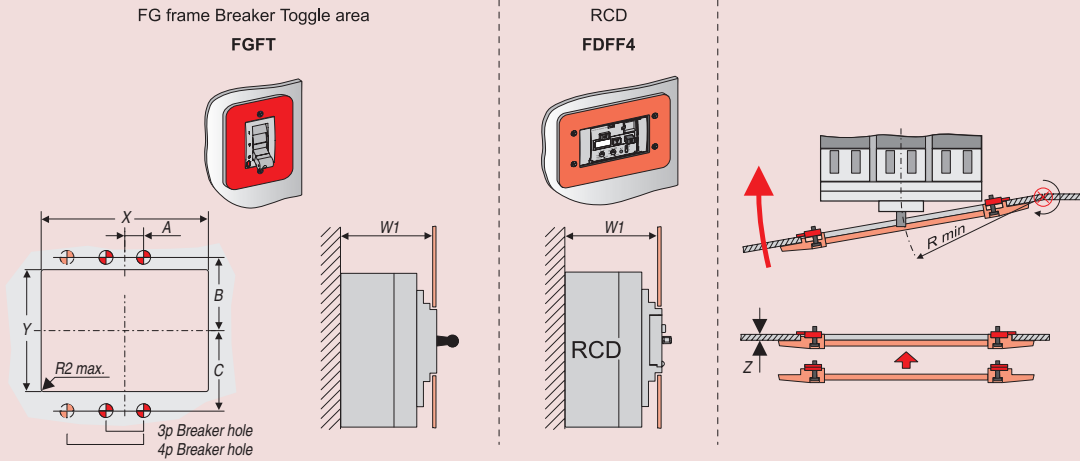

		Dimensions								
			A	B	C	Rmin	W1(max)	X	Y	Z
FGFT	FG 400/630 Toggle	3p/4p	22.5	73	127	100	115	95	135	1...4
FDFF4	FG 400/630 RCD	3p/4p	22.5	297.5	68.5	93.5	115	146	78	1...4

## Door flanges - FG400/630

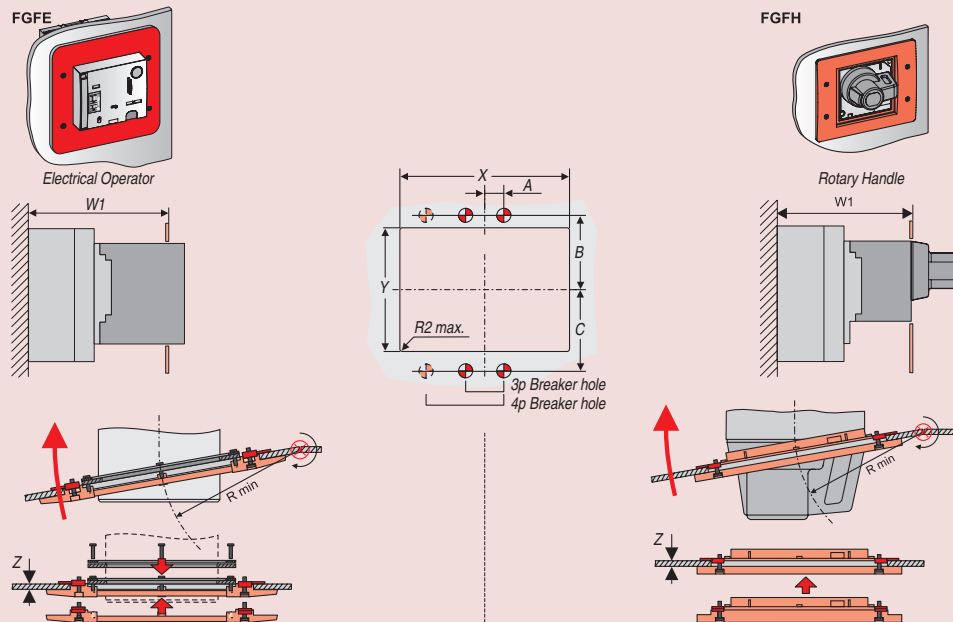

		Dimensions								
			A	B	C	Rmin	W1(max)	X	Y	Z
FGFE	FG 400/630 Electr. Operator	3+4 pole versions	70.5	85	145	100	238.5	41	126	1...4
FG FH	FG 400/630 Rotary Handle		22.5	72.5	129	115	161	191	181.5	1...4



Dimensional Drawings

Dimensions

Padlock fixed - FG400/630

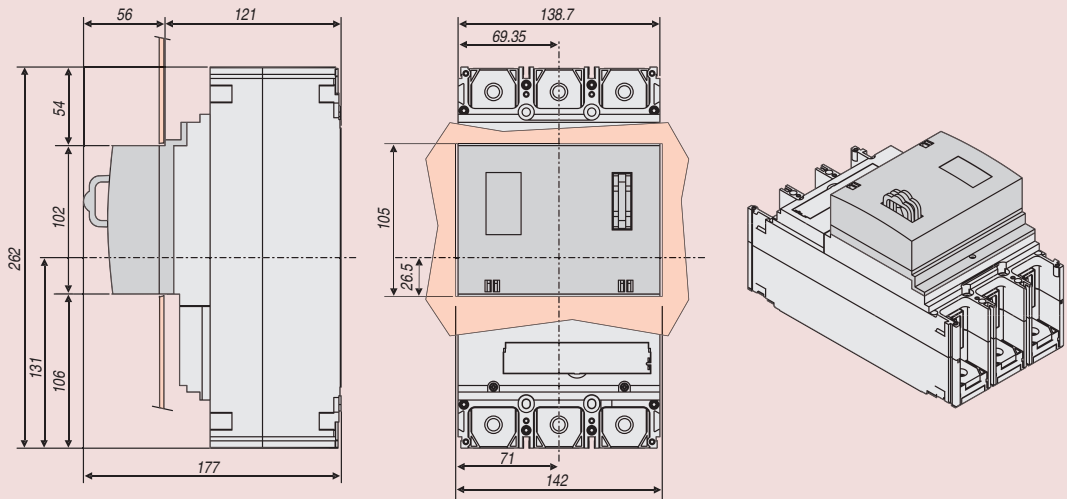

Backplate - FG400/630

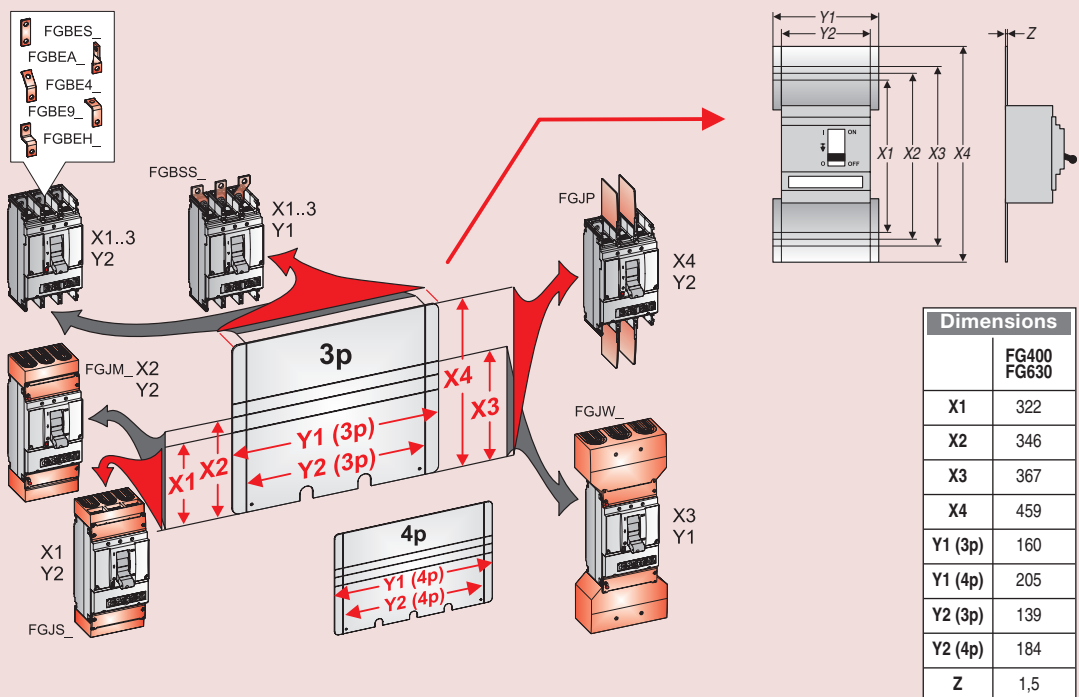

G



# Dimensional Drawings

## Breaker with short terminal shields - FG400/630

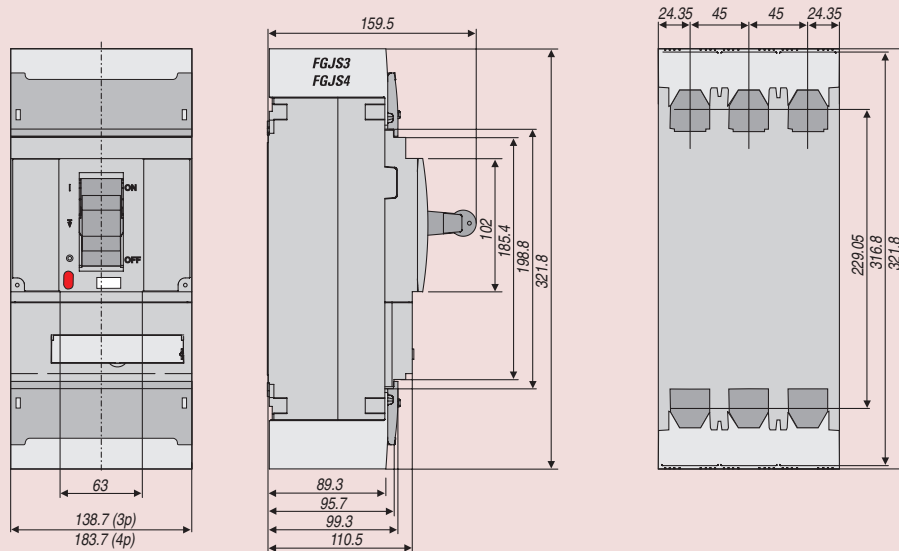

## Breaker with medium terminal shields - FG400/630

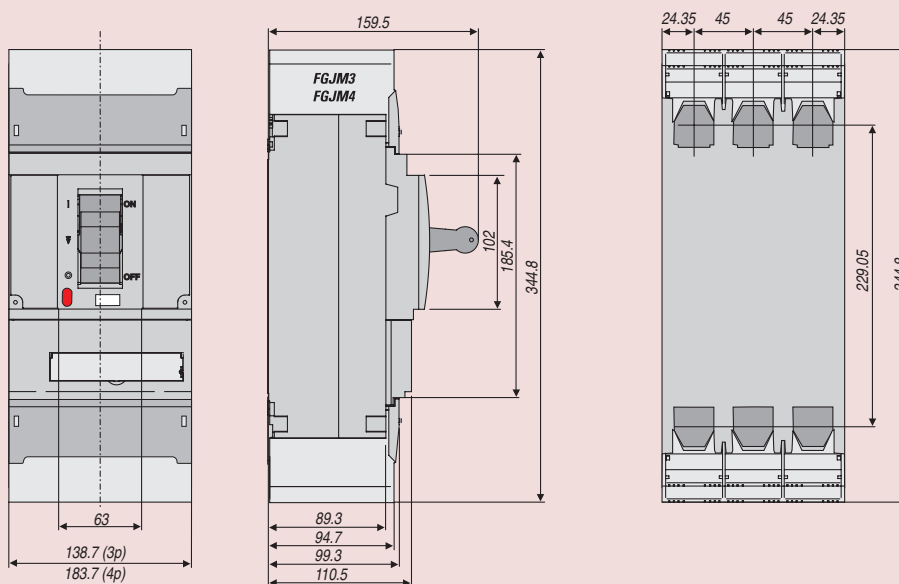

***Dimensional Drawings***

***Breaker with long and wide terminal shields - FG400/630***



Dimensions

G



# Dimensional Drawings

## Breakers - FK800/1250/1600 fixed, front connected

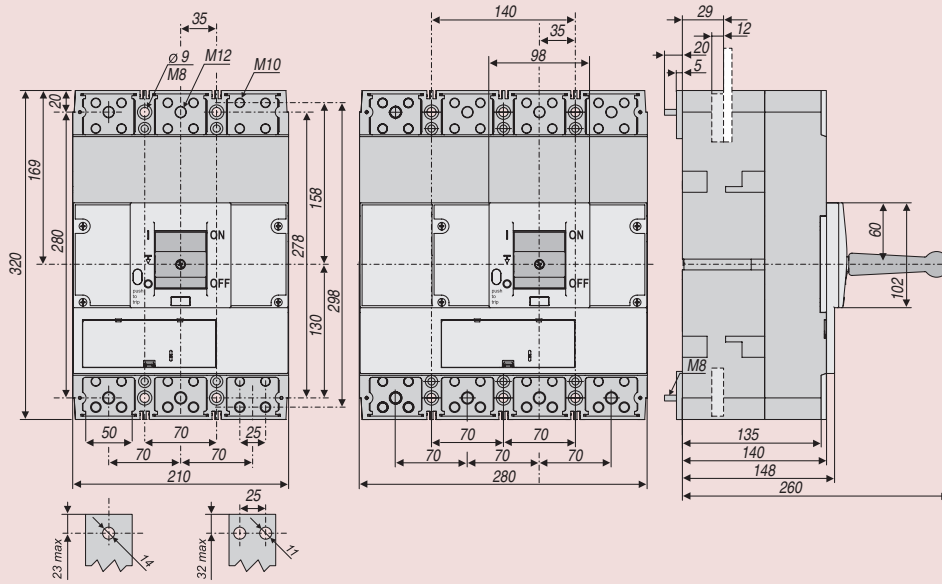

## Breaker with electrical operator - FK800/1250/1600

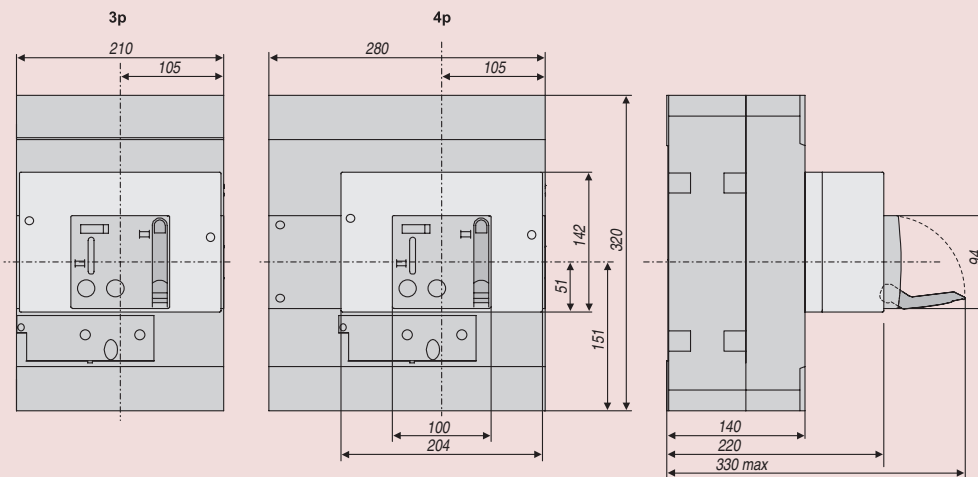

Dimensional Drawings

Rotary handle, door mounted - FK800/1250/1600

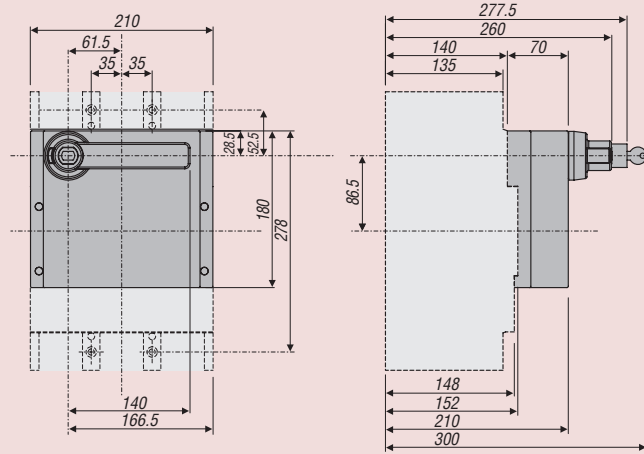

Rotary handle, breaker and through panel mounted - FK800/1250/1600

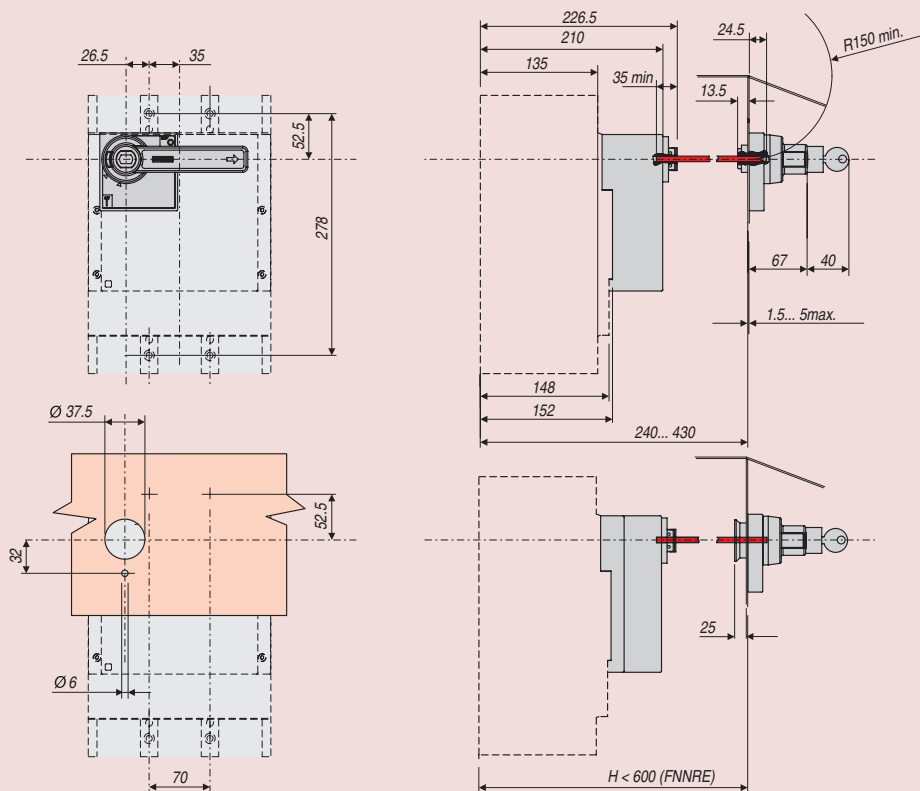

# Dimensional Drawings

## Drawout version - FK800/1250/1600

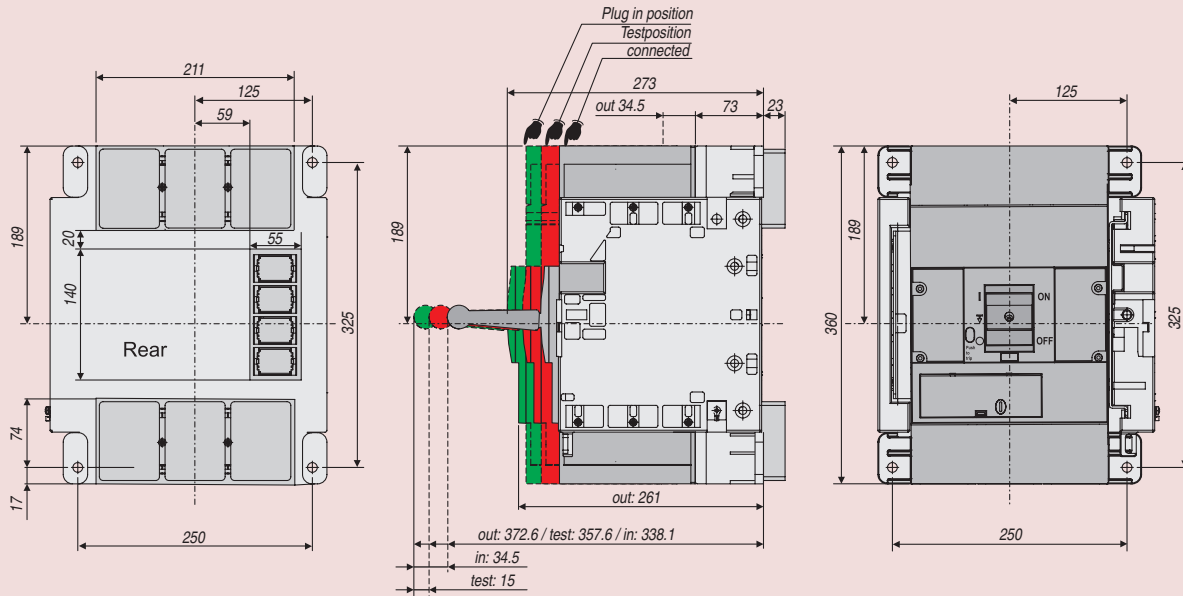

## Breakers with phase separator - FG and FK frames

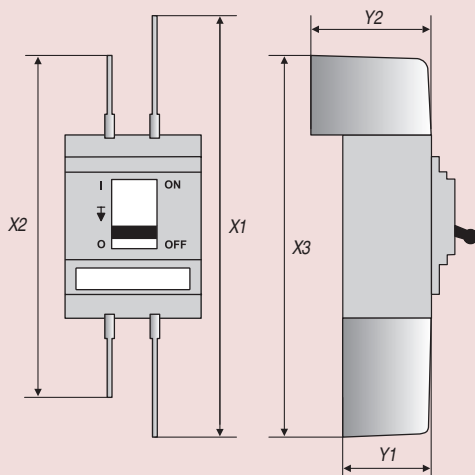

Dimensions		
	FG 400 FG 630	FK 800 FK 1250 FK 1600
X1	459	484
X2	-	-
X3	-	-
Y1	90	135
Y2	-	-



Dimensional Drawings

Door flanges - FK800/1250/1600

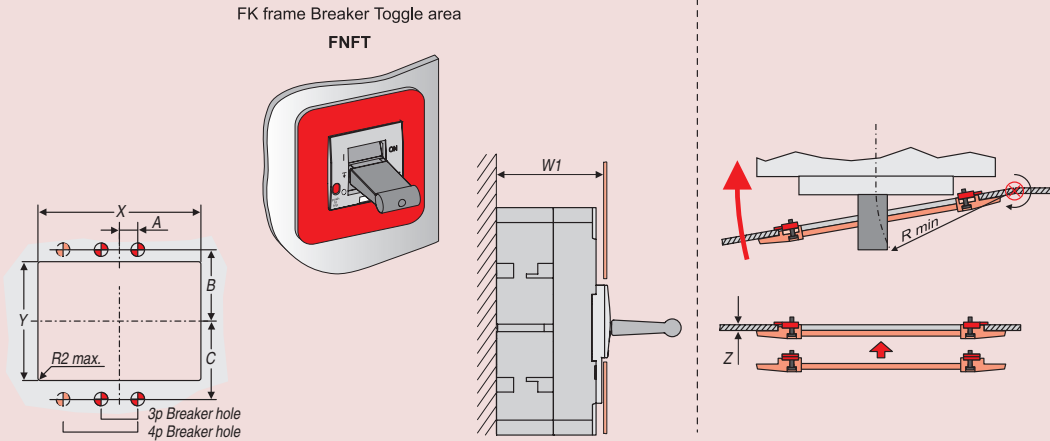

Dimensions										
			A	B	C	Rmin	W1(max)	X	Y	Z
FNFT	FK 800/1250/1600	3p/4p	35	130	150	120	153	101	104	1...4

Door flanges - FK800/1250/1600

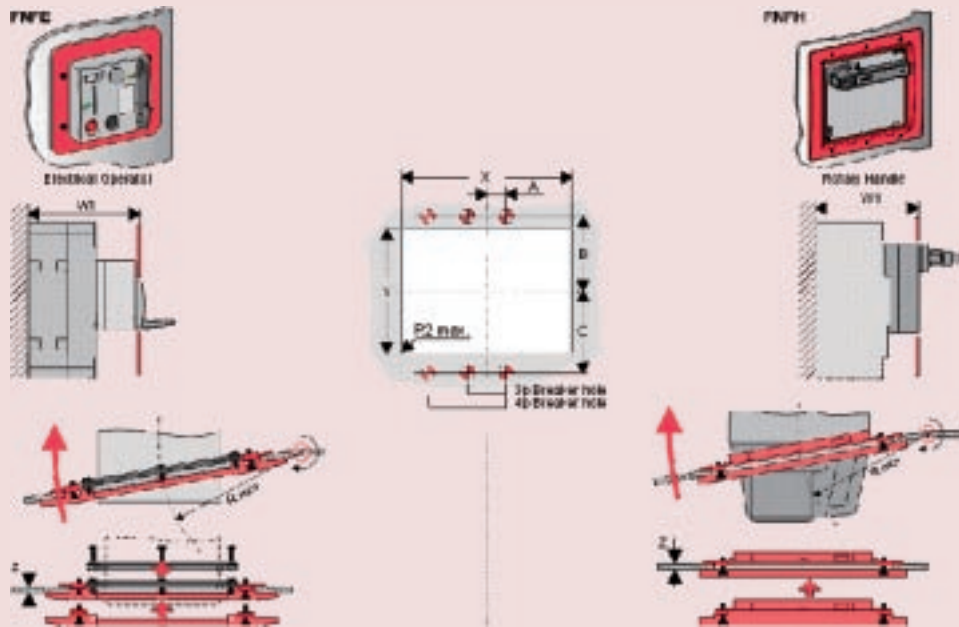

Dimensions										
3 + 4 pole versions			A	B	C	Rmin	W1(max)	X	Y	Z
FNFE	FK 800/1250/1600	Electr. Operator	35	129	151	120	220	142	125	1...4
FNFH	FK 800/1250/1600	Rotary Handle	35	114	163	190	210	232.5	232.5	1...4

# Dimensional Drawings

## Breaker with short terminal shields - FK800/1250/1600

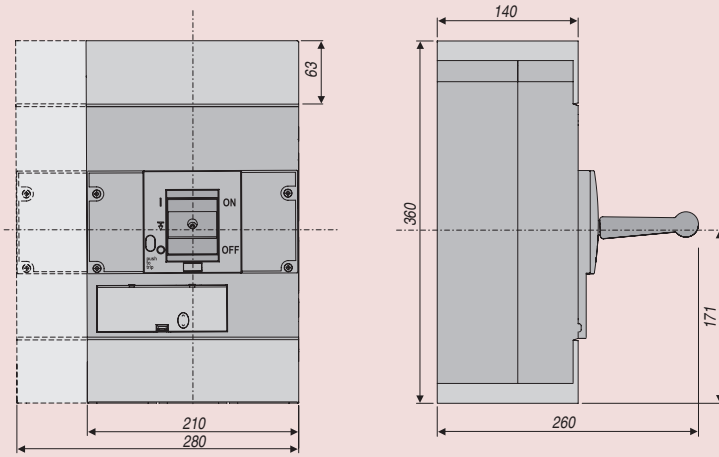

## Breaker with long terminal shields - FK800/1250/1600

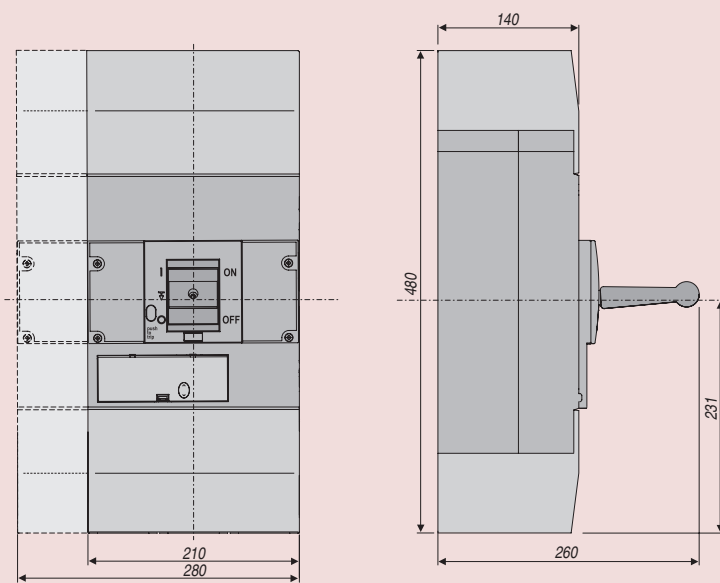

Dimensional Drawings

Connectivity 60 mm system - FD and FE frame 3 pole

Dimensions

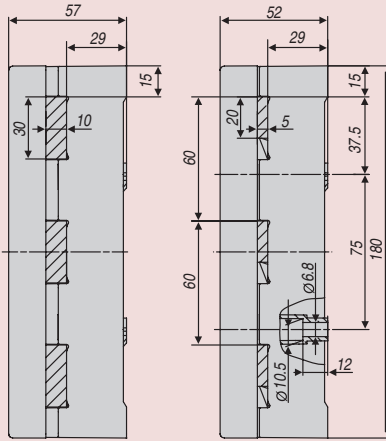

433458  
FBB3S

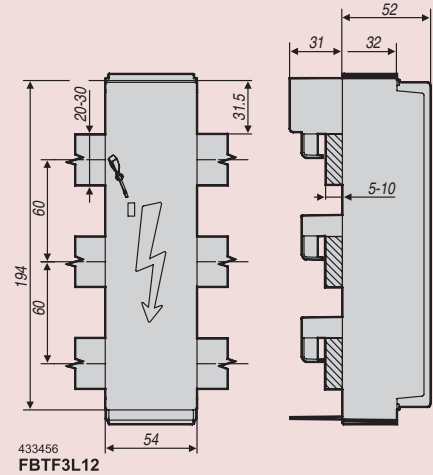
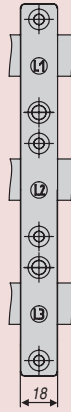

433456  
FBTF3L12

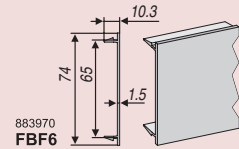

883970  
FBF6

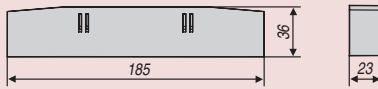

433455  
FBB3E

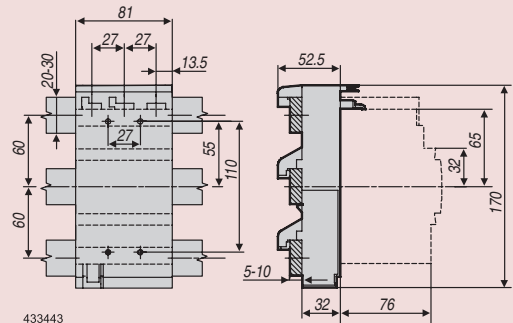

433443  
FBAD3 FD frame 3p

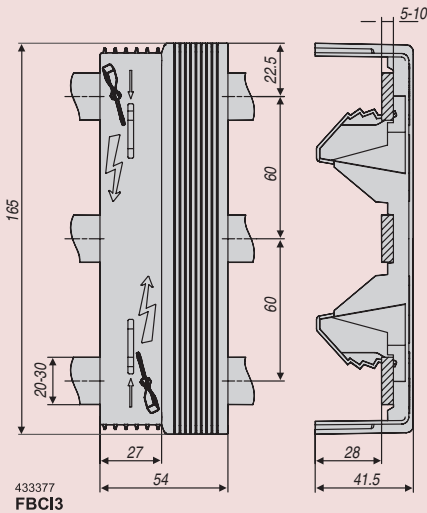

433377  
FBCI3

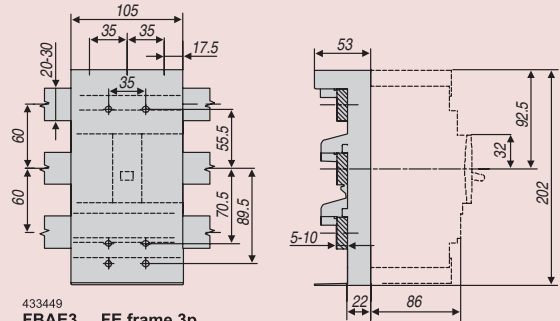

433449  
FBAE3 FE frame 3p

G

# Dimensional Drawings

## Connectivity 60 mm system - FD and FE frame 4 pole

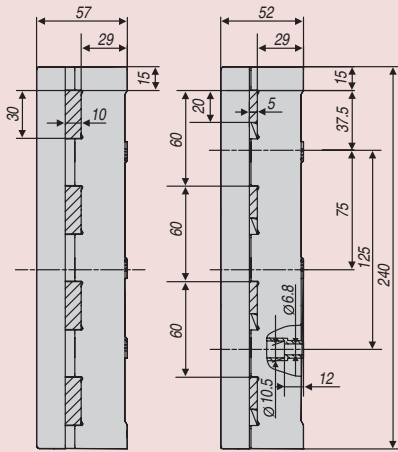

433464  
FBB4S

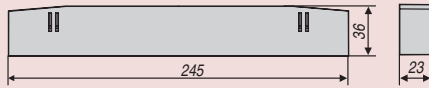

433461  
FBB4E

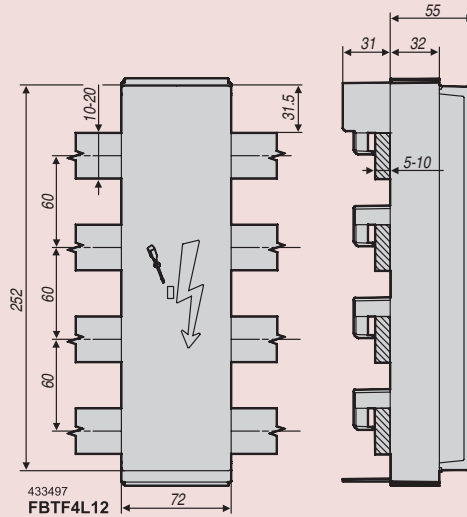

433497  
FBTF4L12

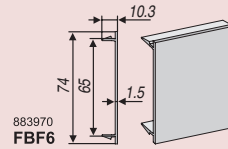

883970  
FBF6

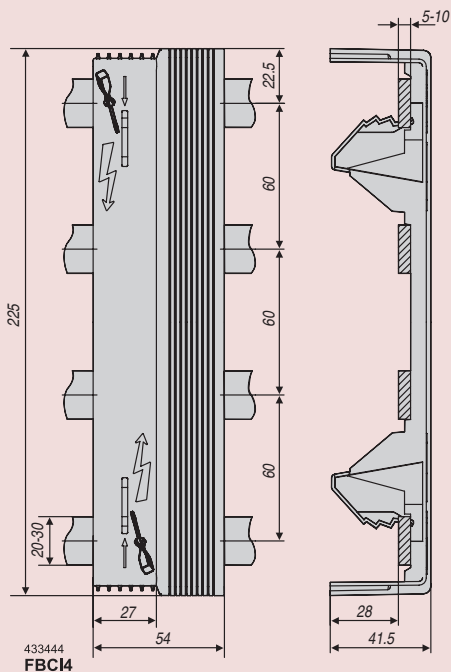

433444  
FBC14

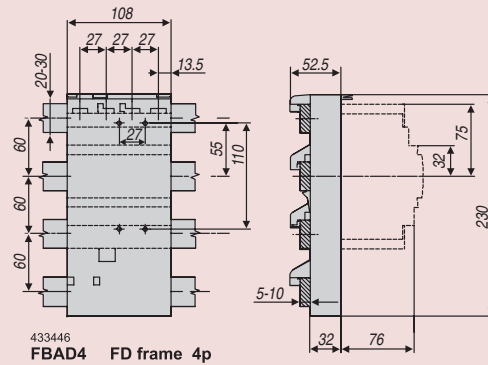

433446  
FBAD4 FD frame 4p

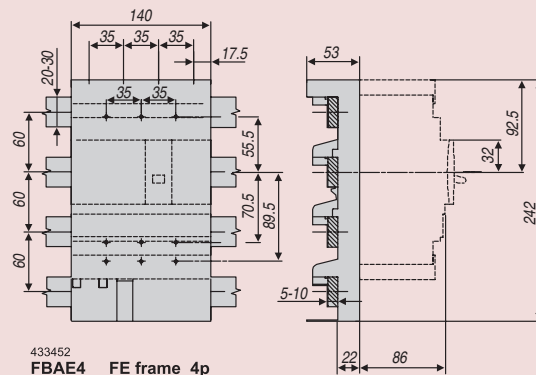

433452  
FBAE4 FE frame 4p

## Dimensional Drawings

### Relay RD5 and RD6

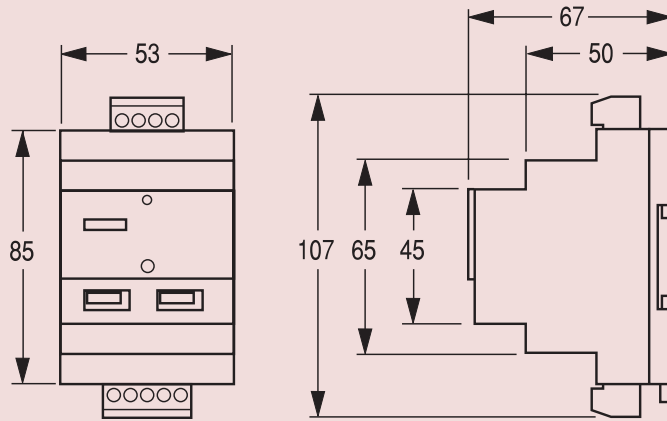

### Circular sensor

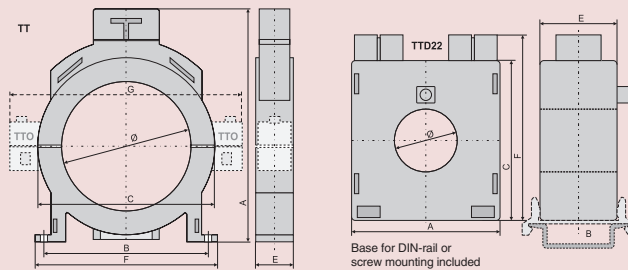

Dimensions							
	Ø	A	B	C	E	F	G
TTD22	22	52	21	56	27	65	
TT35	35	118	90	78,5	27	104	
TT60	60	143	102	94,5	27	117	
TT80	80	163	110	114,5	27	125	
TT110	110	198	140	150,5	32	155	
TT160	160	248	181	200,5	32	197	
TT210	210	298	210	250,5	32	227	
TT0110	110	198	140	150,5	32	155	198
TT0210	210	298	210	250,5	32	227	296

### Rectangular sensor

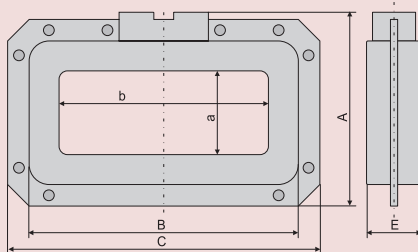

Dimensions						
	a x b	H	h	E	e	d
BTR 175	70x175	162	85	261	46	225
BTR 305	115x305	226	116	402	55	360
BTR 350	150x350	271	140	460	55	415